

Ceiling Radiant Cooling Panels as a Viable Distributed Parallel Sensible Cooling Technology Integrated with Dedicated Outdoor Air Systems

Christopher L. Conroy
Associate Member ASHRAE

Stanley A. Mumma, Ph.D., P.E.
Fellow ASHRAE

ABSTRACT

Emphasis is placed upon the integration of ceiling radiant panel cooling technology with other building mechanical systems in this paper. Applicable radiative and convective heat transfer equations are applied to illustrate the rates of heat removal that are representative of this technology. Also presented are the fundamental heat transfer equations that govern the radiant cooling panel mean temperature as a function of geometry, materials, flow rates, coolant temperature, and space temperatures. These fundamentals are then illustrated by a simple example where the radiant panels are integrated with a dedicated outdoor air system capable of maintaining the space dew-point temperatures. In this context, the radiant panels have no dehumidification duty, and condensation will not form on the surfaces. The illustration covers each of the iterative steps required to select the ceiling radiant cooling panels and a simplistic analysis of the resulting economic benefits. The paper wraps up with a detailed discussion of the functional integration of three hydronic systems: the dedicated outdoor air system cooling coil, the radiant panel network, and fire suppression network. The paper concludes that technical and economic barriers do not currently exist to inhibit the widespread application of ceiling radiant cooling panels with dedicated outdoor air systems. The dedicated outdoor air systems must be designed to control 100% of the space latent loads and, hence, the space dew-point temperatures.

INTRODUCTION

The central thrust of this paper is to bring together the engineering information necessary to wisely and cost-effectively apply ceiling radiant cooling panels (CRCP) as one of

several available sensible cooling technologies suitable for operation in parallel with a dedicated outdoor air system. Once the decision is made to use a dedicated outdoor air (OA) system (Mumma 2001), it is only a small migration step to condition that air sufficiently to meet all of the OA latent as well as all of the space latent loads. A dedicated outdoor air system (DOAS) that efficiently supplies cool dry OA is discussed in detail in a paper by Mumma and Shank (2001). With no latent loads remaining in the space, technologies such as CRCP cooling can be confidently applied without concern for condensation. While CRCP cooling has seen very limited application in the U.S., Europeans have successfully applied it for over fifteen years. Condensation on cooling panel surfaces is not a problem when the panel surface temperature is maintained above the space dew-point temperature.

CRCPs are commercially available in a linear or modular form to fit well into a suspended ceiling grid. The panel's fins are constructed mainly of either aluminum or copper. Copper tubing (serpentine or parallel flow arrangements) is thermally bonded to the fin. The CRCPs are installed with a blanket of insulation back loaded on top to minimize heat transfer with the plenum.

LITERATURE REVIEW

Many papers discuss the theory of radiant cooling and document its comfort, efficiency, and cost-effectiveness. Kulpmann (1993) reported on the fine thermal comfort in a space with a chilled ceiling and ventilation air. Simmonds (1996) demonstrated the comfort levels as defined by the mean radiant temperatures (MRT) in a space that uses radiant heating and cooling. Simmonds (1997) assessed the first and long-term savings of CRCP systems as follows:

Christopher L. Conroy is a mechanical engineer in training at L.D. Astorino Companies, Pittsburgh, Penn. **Stanley A. Mumma** is a professor in the Department of Architectural Engineering, Penn State University, University Park, Penn.

- First cost with experienced contractors is generally 15% less than installing a conventional air system.
- Long-term savings are dramatic, i.e., in the neighborhood of 20-30%, as a result of smaller and more efficient chillers and reduced fan power.
- They promise greatly reduced operation and maintenance costs since there are minimal moving parts and no filters.
- Testing and balancing at commissioning before occupancy is much simpler and less expensive to perform.

Stetiu et al. (1995) report on a mathematical model and computer code to simulate the dynamic performance of a hydronic radiant cooling system. Finally, Brunk (1993) reported on the thermal comfort and energy savings advantages of radiant cooling. The design integration focus of this paper is intended to complement the current archival and trade literature.

RADIANT CEILING PANEL COOLING PERFORMANCE

The industry refers to this technology as radiant panel cooling, but in fact, the cooling occurs by the combined heat transfer mechanisms of radiation and convection. The 1996 *ASHRAE Handbook—HVAC Systems and Equipment* (ASHRAE 1996) provides an overview of radiant panel cooling.

Advantages

All of the sixteen advantages discussed in the general evaluation section (ASHRAE 1996, page 6.1.2) strongly support the application of this technology, but six relate strongly to this paper. They are as follows.

- Comfort levels can be better than those of other conditioning systems because radiant loads are treated directly and air motion in the space is at normal ventilation levels.
- Supply air quantities usually do not exceed those required for *ventilation and dehumidification* (emphasis added by authors).
- A 100% outdoor air system may be installed with smaller penalties, in terms of refrigeration load, because of reduced outdoor air quantities (multiple spaces equation 6.1 of *ANSI/ASHRAE Standard 62-1999* does not apply to this situation).
- Wet surface cooling coils are eliminated from the occupied space, reducing the potential for septic contamination.
- The panel system can use the automatic sprinkler system piping (see NFPA Standard 13, Chapter 3, Section 3.6).

Other CRCP advantages worth noting but not discussed at length above include the following.

- *Compact design.* The compact design is an advantage for either retrofit design or new construction. In existing

buildings, where ceiling heights and plenum space are important issues, the cooling panels can be used to save on plenum space and allow ceiling heights to be raised to an architecturally pleasing level. The vertical plenum space savings are made possible since the ductwork that would normally serve the entire space sensible cooling load with 55°F (13°C) air is not needed. By supplying only the required ventilation air flow rate, often only about 20% of the normal all-air system air flow rates, the ductwork cross-sectional dimensions become much smaller. Problems with duct crossover structural clearances, and other plenum congestion are reduced. Supply and return fan sizes are also significantly reduced, as is the operating energy use.

- *Vertical shaft space area/volume savings.* Vertical distribution conduits (piping and ductwork) are smaller when CRCPs are utilized compared to all-air systems. The large supply and return ductwork, characteristic of all-air systems transporting air vertically through a building with all-air systems, is replaced by much smaller cross-sectional water pipe. Of course, the ductwork for the ventilation air must still be accommodated. This leads to less shaft space, less lost “rentable” space, and very happy architects. In a recently completed retrofit redesign feasibility study (Conroy 1999), CRCPs were used in place of constant volume air-handling units. Using CRCPs eliminated 12 of the 16 air-handling units. As a result, less mechanical room space and more useful floor area were available for use by the building owner.
- *When used in new construction, the CRCPs achieve all of the advantages that a retrofit project achieves,* plus the owner can save money in construction by decreasing the overall height of the building or adding about one floor for every five floors when compared to conventional construction.
- *Quick accommodation of dynamics,* since the panels have a time constant of about three minutes
- *Spaces may be zoned* by the use of a control valve for each zone.

Radiant Heat Transfer

The radiant heat transfer is governed by the Stefan-Boltzmann equation. For most building enclosure cases encountered in practice, the enclosure emittances are about 0.9, and the view factor between the ceiling and the balance of the enclosure is at least 0.87. Placing these common values into the Stefan-Boltzmann equation results in the following equation (ASHRAE 1996):

$$q_r = 0.15 \times 10^{-8} [(t_p)^4 - (\text{AUST})^4], \quad (1)$$

where

q_r = radiant cooling, Btu/h-ft² (W/m²)

t_p = mean panel surface temperature, °R (K)

AUST = area weighted average temperature of the non-

radiant panel surfaces of the room, °R (K).

Normally this means that the air temperature (t_a) is about this temperature as well, particularly in cases where the design conforms to *ANSI/ASHRAE/IESNA Standard 90.1-1999* (ASHRAE 1999a).

An enclosure with an area weighted average temperature of 75°F (24°C), served by a CRCP with a mean surface temperature of 60°F (16°C) (note, the cooling water serving the panel is below this temperature and is discussed in more detail later in this section), will absorb slightly more than 13 Btu/h·ft² (41 W/m²) by radiation.

Convective Heat Transfer

The rate of heat transfer by convection is a combination of natural and forced convection. Natural convection results from the cooled air in the boundary layer just below the panels being displaced by warmer air in the room. This natural process can be altered or even changed to forced convection by infiltration, human activity, and the mechanical ventilation systems. Research suggests (Min 1956) that for practical panel *cooling* applications without forced convection, the cooling convective heat transfer is given by the following equation (ASHRAE 1996):

$$q_c = 0.31(t_p - t_a)^{0.31}(t_p - t_a). \quad (2)$$

An enclosure with an area weighted average temperature (t_a) of 75°F (24°C), served by a CRCP with a mean surface temperature of 60°F (16°C), will absorb slightly less than 11 Btu/h·ft² (35 W/m²) by convection.

Combined Radiant and Convective Heat Transfer

When the two mechanisms are combined, the rate of heat transfer for a space at 75°F (24°C) and a panel temperature of 60°F (16°C) is 24 Btu/h·ft² (76 W/m²). The associated overall heat transfer coefficient (based upon the occupied space radiant panel surface area) is 1.6 Btu/h·ft²·°F (9.1 W/m²·°C). Rates of heat transfer and associated overall heat transfer coefficients for

other room and panel temperatures are presented in Table 1. The *1996 ASHRAE Handbook—Systems and Equipment* (ASHRAE 1996) notes that with forced convection, the total rate of heat transfer by the combined mechanism remains about the same as with natural convection. Table 1 illustrates two points that are discussed. First, the greater the difference between the mean panel temperature and the room temperature, the greater the heat transfer. First, at the two extremes presented in the table, when the temperature difference is only 7°F (4°C)—65°F (18°C) mean plate temperature and 72°F [22°C] room temperature—the rate of heat removal is only 10 Btu/h·ft² (32 W/m²). When the temperature difference is 28°F (16°C)—50°F (10°C) mean plate temperature and 78°F [26°C] room temperature—the rate of heat removal increases to 48 Btu/h·ft² (151 W/m²). Second, even though the radiant heat transfer is highly nonlinear, the overall U-factors are relatively constant in the ranges of temperatures presented in the table. This observation is used next to compute the mean panel temperatures from first principles and geometric data.

Determining the Mean Panel Temperature

Since Equations 1 and 2 are functions of the mean plate temperature and not the inlet fluid temperature, it is important to be able to compute the mean plate temperature. In developing the fundamental basis for computing the mean plate temperature, an analogy to solar collectors is made. CRCPs are constructed very similarly to flat plate solar collector absorbers and behave in a similar fashion. One of the biggest differences is that the rate of heat transfer by radiation is an order of magnitude smaller for the CRCPs than for the solar absorbers. As with solar absorbers, the panel performance is a function of the following variables:

- tube diameter, D
- flow rate per panel, m
- panel/tube length, L

TABLE 1
CRCP Heat Transfer Characteristics

Mean panel temperature °F (°C)	Room temperature/AUST °F (°C)	$q_{radiation}$ Btu/h·ft ² (W/m ²)	$q_{convection}$ Btu/h·ft ² (W/m ²)	q_{total} Btu/h·ft ² (W/m ²)	U , overall HT coeff, Btu/h·ft ² ·°F (W/m ² ·°C)
50 (10)	72 (22)	19 (60)	18 (57)	37 (117)	1.66 (9.43)
55 (13)	72 (22)	15 (47)	13 (41)	28 (88)	1.61 (9.14)
60 (16)	72 (22)	11 (35)	8 (25)	19 (60)	1.54 (8.75)
65 (18)	72 (22)	6 (19)	4 (13)	10 (32)	1.45 (8.23)
50 (10)	78 (26)	24 (76)	24 (76)	48 (151)	1.73 (9.82)
55 (13)	78 (26)	20 (63)	19 (60)	39 (123)	1.7 (9.65)
60 (16)	78 (26)	16 (51)	14 (44)	30 (95)	1.65 (9.37)
65 (18)	78 (26)	12 (38)	9 (28)	21 (66)	1.59 (9.03)

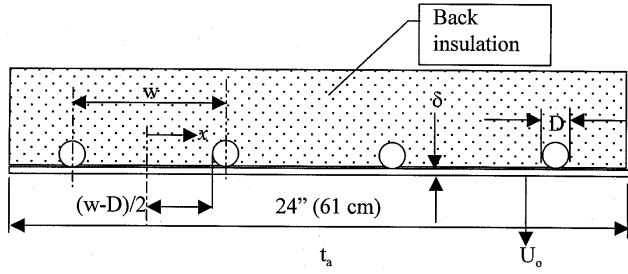

Figure 1 Cross section of a ceiling radiant cooling panel.

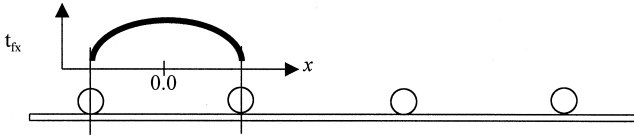

Figure 2 Temperature distribution along the fin between the tubes.

- tube center-to-center spacing, w
- panel area, A
- fin thickness, δ
- fin material, i.e., thermal conductivity, k
- inlet cool fluid temperature, t_{fi}
- room temperature, t_a
- overall heat transfer coefficient, U_o
- piping arrangement, i.e., parallel tube or serpentine

An illustration of a CRCP cross section and the important variables associated with the geometry is shown in Figure 1. The design challenge is to determine the mean plate temperature for a given mass flow rate and geometry. The details are not presented here, only the highlights. The details may be found in Duffie and Beckman (1991). Determining the temperature distribution in the x direction (perpendicular to the tubes, see Figure 1) for parallel headers follows.

$$\mu = (U_o / k\delta)^{0.5} \quad (3)$$

$$F = \{ \tanh [\mu(w - D)/2] \} / [\mu(w - D)/2] \quad (4)$$

$$(t_{f,x} - t_a) / (t_b - t_a) = \cosh(\mu x) / \cosh[\mu(w - D)/2] \quad (5)$$

where F is the fin effectiveness, and t_b is the temperature of the fin at $x = 0$.

When in the cooling mode, the temperature distribution over the fin appears as illustrated in Figure 2. Note that the fin is warmer at the centerline between the tubes than at the base of the fin, which is close to that of cooling fluid flowing in the tube.

Temperature Distribution in the Direction of Flow

The fluid flowing in the parallel tubes increases in temperature exponentially as the panel removes heat from the

cooled space. Performing a mass and energy balance on the tube/fin in the direction of flow yields the following equations (Duffie and Beckmann 1991).

$$F' \simeq [D + (w - D)F] / w \quad (6)$$

$$(t_{f,out} - t_a) / (t_{f,in} - t_a) = \text{Exp}(-UAF' / mC_p) \quad (7)$$

$$F_R = [mC_p(t_{f,out} - t_{f,in})] / \{A[-U(t_{f,in} - t_a)]\} \quad (8)$$

$$T_{p,mean} = t_{f,in} + \{mC_p(t_{f,out} - t_{f,in}) / (AF_R U)\} (1 - F_R) \quad (9)$$

where

F' = the panel efficiency factor (ratio of overall heat transfer coefficient fluid to room to overall heat transfer coefficient fin to room);

$t_{f,out}$ = the radiant panel outlet fluid temperature;

$t_{f,in}$ = the radiant panel inlet fluid temperature;

A = the panel area;

F_R = the panel heat removal factor, which is the ratio of the heat removed to the heat removed if the entire panel were at the inlet fluid temperature;

$T_{p,mean}$ = the mean radiant panel temperature;

m = the mass flow rate to the panel.

Note: with a serpentine arrangement, the $t_{f,out}$ is slightly lower for the same $T_{p,mean}$ (i.e., less cooling). Employing these equations permits the engineer to investigate the trade-offs associated with varying the room dew-point temperature (the desired room dew-point temperature along with the latent load in the space defines the required supply air dew-point temperature). The lower the room dew-point temperature, the lower the supply water ($t_{f,in}$) can be, and, for a given panel design, the lower the mean plate temperature and the higher the heat removal rate. The actual design of the panel is also something that can be investigated, as well as the mass flow rate of fluid to the panel. Applying Equations 3-9 to the following situation, the mean plate temperature is found to be 60°F (16°C).

- $w = 6$ in. (15 cm)
- $D = 0.5$ in. (1 cm)
- $A = 64$ ft² (6 m²), 2 ft × 32 ft (0.6 m × 10 m)
- number of tubes, 4
- fin thickness, $\delta = 0.125$ in. (3 mm)
- fin material, aluminum, $k = 119$ Btu/h·ft·°F (206 W/m²·°C)
- mass flow rate, $m = 300$ lb_m/h (0.04 kg/s)
- $t_{f,in} = 55$ °F (13°C)

The resulting fin efficiency factor F is 0.98, F' is 0.97, F_R is 0.83, and $t_{f,out}$ is 60°F (16°C).

Ceiling Radiant Panel Cooling Analysis Summary

The engineer has many variables to establish in the process of coming to a working final design. The CRCP variables have been explored in this section. The next section addresses placing these variables into a larger context.

TABLE 2
Information Pertinent to the CRCP Cooling Selection

Column 1	2	3	4	5	6	7
Room design DBT °F (°C)	Room design % RH	Room design DPT °F (°C)	DOAS supply DPT with 20 scfm/person °F (°C)	Panel t_{fi} room DPT+3°F °F (°C)	Mean panel temp. assuming $t_{fi}+5°F$ °F (°C)	Q_s , Btu/h·ft ² (W/m ²)
72 (22)	40	46 (8)	37 (3)	49 (9)	54 (12)	30 (95)
72 (22)	60	57 (14)	51 (11)	60 (16)	65 (18)	10 (32)
78 (26)	40	52 (11)	44 (7)	55 (13)	60 (16)	30 (95)
78 (26)	60	63 (17)	58 (14)	66 (19)	71 (22)	10 (32)

Iterative Ceiling Radiant Panel Cooling Selection Procedure

The starting point (step 1) in this process is defining the design space conditions. Standard 90.1-1999 (ASHRAE 1999a) defines the summer and winter space design conditions as 78°F (26°C) and 72°F (22°C), respectively. Sterling et al. (1985) strongly recommend that the space RH be maintained between 40% and 60%. Table 2 presents the associated space dew-point temperature (DPT) for these four conditions with other information. As may be seen, room dew-point temperatures fall between 46°F (8°C) and 63°F (17°C), depending on the season and the upper and lower bounds of RH.

Step 2 in the selection process is to estimate the rate of heat removal range that a CRCP system could be expected to perform. Presented in column 4 of Table 2 is the required supply air DPT from the DOAS unit necessary to meet the complete space latent load with 20 scfm (9 L/s) of OA per person. It assumes that the building is pressurized (or no latent load from infiltration) and that the entire latent load is from the occupants at 205 Btu/h/person (60 W/person). Column 5 is the first iteration panel inlet temperature, set 3°F (2°C) greater than the space DPT. Column 6 is the first iteration mean panel temperature (based upon experience), which is 5°F (3°C) greater than the inlet water temperature. Finally, in column 7, the combined rates of heat transfer by convection and radiation based upon Equations 1 and 2 are presented. Within the range of space conditions and other performance assumptions, it is observed that the rates of heat extraction range from 10 to 30 Btu/h·ft² (32-95 W/m²). For reference, a good solar collector on a clear day is able to collect over 200 Btu/h·ft² (631 W/m²).

Step 3 in the selection process is a determination of the sensible cooling that the CRCP needs to serve. To illustrate this step, consider a 1000 ft² (93 m²) open office area with an occupancy of seven (ASHRAE 1999b) and a combined illumination/equipment load of 3 W/ft² (32 W/m²). Further, assume that, at design, the exposed envelope contributes a sensible load of 4000 Btu/h (1172 W). The combined sensible cooling load for the space is about 14,000 Btu/h (4103 W). At 20 scfm (9 L/s) per person, the 140 scfm (66 L/s) of ventilation air, if supplied at 55°F (13°C) to a room maintained at 78°F

(26°C), would provide about 3500 Btu/h (1026 W), or about 33% of the internal generation sensible load. The CRCP system must then meet the difference between the space sensible load and the portion met with the DOAS unit, or about 10,500 Btu/h (3077 W).

Step 4 is to select the CRCP size within the heat flux capabilities and the ceiling area available. In this example, it is clear that, at a heat removal rate between 30 Btu/h·ft² (95 W/m²) and 10 Btu/h·ft² (32 W/m²), between 350 ft² (33 m²) and 1050 ft² (98 m²) of CRCP is required. If the ventilation air had been supplied at a neutral temperature, thus unable to provide any sensible cooling, then even at 30 Btu/h·ft² (95 W/m²) almost 500 ft² (46 m²) of CRCP would have been required.

Obviously, at 1050 ft² (98 m²), there is not enough ceiling. Figure 3 illustrates a potential layout of the 1008 ft² (94 m²), 28 ft × 36 ft (9 m × 11 m), open office plan ceiling that contains 126 2 ft × 4 ft (0.6 m × 1 m) drop ceiling tile. Superimposed on the drop ceiling are seven rows of CRCP, or 392 ft² (36 m²). With 392 ft² (36 m²), the required panel sensible heat removal rate is only 27 Btu/h·ft² (85 W/m²). Therefore,



Figure 3 Possible ceiling radiant cooling panel layout in a 1008 ft² (94 m²) open office plan example.

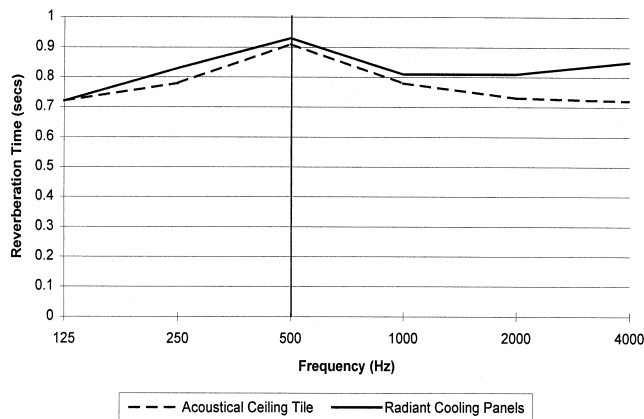

Figure 4 Graphical comparison of the acoustical performance of perforated ceiling radiant cooling panels and acoustical ceiling tile.

the mean plate temperature can rise to 62°F (17°C). This can be accompanied with an equivalent increase in the inlet fluid temperature and the space DPT. To be sure that the selection is product specific, manufacturers' literature and performance nomograms must be consulted. Further iterations concerning design temperatures and layout are to be expected. Even without further refinement, it is possible to make a preliminary estimate of the relative costs of the CRCP and an equivalent VAV system. The installed cost of the CRCP is about \$8/ft² (\$86/m²). A VAV system capable of handling the same 10,500 Btu/h (3077 W) sensible load would take 425 scfm (200 L/s) of air at 55°F (13°C). A VAV air-handling unit costs about \$2/scfm (\$4/(L/s)), the VAV boxes about \$6/scfm (\$13/(L/s)), and the associated ductwork about \$4/scfm (\$8/(L/s)) (Means 2000). The resulting simple cost comparison shows about \$3000 for the CRCP and \$5000 for the equivalent VAV system. In addition to the favorable first cost comparison, the significant cost of operating the fans in the VAV system compared to the low pumping costs associated with the CRCP system makes the VAV approach even less attractive. These conclusions are consistent with those of Simmonds (1997). Even though the first cost of the CRCP system is less than an equivalent all-air VAV system, there are great opportunities to see the cost of the panels drop into the \$1-\$3/ft² (\$11-\$32/m²) range—a cost typical of solar absorber panels. Opportunities also abound for reducing the installed piping costs by developing automated CRCP site-manufacturing capabilities, so the panel length can be custom adapted to one of the major dimensions of the space. For example, one 32 ft (10 m) long panel has at least 16 less piping connections to make than eight 4 ft (1 m) long panels filling the same area. With a parallel header arrangement, the panels could be even much longer since the heat flux is relatively low.

Step 5 is to evaluate the acoustical behavior of the CRCP selection. Commercially available CRCPs can be purchased

with perforations in the surface to allow acoustical energy to travel through the panel's fins and be absorbed by the back loaded insulation above. The fin perforation design can be varied dependent upon the acoustical performance needed in the space. If high absorption is needed, the perforated panel fins provide almost the same performance as acoustical ceiling tile. In contrast, if a high reflectance is needed, then the panels can be nonperforated to reflect the sound. Based on manufacturers' sound data on a perforated CRCP, a reverberation time analysis was performed to compare the difference of a perforated CRCP and an acoustical ceiling tile. The results of this analysis are shown in Figure 4. The graph shows how the CRCP compares to an acoustical ceiling tile for a 66,000 ft³ (1869 m³) lecture hall. Reverberation time measures the echoic nature of the space. The results show that the reverberation times follow along slightly higher than the acoustical ceiling tile until the upper octave frequency bands. Upper frequency band deviation is not significant since the human ear becomes less discerning at frequencies greater than 500 Hz. At the 500 Hz octave band, the reverberation times for both the perforated CRCP and the acoustical ceiling tile are close to 0.90 second. The results of the reverberation time analysis show that the addition of CRCP in a space does not dramatically alter the acoustical quality of spaces.

Step 6 involves the selection of high aspiration diffusers for the DOAS ventilation air. High aspiration diffusers greatly improve room air circulation. This type of diffuser, originally designed for cold air systems, is capable of increasing the air circulation in the space to the point where the air diffusion performance index (ADPI) is greater than 90%.

HYDRONIC INTEGRATION

Utilization of a DOAS to control the space DPT permits the use of uninsulated sprinkler piping to serve the CRCP (Janus 2001) without fear of condensation problems. The functional integration also has a measurable economic benefit. The hydronic integration is illustrated in Figure 5.

Pipe Insulation

The chiller/DOAS chilled water loop must be insulated since the temperature is well below the controlled DPT. The piping from the chiller loop past valve V2 and to the inlet to pump P2 must also be insulated. All other piping in Figure 5 need not be insulated, which is the bulk of the system. It includes the piping that serves the dual purpose of thermal/fire suppression transport system.

Chilled Water Loop Control

A constant volume pump P1 serves the chiller, which is to maintain a 40°F chilled water (CHW) supply temperature. Constant flow is maintained by use of a three-way mixing valve at the DOAS coil.

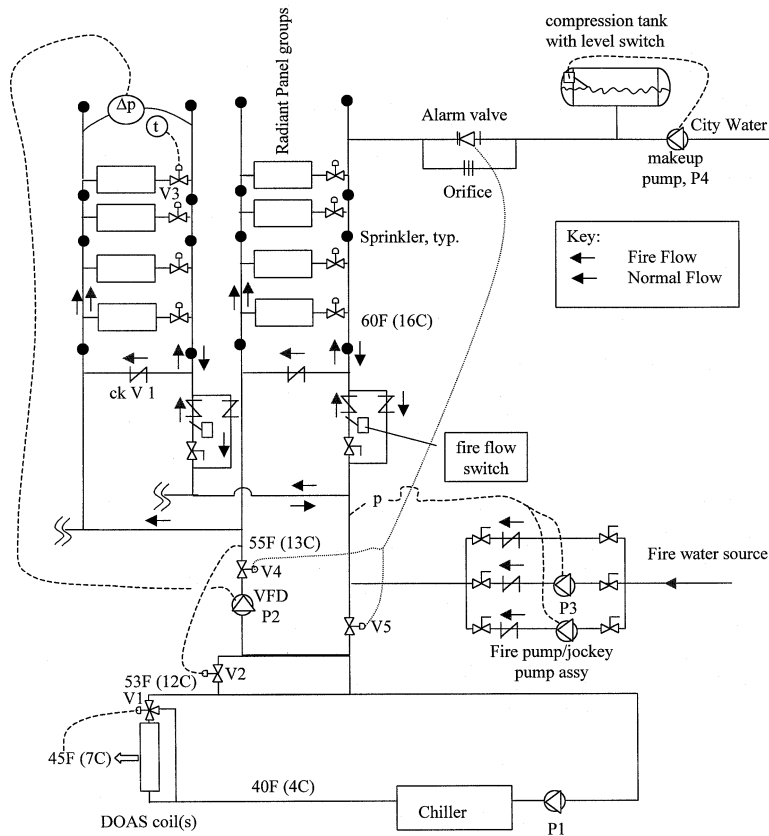

Figure 5 Functional integration of the chilled water piping, the radiant cooling panel network, and the fire suppression network.

Ceiling Radiant Panel Cooling Loop Control

The supply water temperature to the entire array of CRCP (independent of floors) is controlled by the two-way valve V2 in response to the measured supply water temperature. The valve permits water from the chilled water loop after the DOAS coils to be drawn into the CRCP distribution system by pump P2. The rate of water delivered by pump P2 is modulated to maintain a constant differential pressure at the distant CRCP sufficient to meet design flow. The flow of water through a CRCP array is modulated by control valve V3 (typical at each temperature controlled space) in response to the space thermostat. To avoid condensation at start-up or extreme off-design conditions, one of two approaches may be taken. The pump P2 can be interlocked with the space DPT and allowed to operate only when humidity control has been achieved. An alternative may be to adjust the set point in the control valve V2 loop in response to the measured dew-point temperature, always maintaining the set point a few degrees above the measured DPT. In the latter case, pump P2 could start when the other equipment is activated.

Fire Suppression System Control

The non-fire-suppression mode is presented first. An integral part of the fire suppression system is the automatic fill

system illustrated at the top of Figure 5. Pump P4 is sized to deliver about half the rate of water that a sprinkler head delivers. Pump P4 is controlled to maintain a fixed water level in the compression tank illustrated. That rate of flow can be accommodated via the orifice without triggering the alarm valve. A second major part of the fire suppression control system is the fire pump/jockey pump assembly. Under normal operating conditions, the fire water source maintains the hydronic system pressure. The arrows on the panel supply and return piping (which also serves the sprinkler heads) indicate the normal direction of flow. On each floor, there are two other assemblies. One assembly contains a fire flow switch, two check valves, and a manual shutoff valve. The normal HVAC flow direction through the right side check valve is illustrated. The other assembly is the connecting piping between the HVAC supply and return piping, which contains check valve CK V1.

The fire suppression mode is presented next. When a sprinkler head opens, the following sequence of events occurs.

- The compression tank attempts to feed the head(s).
- The large flow triggers the alarm valve.
- A signal is sent to stop HVAC pumps P1 and P2 and the chiller and to close the normally open isolation valves V4 and V5.

- As the system pressure drops, the fire pumps P3 are activated, and flow in the HVAC return piping is reversed, feeding the open sprinkler head(s).
- On the floors where the sprinkler heads are open, flow is sensed by the fire flow switch(es), helping to pinpoint where the fire is.
- The HVAC supply piping is also now fed from the fire water source by way of check valve CK V1 (typical on each floor).
- Fire water does not need to flow through any of the CRCPs to reach the sprinkler head(s).

CONCLUSIONS AND RECOMMENDATIONS

The fundamental heat transfer associated with CRCPs has been presented and illustrated with a simple example. When applied with DOAS equipment capable of controlling the space DPT and interlocks employed to prevent operation of the CRCP system during unfavorable space DPTs, CRCPs can be applied without condensation concerns. In addition, the size and first cost of the CRCP array is strongly influenced by the maintained space DPT (and, hence, the permissible panel inlet fluid temperature) and the supply air temperature from the DOAS unit. The lower the SAT, the less sensible cooling duty falls to the CRCP. In the illustration it was shown that the CRCP first cost is less than the VAV boxes and air-handling units necessary to satisfy the same sensible load. Finally, the integration of the CRCP thermal transport system and the fire suppression piping is illustrated. In conclusion, the technical and cost benefits are present today for the successful cost-effective application of the CRCP with DOAS equipment. Apparently, more successful applications are needed to bring confidence to engineers and potential users.

Future work needs to explore integrating the solar industry into the building CRCP marketplace because of their experience with the technology and the ability to mass produce the panels at very low cost. The work needs to focus on the thermal, aesthetic, and acoustical qualities at low cost. A way to produce the CRCP on site at custom lengths, a concept similar to on-site forming of seamless spouting, warrants further work to reduce the number of field piping connections and their associated cost and leak potential.

REFERENCES

ASHRAE. 1996. *1996 ASHRAE Handbook—HVAC systems and equipment*. Atlanta: American Society of Heating, Refrigerating and Air-Conditioning Engineers, Inc.

ASHRAE. 1999a. *ANSI/ASHRAE/IESNA Standard 90.1-1999, Energy standard for buildings except low-rise res-*

idential buildings. Atlanta: American Society of Heating, Refrigerating and Air-Conditioning Engineers, Inc.

ASHRAE. 1999b. *ANSI/ASHRAE Standard 62-1999, Ventilation for acceptable indoor air quality*. Atlanta: American Society of Heating, Refrigerating and Air-Conditioning Engineers, Inc.

Brunk, M.F. 1993. Cooling ceilings—An opportunity to reduce energy costs by way of radiant cooling. *ASHRAE Transactions* 99(2): 479-487.

Conroy, C.L. 1999. Fifth year thesis, Masonic Temple renovation redesign. Penn State University, Department of Architectural Engineering, May.

Duffie, J.A., and W.A. Beckman. 1991. *Solar engineering of thermal processes*, 2d ed. New York: Wiley Interscience.

Janus, W. 2001. Integration of hydronic thermal transport systems with fire suppression systems. *ASHRAE Transactions* 107(1).

Kulpmann, R.W. 1993. Thermal comfort and air quality in rooms with cooled ceilings—Results of scientific investigations. *ASHRAE Transactions* 99(2): 488-502.

Means. 2000. *Mechanical cost estimating guide*.

Min, T.C., L.F. Schutrum, G.V. Parmelee, and J.D. Vouris. 1956. Natural convection and radiation in a panel heated room. *ASHAE Transactions* 62: 237.

Mumma, S.A. 2001. Overview of integrating dedicated outdoor air systems with parallel terminal systems. *ASHRAE Transactions* 107(1).

Mumma, S.A., and K. Shank. 2001. Achieving dry outside air in an energy-efficient manner. *ASHRAE Transactions* 107(1).

NFPA 13. 1999. *Standard for the installation of sprinkler systems, 1999 edition*. Quincy, Mass.: National Fire Protection Association.

Simmonds, P. 1996. Practical applications of radiant heating and cooling to maintain comfort conditions. *ASHRAE Transactions* 102(1): 659-666.

Simmonds, P. 1997. Radiant systems offer users greater comfort control. *Energy Users News*, vol. 34, March, pp. 34-35.

Stetiu, C., H.E. Feustel, and F.C. Winkelmann. 1995. Development of a model to simulate the performance of hydronic radiant cooling ceiling. *ASHRAE Transactions* 101(2): 730-743.

Sterling, D.M., A. Arundel, and T.D. Sterling. 1985. Criteria for human exposure to humidity in occupied buildings. *ASHRAE Transactions* 91(1B): 611-622.