

**Energy Consumption Characteristics of
Commercial Building HVAC Systems
Volume III: Energy Savings Potential**

Prepared by

Kurt W. Roth
Detlef Westphalen
John Dieckmann
Sephir D. Hamilton
William Goetzler

TIAX LLC
20 Acorn Park
Cambridge, MA 02140-2390

TIAX Reference No. 68370-00

For

Building Technologies Program
Project Manager: Dr. James Brodrick (DOE)
Contract No.: DE-AC01-96CE23798

July, 2002

Following are 4 graphics copied from this report and placed here for convenience. They illustrate the superiority of the “DOAS-Radiant” Approach.

Table 4-1: Energy Savings Potential Summary for 15 Options

Technology Option	Technology Status	Technical Energy Savings Potential (quads)
Adaptive/Fuzzy Logic Controls	New	0.23
Dedicated Outdoor Air Systems	Current	0.45
Displacement Ventilation	Current	0.20
Electronically Commutated Permanent Magnet Motors	Current	0.15
Enthalpy/Energy Recovery Heat Exchangers for Ventilation	Current	0.55
Heat Pumps for Cold Climates (Zero-Degree Heat Pump)	Advanced	0.1
Improved Duct Sealing	Current/New	0.23
Liquid Desiccant Air Conditioners	Advanced	0.2 / 0.06 ¹²
Microenvironments / Occupancy-Based Control	Current	0.07
Microchannel Heat Exchanger	New	0.11
Novel Cool Storage	Current	0.2 / 0.03 ¹³
Radiant Ceiling Cooling / Chilled Beam	Current	0.6
Smaller Centrifugal Compressors	Advanced	0.15
System/Component Diagnostics	New	0.45
Variable Refrigerant Volume/Flow	Current	0.3

Energy Savings of the 15 technologies: 3.99 Quads

Note: the DOAS-Radiant Approach integrates the following items and associated energy savings:

DOAS, Dedicated Outdoor Air Systems	0.45 Quads
Enthalpy Energy Recovery	0.55 Quads
Radiant Ceiling cooling	0.60 Quads
System Component Diagnostics	0.45 Quads
DOAS-Radiant SUBTOTAL	2.05 Quads

Conclusion: DOAS-Radiant can deliver 2.05/3.99 or 51%
If superposition were to apply.

Table 4-6: Summary of Dedicated Outdoor Air Systems Characteristics

Characteristic	Result	Comments
Technical Maturity	Current	
Systems Impacted by Technology	All HVAC equipment	Heating, cooling, and ventilation systems
Readily Retrofit into Existing Equipment/Buildings?	Depends	A DOAS needs many more duct connections
Relevant Primary Energy Consumption (quads)	4.0 quads	All non-individual cooling and ventilation systems; OA heating energy
Technical Energy Savings Potential (quads)	0.4 to 0.5 quads	<ul style="list-style-type: none"> • 10% reduction in heating • 17% reduction in cooling • Approximately no net impact on ventilation energy
Approximate Simple Payback Period	Potentially immediate	Potentially lower first cost (in new construction and major renovation); includes benefit of additional rentable space
Non-Energy Benefits	Improved humidity control and occupant comfort	By delivering more appropriate space conditioning to different zones, zonal control decreases temperature swings, improving occupant comfort and possibly increasing productivity. In applications with small indoor humidity loads and low infiltration, a DOAS allows de-coupling of the latent and sensible load management by managing the OA (primary) humidity source separately.
Notable Developers/Manufacturers of Technology	Several	Penn State University, EPRI, McClure Engineering
Peak Demand Reduction	Yes	Yes, by ensuring only that occupied areas receive space conditioning during peak demand periods; a DOAS further reduces peak demand by decreasing OA cooling loads, which approach maximum values during peak demand periods.
Most Promising Applications	Buildings with large amounts of variably occupied space, such as office buildings, hospitals or schools. DOAS systems provide larger benefits in regions where the OA conditioning burden is larger.	
Technology "Next Steps"	Demonstration of energy saving and superior humidity control, design software.	

Table 4-37: Summary of Radiant Ceiling Cooling Characteristics

Characteristic	Result	Comments
Technical Maturity	Current	Much more common in Europe than in the U.S.
Systems Impacted by Technology	All HVAC systems	
Readily Retrofit into Existing Equipment/Buildings?	No	Requires installation of large ceiling panels and piping throughout building.
Relevant Primary Energy Consumption (quads)	3.4 Quads	All non-individual cooling and ventilation energy, heating energy tied to OA
Technical Energy Savings Potential (quads)	0.6 Quads ⁶⁴	<ul style="list-style-type: none"> • 17% cooling energy reduction • 10% heating energy reduction (all from DOAS) • 25% ventilation energy reduction
Approximate Simple Payback Period	Potentially immediate	In new construction or major renovation
Non-Energy Benefits	Improved occupant comfort, low noise, low maintenance	Radiant heating/cooling generally considered more comfortable than forced-air methods. Low maintenance (assuming humidity issue properly managed). Less noise from air distribution. According to Stetiu (1997), radiant cooling reduces ventilation, which reduces space needed for ducts by up to 75%. Zoning readily implemented.
Notable Developers/Manufacturers of Technology	Frenger (Germany). Trox (Germany). Dadanco (Australia; Active Chilled Beams; uses smaller fans to distribute primary air through unit, in combination with secondary, room air)	
Peak Demand Reduction	Yes	Decreases the peak ventilation load required to deliver peak cooling. Stetiu (1997) found 27% demand reduction on average (throughout U.S.).
Most Promising Applications	Tight buildings with high sensible cooling loads, located in low-humidity cooling climates (e.g., hospitals due to one-pass ventilation requirement). Not buildings with appreciable internal moisture loads (e.g., health/fitness clubs, pools).	
Technology "Next Steps"	HVAC system designer/installer education with approach; integration into commonly-used HVAC design tools; demonstration of operational benefits. Cost comparison with VAV system using an enthalpy wheel and dedicated outdoor air systems. Energy savings of chilled beam versus VAV.	

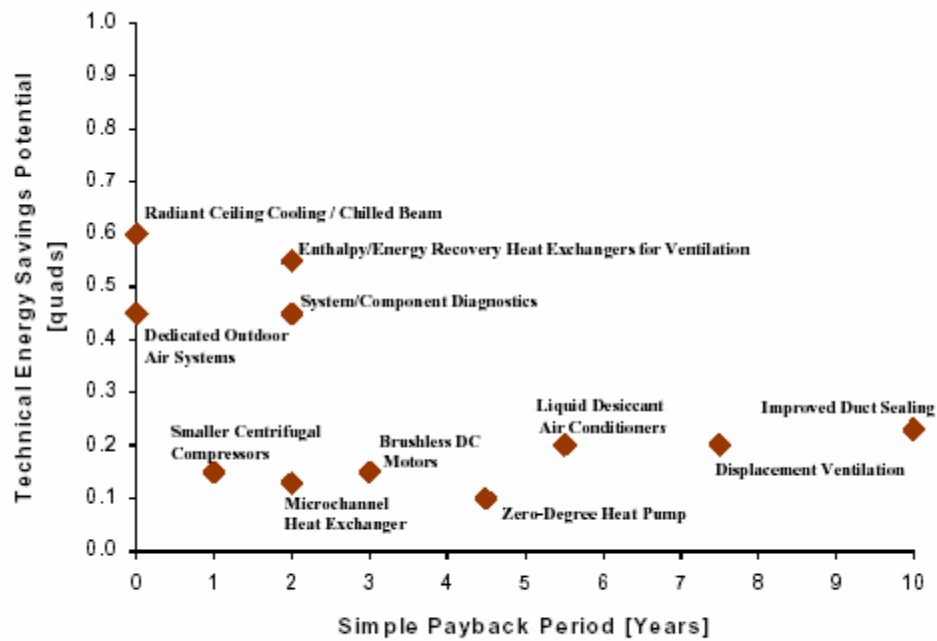

Figure 5-2: Estimated Technical Energy Savings Potential and Simple Payback Periods for the 15 Options

Note: DOAS and Radiant Cooling have instant payback periods

Disclaimer

This report was prepared as an account of work sponsored by an agency of the United States Government. None of the following entities makes any warranty, expressed or implied, or assumes any legal liability or responsibility for the accuracy, completeness, or usefulness of any information, apparatus, product, or process disclosed, or represents that its use would not infringe privately owned rights: a) the United States Government, b) any agency, contractor, or subcontractor thereof, and c) any of their respective employees. Any use the reader makes of this report, or any reliance upon or decisions to be made based upon this report, are the responsibility of the reader. The reader understands that no assurances can be made that all relevant factors have been identified. Reference herein to any specific commercial product, process, or service by trade name, trademark, manufacturer, or otherwise, does not necessarily constitute or imply its endorsement, recommendation, or favoring by the United States government or any agency, contractor or subcontractor thereof. The views and opinions of the authors expressed herein do not necessarily state or reflect those of the United States Government or any agency thereof.

Available to the public from:

National Technical Information Service (NTIS)
U.S. Department of Commerce
Springfield, VA 22161
(703) 487-4650
NTIS Number: PB2002-107657

Acknowledgements

The authors would like to acknowledge the valuable support provided by several others in the preparation of this report. Jennifer Thurber (formerly of ADL) made several contributions in the earlier portions of this effort, particularly in the search for information about and analysis of the 55 technology options, and Donna Bryan (TIAX) helped with the preparation of the final report. Dr. James Brodrick of U.S. Department of Energy provided day-to-day oversight of this assignment, helping to shape the approach, execution, and documentation. He also reviewed and constructively critiqued multiple draft versions of the report. Bryan Berringer, Dru Crawley, Esher Kweller, Cyrus Nasserri, John Ryan, and John Talbott of the U.S. Department of Energy also provided useful feedback on the project.

The report also benefited from the experiences and future vision of a handful of volunteers that provided guidance in the selection of the technology options:

- J. Brodrick (DOE)
- L. Burgett (Trane)
- K. Hickman (York)
- G. Hourahan (ARI)
- B. Hunn (ASHRAE)
- S. Nadel (ACEEE)
- C. Nasserri (DOE)

Finally, literally dozens of contacts in the HVAC industry contributed valuable information and insights about almost all of the 55 technology options selected for further study, greatly enhancing the quality and depth of the report. Individuals from the following companies and organization graciously shared information used in this report; the authors apologize for any omitted from this list.

- Aeroseal, Inc.
- AIL Research, Inc.
- AirXpert Systems, Inc.
- American Superconductor
- Bristol Compressors
- California Economizer
- Copper Development Association
- Cryogel
- Daikin Industries, Ltd.
- Davis Energy Group
- Dedanco
- Energy Planning, Inc.
- Energy Storage Technologies
- EnLink Corporation
- EnLink Geoenery Services, Inc.
- Florida Power & Light Company
- Global Energy and Environmental Research
- Goettl Air Conditioning
- Honeywell
- Johnson Controls, Inc.
- Johnstone Supply

- Lawrence Berkeley National Laboratory
- Lloyd Hamilton, Consultant
- Loren Cook Company
- Los Alamos National Laboratory
- McQuay International
- Modine
- New Buildings Institute
- Paul Mueller Company
- RNGTech.
- Sporlan Valve Company
- Sunpower Corporation
- Taitem Engineering
- Telaire, Inc.
- The Trane Company
- United Technologies
- Water Furnace International, Inc.
- Xetex, Inc.

TABLE OF CONTENTS

1	EXECUTIVE SUMMARY	1-1
1.1	Study Objectives	1-1
1.2	Summary of Findings.....	1-2
2	INTRODUCTION.....	2-1
2.1	Background.....	2-1
2.2	Study Approach	2-6
2.3	Report Organization.....	2-7
3	ENERGY SAVING TECHNOLOGY SELECTION PROCESS.....	3-1
3.1	Initial List of Technology Options (Steps 1 and 2)	3-1
3.2	Selecting 55 Options for Further Study (Step 3)	3-2
3.3	Further Study of the 55 Options (Step 4)	3-3
3.4	Selection of the 15 Options for More Refined Evaluation (Step 5)	3-4
3.5	More Refined Evaluation of 15 Options (Step 6).....	3-4
4	THE 15 TECHNOLOGY OPTIONS SELECTED FOR MORE REFINED STUDY.....	4-1
4.1	Adaptive and Fuzzy Logic Control	4-3
4.1.1	Summary	4-3
4.1.2	Background	4-4
4.1.3	Performance	4-6
4.1.4	Cost	4-6
4.1.5	Perceived Barriers to Market Adoption of Technology	4-7
4.1.6	Technology Development “Next Steps”	4-7
4.1.7	References	4-7
4.2	Dedicated Outdoor Air Systems (DOAS)	4-7
4.2.1	Summary	4-7
4.2.2	Background	4-8
4.2.3	Performance	4-11
4.2.4	Cost	4-12
4.2.5	Perceived Barriers to Market Adoption of Technology	4-13
4.2.6	Technology Development “Next Steps”	4-13
4.2.7	References	4-13
4.3	Displacement Ventilation.....	4-14
4.3.1	Summary	4-14
4.3.2	Background	4-15
4.3.3	Performance	4-18
4.3.4	Cost	4-21
4.3.5	Perceived Barriers to Market Adoption of Technology	4-22
4.3.6	Technology “Next Steps”	4-22
4.3.7	References	4-23
4.4	Electronically-Commutated Permanent Magnet Motors	4-24
4.4.1	Summary	4-24

4.4.2	Background	4-25
4.4.3	Performance	4-25
4.4.4	Cost	4-27
4.4.5	Perceived Barriers to Market Adoption of Technology	4-29
4.4.6	Technology “Next Steps”	4-29
4.4.7	References	4-29
4.5	Enthalpy/Energy Recovery Heat Exchangers for Ventilation	4-29
4.5.1	Summary	4-29
4.5.2	Background	4-30
4.5.3	Performance	4-33
4.5.4	Cost	4-34
4.5.5	Perceived Barriers to Market Adoption of Technology	4-34
4.5.6	Technology “Next Steps”	4-35
4.5.7	References	4-35
4.6	Heat Pumps for Cold Climates (“Zero-Degree” Heat Pumps).....	4-35
4.6.1	Summary	4-35
4.6.2	Background	4-36
4.6.3	Performance	4-38
4.6.4	Cost	4-40
4.6.5	Perceived Barriers to Market Adoption of Technology	4-41
4.6.6	Technology “Next Steps”	4-41
4.6.7	References	4-41
4.7	Improved Duct Sealing	4-42
4.7.1	Summary	4-42
4.7.2	Background	4-43
4.7.3	Performance	4-43
4.7.4	Cost	4-44
4.7.5	Perceived Barriers to Market Adoption of Technology	4-44
4.7.6	Technology “Next Steps”	4-44
4.7.7	References	4-45
4.8	Liquid Desiccant Air Conditioners.....	4-46
4.8.1	Summary	4-46
4.8.2	Background	4-48
4.8.3	Performance	4-50
4.8.4	Cost	4-52
4.8.5	Perceived Barriers to Market Adoption of Technology	4-52
4.8.6	Technology “Next Steps”	4-52
4.8.7	References	4-52
4.9	Microchannel Heat Exchangers	4-53
4.9.1	Summary	4-53
4.9.2	Background	4-54
4.9.3	Cost	4-57
4.9.4	Performance	4-57
4.9.5	Perceived Barriers to Market Adoption of Technology	4-61
4.9.6	Technology Development “Next Steps”	4-62
4.9.7	References	4-62
4.10	Microenvironments (Task-Ambient Conditioning).....	4-62

4.10.1	Summary	4-62
4.10.2	Background	4-63
4.10.3	Performance	4-66
4.10.4	Cost	4-69
4.10.5	Perceived Barriers to Market Adoption of Technology	4-70
4.10.6	Technology “Next Steps”	4-70
4.10.7	References	4-71
4.11	Novel Cool Storage Concepts (Thermal Energy Storage [TES])	4-72
4.11.1	Summary	4-72
4.11.2	Background	4-73
4.11.3	Performance	4-75
4.11.4	Cost	4-77
4.11.5	Perceived Barriers to Market Adoption of Technology	4-79
4.11.6	Technology Development “Next Steps”	4-79
4.11.7	References	4-79
4.12	Radiant Ceiling Cooling / Chilled Beam	4-80
4.12.1	Summary	4-80
4.12.2	Background	4-81
4.12.3	Performance	4-83
4.12.4	Cost	4-85
4.12.5	Perceived Barriers to Market Adoption of Technology	4-85
4.12.6	Technology “Next Steps”	4-85
4.12.7	References	4-86
4.12.8	Appendix	4-86
4.13	Smaller Centrifugal Compressors	4-87
4.13.1	Summary	4-87
4.13.2	Background	4-88
4.13.3	Cost	4-90
4.13.4	Perceived Barriers to Market Adoption of Technology	4-90
4.13.5	Technology “Next Steps”	4-90
4.14	References	4-90
4.15	System/Component Diagnostics	4-91
4.15.1	Summary	4-91
4.15.2	Background	4-92
4.15.3	Performance	4-93
4.15.4	Cost	4-95
4.15.5	Perceived Barriers to Market Adoption of Technology	4-97
4.15.6	Technology “Next Steps”	4-97
4.15.7	References	4-98
4.16	Variable Refrigerant Volume/Flow	4-99
4.16.1	Summary	4-99
4.16.2	Background	4-100
4.16.3	Performance	4-102
4.16.4	Cost	4-102
4.16.5	Perceived Barriers to Market Adoption of Technology	4-103
4.16.6	Technology “Next Steps”	4-104
4.16.7	References:	4-104

5 CONCLUSIONS.....	5-1
REFERENCES	5-5
APPENDIX A: DATA SHEETS FOR 40 TECHNOLOGIES STUDIED IN MORE DETAIL	
APPENDIX B: THE ORIGINAL LIST OF 175 OPTIONS	

LIST OF FIGURES

FIGURE 1-1: PROJECT APPROACH SUMMARY.....	1-2
FIGURE 1-2: TECHNOLOGY OPTIONS WITH SIGNIFICANT ENERGY SAVINGS POTENTIAL (NOT SELECTED FOR REFINED STUDY)	1-4
FIGURE 1-3: ESTIMATED TECHNICAL ENERGY SAVINGS POTENTIAL AND SIMPLE PAYBACK PERIODS FOR THE 15 OPTIONS.....	1-6
FIGURE 2-1: COMMERCIAL BUILDING PRIMARY ENERGY CONSUMPTION BREAKDOWN (FROM BTS, 2001; ADL, 1999; ADL, 2001)	2-2
FIGURE 3-1: STEPS OF THE TECHNOLOGY OPTION SELECTION PROCESS	3-1
FIGURE 4-1: SCHEMATIC OF A DEDICATED OUTDOOR AIR SYSTEM (FROM MUMMA, 2001A).....	4-9
FIGURE 4-2: ILLUSTRATIONS OF MIXING (TOP) AND DISPLACEMENT VENTILATION (BOTTOM)	4-16
FIGURE 4-3: SUB-FRACTIONAL HORSEPOWER MOTOR EFFICIENCIES (FOR REFRIGERATOR FAN MOTORS, FROM ADL, 1999)	4-26
FIGURE 4-4: BRUSHLESS DC AND PSC MOTOR OEM COSTS (FOR REFRIGERATOR FAN APPLICATION, FROM ADL, 1999)	4-28
FIGURE 4-5: GENERIC CONFIGURATION OF AN AIR-TO-AIR HEAT EXCHANGER USED FOR ENERGY RECOVERY IN VENTILATION APPLICATIONS	4-31
FIGURE 4-6: IN A TIGHTLY CONSTRUCTED BUILDING, THE EXHAUST AIRFLOW RATE THROUGH THE ERV EQUALS A SIGNIFICANT PORTION OF THE MAKE-UP AIR FLOW RATE	4-32
FIGURE 4-7: UNITARY AIR CONDITIONER WITH A FACTORY INTEGRATED AAHX	4-33
FIGURE 4-8: ADD-ON ACCESSORY ERV WITH SUPPLY AND EXHAUST BLOWERS PLUS A UNITARY AIR CONDITIONER	4-33
FIGURE 4-9: FLANGED DUCT SYSTEM AS MANUFACTURED BY DURO-DYNE CORPORATION.....	4-45
FIGURE 4-10: BASIC CONFIGURATION OF A DESICCANT DEHUMIDIFIER	4-49
FIGURE 4-11: DESICCANT AIR CONDITIONER WITH EVAPORATIVELY-COOLED ABSORBER.....	4-49
FIGURE 4-12: DOUBLE-EFFECT REGENERATOR	4-50
FIGURE 4-13: MICROCHANNEL AND CONVENTIONAL HEAT EXCHANGER COMPARISON.....	4-55
FIGURE 4-14: COMPRESSION RING FITTING FOR CONNECTION OF ALUMINUM HEAT EXCHANGERS TO COPPER TUBES.....	4-56
FIGURE 4-15: JOHNSON CONTROLS' PERSONAL ENVIRONMENTS® SYSTEMS	4-64
FIGURE 4-16: TASK AIR™ BY TATE ACCESS FLOORS, INC.	4-64
FIGURE 4-17: ARGON CORPORATION PRODUCTS (DESK-MOUNTED AND CUBICLE-WALL MOUNTED)	4-65
FIGURE 4-18: THERMAL ENERGY STORAGE SYSTEM TANKS (FROM CALMAC MANUFACTURING CORP.)	4-73
FIGURE 4-19: ILLUSTRATIVE EXAMPLE OF HOW TES LEVELS CHILLER OUTPUT.....	4-74
FIGURE 4-20: SIMPLE MODEL OF TES IMPACT ON PRIMARY ENERGY CONSUMPTION.....	4-77
FIGURE 4-21: PRINCIPLES OF RADIANT CEILING PANEL COOLING	4-83

FIGURE 4-22: TWO-STAGE, BACK-TO-BACK CONFIGURATION, CENTRIFUGAL COMPRESSOR CROSS-SECTION (FROM BRONDUM ET AL., 1998)	4-89
FIGURE 4-23: REFRIGERANT ECONOMIZER CYCLE	4-89
FIGURE 4-24: SCHEMATIC DIAGRAM OF VRV™ SYSTEM WITH HEAT RECOVERY (FROM DAIKIN INDUSTRIES LTD.).....	4-102
FIGURE 5-1: ESTIMATED TECHNICAL ENERGY SAVINGS POTENTIAL OF TECHNOLOGY OPTIONS NOT SELECTED FOR 15	5-1
FIGURE 5-2: ESTIMATED TECHNICAL ENERGY SAVINGS POTENTIAL AND SIMPLE PAYBACK PERIODS FOR THE 15 OPTIONS.....	5-2

LIST OF TABLES

TABLE 1-1: THE 55 TECHNOLOGY OPTIONS SELECTED FOR FURTHER STUDY.....	1-3
TABLE 1-2: SUMMARY OF THE 15 TECHNOLOGY OPTIONS SELECTED FOR REFINED STUDY	1-5
TABLE 1-3: COMMON THEMES TO ENERGY CONSUMPTION REDUCTION	1-6
TABLE 1-4: COMMON NON-ENERGY BENEFITS OF THE 15 TECHNOLOGY OPTIONS.....	1-7
TABLE 1-5: TECHNOLOGY DEVELOPMENT POTENTIAL “NEXT STEPS” FOR THE 15 TECHNOLOGIES	1-8
TABLE 2-1: BREAKDOWN OF TYPICAL SMALL OFFICE BUILDING ANNUAL EXPENDITURES (FROM CLER ET AL., 1997)	2-5
TABLE 3-1: 55 OPTIONS SELECTED FOR FURTHER STUDY	3-3
TABLE 3-2: THE 15 TECHNOLOGY OPTIONS SELECTED FOR FURTHER EVALUATION.....	3-4
TABLE 4-1: ENERGY SAVINGS POTENTIAL SUMMARY FOR 15 OPTIONS	4-1
TABLE 4-2: COMMERCIAL BUILDING COOLING PRIMARY ENERGY CONSUMPTION BREAKDOWN (FROM ADL, 2001).....	4-2
TABLE 4-3: COMMERCIAL BUILDING HEATING PRIMARY ENERGY CONSUMPTION BREAKDOWN (FROM ADL, 2001).....	4-2
TABLE 4-4: COMMERCIAL BUILDING PARASITIC PRIMARY ENERGY CONSUMPTION BREAKDOWN (FROM ADL, 1999).....	4-2
TABLE 4-5: SUMMARY OF ADAPTIVE/FUZZY CONTROL CHARACTERISTICS	4-4
TABLE 4-6: SUMMARY OF DEDICATED OUTDOOR AIR SYSTEMS CHARACTERISTICS	4-8
TABLE 4-7: ENERGY SAVINGS OF DOAS VERSUS CONVENTIONAL VAV.....	4-12
TABLE 4-8: SUMMARY OF DISPLACEMENT VENTILATION CHARACTERISTICS	4-15
TABLE 4-9: ANNUAL SITE ENERGY SAVINGS FOR TOTAL U.S. ENERGY SAVINGS POTENTIAL ESTIMATE BY REGION AND BUILDING	4-19
TABLE 4-10: ZHIVOV AND RYMKEVICH (1998) COOLING ENERGY SAVINGS FOR DISPLACEMENT VENTILATION.....	4-20
TABLE 4-11: INDEPENDENT RESULTS FOR THIS STUDY SHOWING BENEFIT OF DISPLACEMENT VENTILATION IN SMALL OFFICE BUILDINGS.....	4-20
TABLE 4-12: ESTIMATED SIMPLE PAYBACK PERIOD FOR DISPLACEMENT VENTILATION SMALL OFFICES	4-22
TABLE 4-13: SUMMARY OF ELECTRONICALLY COMMUTATED PERMANENT MAGNET MOTOR CHARACTERISTICS.....	4-24
TABLE 4-14: FRACTIONAL HORSEPOWER BRUSHLESS DC MOTOR ENERGY SAVINGS POTENTIAL IN COMMERCIAL BUILDINGS (FROM ADL, 1999)	4-26
TABLE 4-15: SUMMARY OF ENTHALPY/ENERGY RECOVERY HEAT EXCHANGER FOR VENTILATION CHARACTERISTICS	4-30
TABLE 4-16: SUMMARY OF HEAT PUMP FOR COLD CLIMATES CHARACTERISTICS.....	4-36
TABLE 4-17: ENERGY AND COST COMPARISON TO FURNACE	4-39
TABLE 4-18: SUMMARY OF IMPROVED DUCT SEALING CHARACTERISTICS	4-42
TABLE 4-19: SUMMARY OF LIQUID DESICCANT AIR CONDITIONER CHARACTERISTICS.....	4-47
TABLE 4-20: LIQUID DESICCANT DOAS ENERGY SAVINGS DOAS AND CONVENTIONAL CYCLE DOAS	4-52
TABLE 4-21: SUMMARY OF MICROCHANNEL HEAT EXCHANGER CHARACTERISTICS	4-54

TABLE 4-22: BASELINE ROOFTOP UNIT SUMMARY DATA	4-57
TABLE 4-23: PERFORMANCE COMPARISON OF BASELINE ROOFTOP UNIT AND MODIFIED UNITS USING MICROCHANNEL HEAT EXCHANGERS	4-58
TABLE 4-24: SUMMARY OF MICROENVIRONMENTS CHARACTERISTICS	4-63
TABLE 4-25: SUMMARY OF HOW MICROENVIRONMENTS AFFECT HVAC ENERGY	4-66
TABLE 4-26: SUMMARY OF THE FACTORS AFFECTING HVAC ENERGY IN FRESNO, CA (FROM BAUMAN ET AL., 1994)	4-68
TABLE 4-27: SUMMARY OF HOW DIFFERENT MICROENVIRONMENT SYSTEMS IMPACT HVAC ENERGY IN SAN JOSE, CA (FROM BAUMAN ET AL., 1994)	4-68
TABLE 4-28: TOTAL ENERGY SAVINGS POTENTIAL OF MICROENVIRONMENTS IN U.S. OFFICE BUILDINGS	4-69
TABLE 4-29: ESTIMATED SIMPLE PAYBACK PERIODS FOR MICROENVIRONMENTS IN 5 U.S. CITIES (BASED ON ENERGY SAVINGS ONLY)	4-70
TABLE 4-30: SUMMARY OF THERMAL ENERGY STORAGE (TES) CHARACTERISTICS	4-72
TABLE 4-31: THERMAL ENERGY STORAGE MODEL FOR A 100,000 FT ² OFFICE BUILDING IN ATLANTA	4-75
TABLE 4-32: TEMPERATURE IMPACT OF OFF-PEAK TES COOLING VERSUS ON-PEAK COOLING	4-76
TABLE 4-33: COMPARISON OF ON-PEAK AND OFF-PEAK HEAT RATE AND T&D LOSSES	4-76
TABLE 4-34: THERMAL ENERGY STORAGE COST ESTIMATES (FROM CLER ET AL., 1997)	4-78
TABLE 4-35: ENCAPSULATED WATER AND PCM TES COSTS (FROM OTT, 2000; INCLUDES 1.55 MARK-UP)	4-78
TABLE 4-36: IMPACT OF RATE STRUCTURE ON PCM-BASED TES ECONOMICS	4-79
TABLE 4-37: SUMMARY OF RADIANT CEILING COOLING CHARACTERISTICS	4-81
TABLE 4-38: ENERGY SAVINGS BY RADIANT COOLING SYSTEMS WITH DOAS VERSUS CONVENTIONAL VAV	4-84
TABLE 4-39: PEAK HVAC ENERGY CONSUMPTION COMPARISON, VAV VERSUS RADIANT COOLING (FROM STETIU, 1997)	4-87
TABLE 4-40: SUMMARY OF SMALLER CENTRIFUGAL COMPRESSOR CHARACTERISTICS	4-87
TABLE 4-41: SUMMARY OF SYSTEM/COMPONENT DIAGNOSTICS CHARACTERISTICS	4-91
TABLE 4-42: FAULT DETECTION: EQUIPMENT, FAULTS, AND METHODS	4-93
TABLE 4-43: ESTIMATED INCREASE IN COOLING ENERGY USE FOR UNITARY EQUIPMENT BASED ON POSSIBLE FAULT MODES	4-95
TABLE 4-44: ENERGY SAVINGS POTENTIAL FOR A FAST-FOOD RESTAURANT (ILLUSTRATIVE, FROM REFERENCE 4)	4-95
TABLE 4-45: DIAGNOSTIC SYSTEM INSTALLATION COST AND ECONOMICS FOR A FAST FOOD RESTAURANT	4-96
TABLE 4-46: SUMMARY OF VRV TM /VRF SYSTEM CHARACTERISTICS	4-100
TABLE 5-1: COMMON THEMES TO ENERGY CONSUMPTION REDUCTION	5-2
TABLE 5-2: COMMON NON-ENERGY BENEFITS OF THE 15 TECHNOLOGY OPTIONS	5-3
TABLE 5-3: TECHNOLOGY DEVELOPMENT POTENTIAL “NEXT STEPS” FOR THE 15 TECHNOLOGIES	5-3

1 EXECUTIVE SUMMARY

This report is the third volume of a three-volume set of reports on energy consumption in commercial building HVAC systems in the U.S. The first volume focuses on energy use for generation of heating and cooling, i.e. in equipment such as boilers and furnaces for heating and chillers and packaged air-conditioning units for cooling. The second volume focused on “*parasitic*” energy use or the energy required to distribute heating and cooling within a building, reject to the environment the heat discharged by cooling systems, and move air for ventilation purposes. This third volume addresses opportunities for energy savings in commercial building HVAC systems, specifically technology options and their technical energy savings potential, current and future economic suitability, and the barriers preventing widespread deployment of each technology in commercial building HVAC systems.

1.1 Study Objectives

The objectives of this study were to:

- Identify the wide range of energy savings options applicable to commercial HVAC that have been proposed, developed or commercialized, and develop a rough estimate of each option’s energy saving potential;
- Through successively more detailed analysis and investigation, improve the understanding of energy savings potential and key issues associated with realizing this potential for the technology options least well understood and/or considered most promising after initial study;
- Provide information about the technology options, including key references, that will aid interested parties in assessing each technology’s viability for specific application or program;
- Develop suggestions for developmental “next steps” towards achieving widespread commercialization for each technology option;
- Solicit industry review of the report to verify key conclusions and that important trends and barriers are identified.

Figure 1-1 summarizes the project approach.

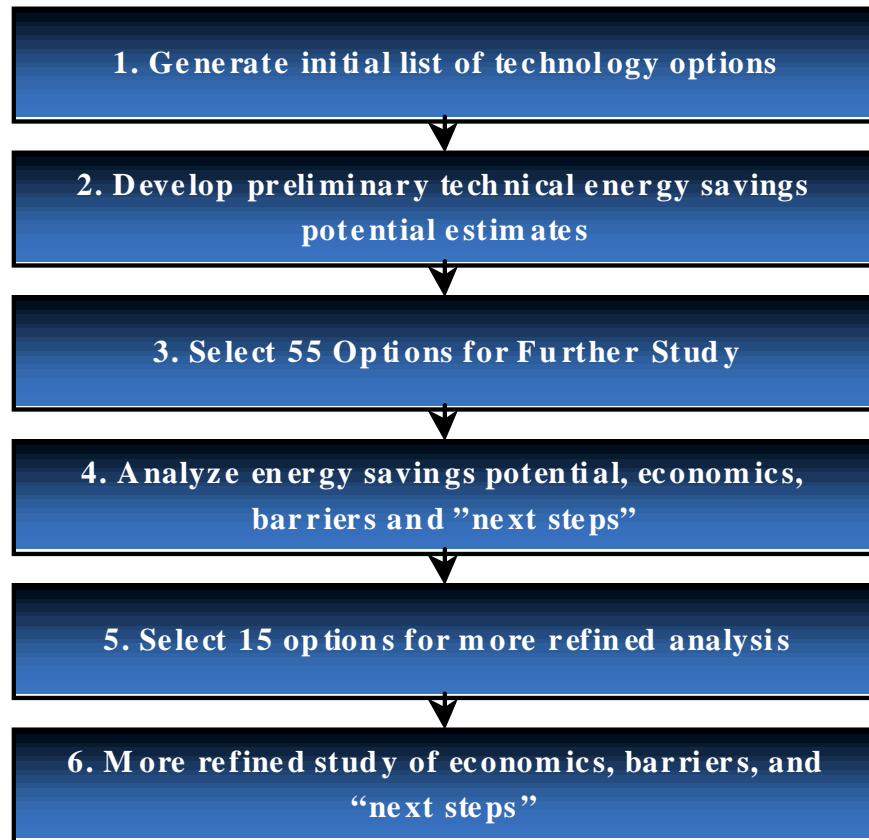

Figure 1-1: Project Approach Summary

It is important to note that selection or omission of a particular technology option at a given project stage does not endorse or refute any technical concept, i.e., no “winners” or “losers” are selected. The selected technologies, however, were considered of greater interest for further study, as guided by the nine industry experts who provided input. This philosophy was clearly reflected in the criteria for selecting the 15 options: energy saving potential *and* the value of further study toward improving estimates of ultimate market-achievable energy savings potential, notably the energy savings potential, current and potential future economics, and key barriers facing each option. Indeed, a number of the 40 options *not* selected for the “round of 15” had significantly greater energy savings potential than some of the 15, but further study would not have appreciably clarified their market-achievable energy savings potential.

1.2 Summary of Findings

Table 1-1 presents the 55 technologies selected for further study (at project step 3), grouped by type of technology option. Options in **bold** were also selected as part of the “round of 15” (step 5) refinement.

Table 1-1: The 55 Technology Options Selected for Further Study

<p>Component (24):</p> <ul style="list-style-type: none"> <input type="checkbox"/> Advanced Compressors <input type="checkbox"/> Advanced Desiccant Material <input type="checkbox"/> Backward-Curved/Airfoil Blower <input type="checkbox"/> Copper Rotor Motor <input type="checkbox"/> Direct-Contact Heat Exchanger <input type="checkbox"/> Electrodynamc Heat Transfer <input type="checkbox"/> Electronically Commutated Permanent Magnet Motor (ECPM) <input type="checkbox"/> Electrostatic Filter <input type="checkbox"/> Heat Pipe <input type="checkbox"/> High-Efficiency (Custom) Fan Blades <input type="checkbox"/> High-Temperature Superconducting Motor <input type="checkbox"/> Hydrocarbon Refrigerant <input type="checkbox"/> Improved Duct Sealing <input type="checkbox"/> Larger Fan Blade <input type="checkbox"/> Low-Pressure Refrigerant <input type="checkbox"/> Microchannel Heat Exchanger <input type="checkbox"/> Refrigerant Additive (to Enhance Heat Transfer) <input type="checkbox"/> Smaller Centrifugal Compressors <input type="checkbox"/> Twin-Single Compressor <input type="checkbox"/> Two-Speed Motor <input type="checkbox"/> Unconventional (Microscale) Heat Pipe <input type="checkbox"/> Variable-Pitch Fans <input type="checkbox"/> Variable-Speed Drive <input type="checkbox"/> Zeotropic Refrigerant 	<p>Equipment (10):</p> <ul style="list-style-type: none"> <input type="checkbox"/> Dual-Compressor Chiller <input type="checkbox"/> Dual-Source Heat Pump <input type="checkbox"/> Economizer <input type="checkbox"/> Enthalpy/Energy Recovery Heat Exchangers for Ventilation <input type="checkbox"/> Engine-Driven Heat Pump <input type="checkbox"/> Ground-Source Heat Pump <input type="checkbox"/> Heat Pump for Cold Climates <input type="checkbox"/> Liquid Desiccant Air Conditioner <input type="checkbox"/> Modulating Boiler/Furnace <input type="checkbox"/> Phase Change Insulation
<p>Systems (14):</p> <ul style="list-style-type: none"> <input type="checkbox"/> All-Water (versus All-Air) Systems <input type="checkbox"/> Alternative Air Treatment (to reduce OA) <input type="checkbox"/> Apply Energy Model to Properly Size HVAC equipment <input type="checkbox"/> Chemical Heat/Cooling Generation <input type="checkbox"/> Demand-Control Ventilation <input type="checkbox"/> Dedicated Outdoor Air Systems <input type="checkbox"/> Displacement Ventilation <input type="checkbox"/> Ductless Split System <input type="checkbox"/> Mass Customization of HVAC Equipment <input type="checkbox"/> Microenvironment (Task-ambient Conditioning) <input type="checkbox"/> Novel Cool Storage <input type="checkbox"/> Natural Refrigerants <input type="checkbox"/> Radiant Ceiling Cooling/Chilled Beam <input type="checkbox"/> Variable Refrigerant Volume/Flow 	<p>Controls / Operations (7):</p> <ul style="list-style-type: none"> <input type="checkbox"/> Adaptive/Fuzzy Logic HVAC Control <input type="checkbox"/> Building Automation System <input type="checkbox"/> Complete/Retro Commissioning <input type="checkbox"/> Finite State Machine Control <input type="checkbox"/> Personal Thermostat (e.g. Ring Thermostat) <input type="checkbox"/> Regular Maintenance <input type="checkbox"/> System/Component Performance Diagnostics

Many of the 40 technologies are estimated to have significant technical energy savings potentials. Figure 1-2 shows the estimated technical energy savings potentials for some of the options from Table 1-1 that were not selected for further analysis. Technical energy savings potential is defined as the annual energy savings that would occur relative to “typical new” equipment if the technology option immediately was installed components / equipment / systems / practices in all reasonable applications. It does not consider that the actual ultimate market penetration would be less than 100%, nor the time required for technologies to diffuse into the market. Furthermore, the technical energy savings potentials clearly are not additive, as application of one option may reduce the energy savings achievable by other options or preclude the application of other options. Nonetheless, the

technical energy savings potentials indicate the potential for considerable reduction of the 4.5 quads of primary energy consumed by HVAC systems in commercial buildings.

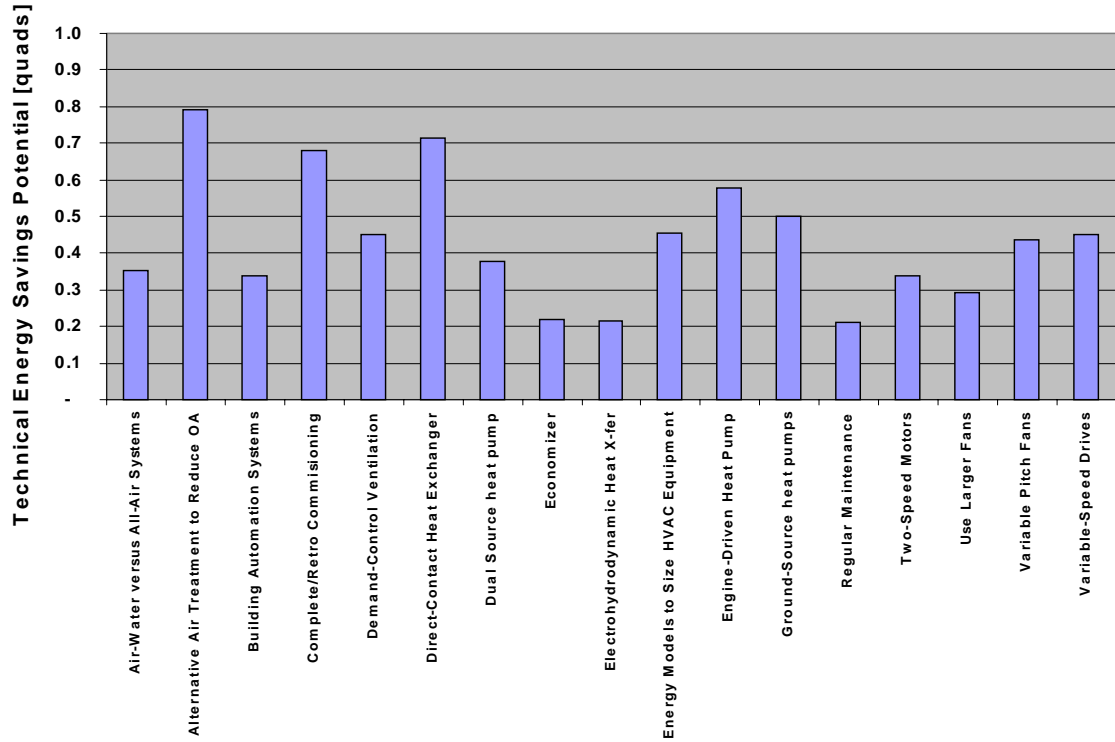

Figure 1-2: Technology Options with Significant Energy Savings Potential (not selected for refined study)

Table 1-2 displays the 15 technologies selected for refined study, including their technology status and technical energy savings potentials. The “technology status” entries are defined as:

- *Current*: Technologies that are currently in use but have not achieved broad market penetration;
- *New*: Technologies that are commercially-available but presently not used in commercial building HVAC equipment and systems;
- *Advanced*: Technologies yet to be commercialized or demonstrated and which require research and development.

Table 1-2: Summary of the 15 Technology Options Selected for Refined Study

Technology Option	Technology Status	Technical Energy Savings Potential (quads)
Adaptive/Fuzzy Logic Controls	New	0.23
Dedicated Outdoor Air Systems	Current	0.45
Displacement Ventilation	Current	0.20
Electronically Commutated Permanent Magnet Motors	Current	0.15
Enthalpy/Energy Recovery Heat Exchangers for Ventilation	Current	0.55
Heat Pumps for Cold Climates (Zero-Degree Heat Pump)	Advanced	0.1
Improved Duct Sealing	Current/New	0.23
Liquid Desiccant Air Conditioners	Advanced	0.2 / 0.06 ¹
Microchannel Heat Exchanger	New	0.11
Microenvironments / Occupancy-Based Control	Current	0.07
Novel Cool Storage	Current	0.2/ 0.03 ²
Radiant Ceiling Cooling / Chilled Beam	Current	0.6
Smaller Centrifugal Compressors	Advanced	0.15
System/Component Diagnostics	New	0.45
Variable Refrigerant Volume/Flow	Current	0.3

The body of the report contains in-depth discussions of the options, including development of estimated energy savings potential, economics (general estimates of installed costs and simple payback periods), commercialization barriers, and developmental “next steps”. Many – but not all – of the 15 options had attractive and/or reasonable simple payback periods (see Figure 1-3).

¹ The two energy savings estimates presented for Liquid Desiccant Air Conditioners are for use as a DOAS and relative to a conventional DOAS, respectively.

² The two energy savings estimates presented for the Novel Cool Storage option are for all packaged and chiller systems and only water-cooled chillers, respectively

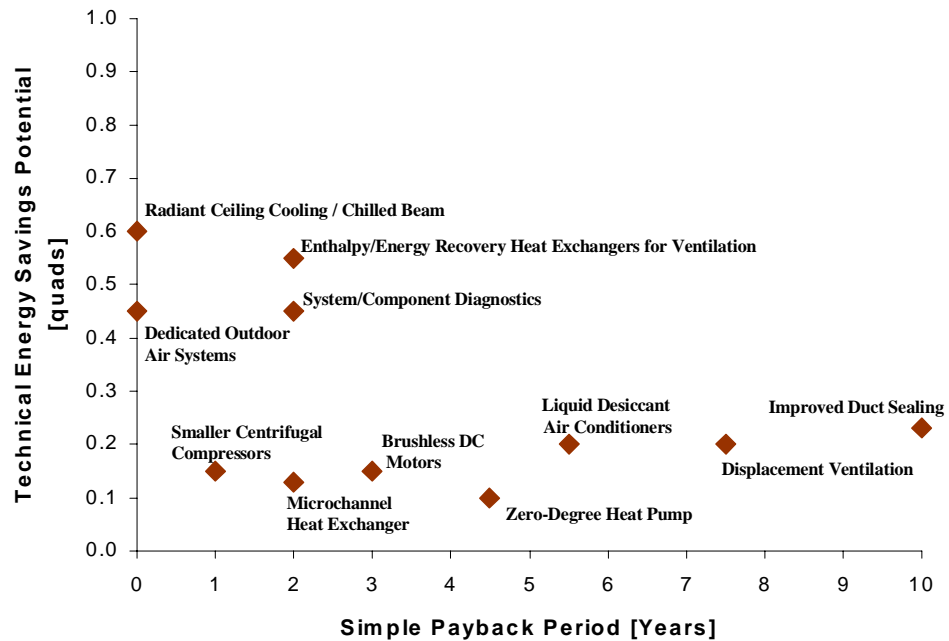

Figure 1-3: Estimated Technical Energy Savings Potential and Simple Payback Periods for the 15 Options

Three of the options, Novel Cool Storage, Variable Refrigerant Volume/Flow, and Adaptive/Fuzzy Control, had highly variable simple payback periods that did not readily translate into an average simple payback period, while the simple payback period for Microenvironments exceeded 100 years.

Overall, some common themes arise as to how the 15 technologies reduce energy consumption (see Table 1-3).

Table 1-3: Common Themes to Energy Consumption Reduction

Energy Consumption Reduction Theme	Relevant Technologies
<i>Separate Treatment of Ventilation and Internal Loads</i>	<ul style="list-style-type: none"> • Dedicated Outdoor Air Systems (DOAS) • Radiant Ceiling Cooling • Liquid Desiccant for Ventilation Air Treatment • Energy Recovery Ventilation • Displacement Ventilation
<i>Fix Common HVAC Problems</i>	<ul style="list-style-type: none"> • Adaptive/Fuzzy Control • Improved Duct Sealing • System/Component Diagnostics
<i>Improved Delivery of Conditioning Where Needed</i>	<ul style="list-style-type: none"> • Microenvironments • Displacement Ventilation • Variable Refrigerant Volume/Flow • Adaptive/Fuzzy Logic Control
<i>Improved Part-Load Performance</i>	<ul style="list-style-type: none"> • Electronically Commutated Permanent Magnet Motors • Smaller Centrifugal Compressors • Variable Refrigerant Volume/Flow

In particular, the separate treatment of ventilation and internal loads has received continued attention, driven by increased concerns about indoor air quality (IAQ). The other three major themes of Table 1-3 have always played an important part of HVAC system energy conservation work.

Several of the 15 share common non-energy benefits that can, in some cases, significantly enhance their commercial potential (see Table 1-4).

Table 1-4: Common Non-Energy Benefits of the 15 Technology Options

Non-Energy Benefit	Relevant Technologies
<i>Down-Sizing of HVAC Equipment</i>	<ul style="list-style-type: none"> • Dedicated Outdoor Air Systems (DOAS) • Radiant Ceiling Cooling • Enthalpy/Energy Recovery Exchangers for Ventilation • Displacement Ventilation • Novel Cool Storage • Liquid Desiccant Air Conditioner for Ventilation Air Treatment. • Variable Refrigerant Volume/Flow
<i>Enhanced Indoor Air Quality</i>	<ul style="list-style-type: none"> • Displacement Ventilation • Liquid Desiccant Air Conditioner
<i>Improved Humidity Control</i>	<ul style="list-style-type: none"> • Dedicated Outdoor Air Systems (DOAS) • Enthalpy Recovery Exchangers for Ventilation • Liquid Desiccant Air Conditioner
<i>Notable Peak Demand Reduction</i>	<ul style="list-style-type: none"> • Novel Cool Storage • Dedicated Outdoor Air Systems • Enthalpy/Energy Recovery Exchangers for Ventilation • Improved Duct Sealing • Radiant Cooling / Chilled Beam • Variable Refrigerant Volume/Flow

To varying degrees, all technology options face real or perceived economic barriers to entering the market. Beyond economics, the largest single market barrier impeding several of the 15 technology options is that they are unproven in the market. In some cases, notably variable refrigerant volume/flow, radiant ceiling cooling, and displacement ventilation, of those, the options have found significant use abroad but remain unfamiliar within the U.S. HVAC community. Owing to the different barriers and developmental stages of the different options, the options have a wide range of potential “next steps” (see Table 1-5).

Table 1-5: Technology Development Potential “Next Steps” for the 15 Technologies

Potential “Next Step”	Relevant Technologies
<i>More Research and/or Study</i>	<ul style="list-style-type: none"> • Adaptive/Fuzzy Logic Control • Heat Pump for Cold Climates (CO₂ cycle) • Liquid Desiccant Air Conditioner • Small Centrifugal Compressor • System/Component Diagnostics
<i>Education</i>	<ul style="list-style-type: none"> • Dedicated Outdoor Air Systems (DOAS) • Displacement Ventilation • Enthalpy/Energy Recovery Exchangers for Ventilation • Radiant Ceiling Cooling • Variable Refrigerant Volume
<i>Demonstration</i>	<ul style="list-style-type: none"> • Displacement Ventilation • Improved Duct Sealing • Radiant Ceiling • Variable Refrigerant Volume/Flow
<i>Market Conditioning, etc.</i>	<ul style="list-style-type: none"> • Electronically Commutated Permanent Magnet Motors • Enthalpy/Energy Recovery Exchangers for Ventilation • Microchannel Heat Exchangers

Several factors characterize the most promising areas for the application of the 15 technology options, and HVAC energy-efficiencies in general. First, the economics of energy-efficient equipment improve in regions with high electricity and gas rates. For cooling and ventilation technologies, higher demand charges can also result in shorter simple payback periods. Second, as noted in ADL (1999), packaged rooftop equipment presents several opportunities for more cost-effective efficiency gains due to the lower efficiency equipment typically employed. Third, institutional purchasers (governments, hospitals, educational establishments, etc.) tend to have a longer time horizon than most commercial enterprises, reducing their sensitivity to first-cost premium and making HVAC technologies with reasonable payback periods more attractive. Fourth, in many instances hospitals should be a preferred building type for more efficient equipment and systems, as they consume high levels of HVAC energy because of ‘round the clock operations and high OA requirements, and are often long-standing institutions willing to invest more funds up front provided they reap a solid return over the equipment lifetime.

Finally, many of the 15 options could be readily retrofit into existing equipment or buildings, which would allow them to penetrate the existing building stock much more rapidly than technologies limited primarily to new construction/major renovation. Options that are particularly suited for a retrofit include: Adaptive/Fuzzy Logic Control, System Diagnostics, and Improved Duct Sealing (e.g., aerosol-based). In addition, component- and equipment-level technology options could also penetrate the market reasonably quickly by replacement of existing HVAC equipment at the end of its lifetime.

2 INTRODUCTION

This report is the third volume of a three-volume set of reports on energy consumption by commercial building HVAC systems in the U.S. The first two volumes were completed by Arthur D. Little, Inc. (ADL), and this third volume by TIAX LLC, formerly the Technology & Innovation business of ADL. Many of the same people have contributed to all three volumes, lending continuity to the three-volume endeavor.

The first volume, “Energy Consumption Characteristics of Commercial Building HVAC Systems : Chillers, Refrigerant Compressors, and Heating Systems”, focused on energy use for generation of heating and cooling, i.e. in equipment such as boilers and furnaces for heating and chillers and packaged air-conditioning units for cooling (ADL, 2001). The second volume, “Energy Consumption Characteristics of Commercial Building HVAC Systems: Thermal Distribution, Auxiliary Equipment, and Ventilation”, focused on “*parasitic*” energy use or the energy required to distribute heating and cooling within a building, reject to the environment the heat discharged by cooling systems, and move air for ventilation purposes (ADL, 1999). This third volume addresses opportunities for energy savings in commercial building HVAC systems.

Volumes 1 and 2 contain much of the background information regarding HVAC system types, market characterization, etc., and the energy savings potential calculations rely upon the detailed breakdowns of energy consumption put forth in these documents. Hence, the reader is encouraged to refer to Volumes 1 and 2 as required to supplement this report.

2.1 Background

The first and second volumes of the triumvirate of commercial HVAC reports found that commercial building HVAC systems consumed a total of 4.5³ quads of primary energy⁴ in 1995, representing the largest primary energy end-use in commercial buildings (other values from BTS, 2001, in 1995; see Figure 2-1). Of the roughly 59 billion square feet of commercial floorspace, about 82% is heated and 61% is cooled.

³ The sum of the primary energy consumption quantities in Figures 2-1, 2-2 and 2-3 exceed 4.5 quads due to rounding of the individual quantities.

⁴ Primary energy, as opposed to site energy, takes into account the energy consumed at the electric plant to generate the electricity. On average, each kWh of electricity produced in Y2000 consumed 10,958 Btu (BTS, 2001).

Total = 14.7 quads (primary)

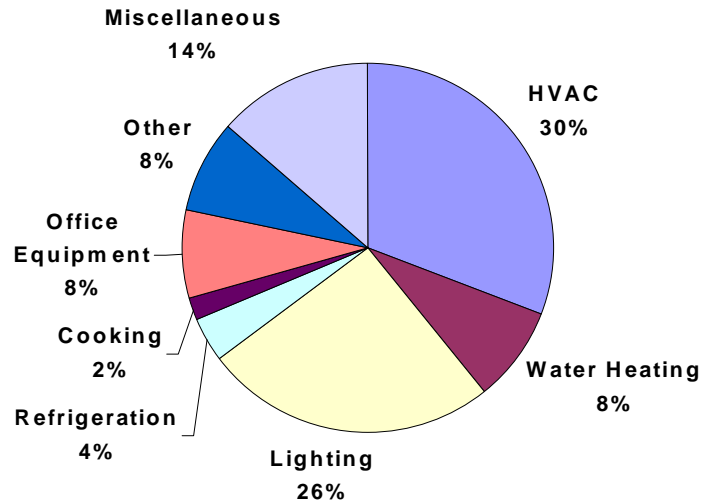

Figure 2-1: Commercial Building Primary Energy Consumption Breakdown (from BTS, 2001; ADL, 1999; ADL, 2001)

Commercial building HVAC primary energy consumption is relatively evenly distributed between heating, cooling, and “parasitic” end-uses (see Figures 2-2, 2-3 and 2-4, from ADL, 1999 and ADL, 2001).

**Cooling Energy Consumption
Total 1.4 quads (primary)**

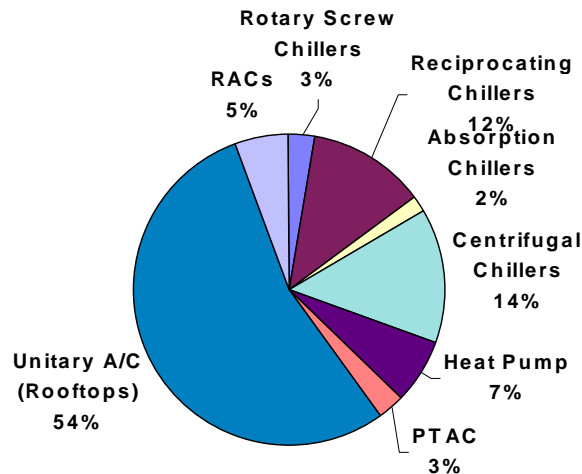

Figure 2-2: Commercial Building Cooling Energy Consumption in 1995 (from ADL, 2001)

**Heating Energy Consumption
Total = 1.7 quads (primary)**

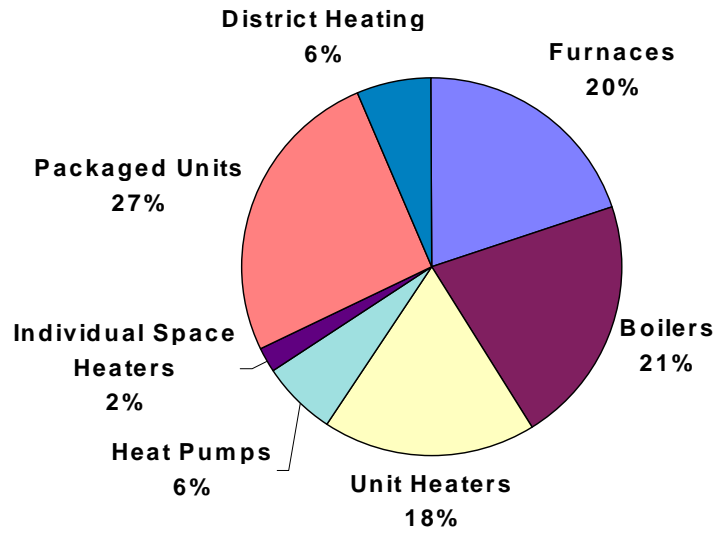

Figure 2-3: Commercial Building Heating Energy Consumption in 1995 (from ADL, 2001)

**Parasitic Energy Consumption
Total = 1.5 quads (primary)**

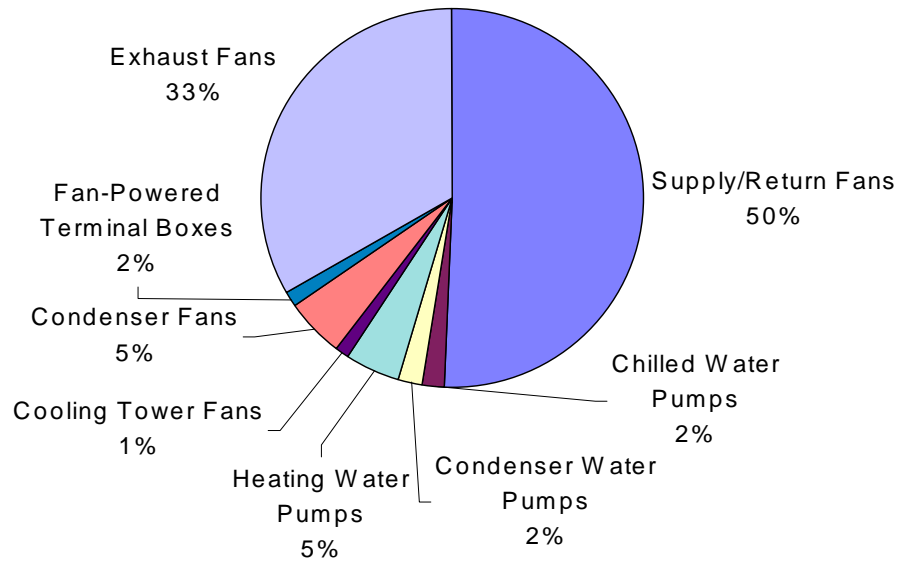

Figure 2-4: Commercial HVAC Parasitic Energy in 1995 (from ADL, 1999)

These energy consumption baselines formed the basis for all energy savings potential estimates calculated in this report.

Energy use for heating and cooling has long been a target for reduction efforts. In fact, significant efficiency improvements have been achieved over the years in these efforts. For example, the efficiency of a typical centrifugal chiller has increased 34% over the past 20 years (HVAC&R News, 1997). Energy use reductions have been achieved by the efforts of a wide range of players in the market, including manufacturers, contractors, specifying engineers, and government laboratories and agencies. In spite of these efforts, energy use for space conditioning remains a very large portion of the total national energy use picture and still provides significant opportunity for energy use reduction.

On the other hand, historically, several factors have hindered energy efficiency gains. For most businesses, energy is not a core part of the business. Consequently, many businesses are unwilling to make substantial investments in energy efficiency improvements that would displace core capital investments or potentially disrupt core functions⁵, even if the energy efficiency improvements have very favorable return-on-investment characteristics⁶. Tax codes effectively pose a barrier to energy savings in companies, as energy expenses are deductible business expenses, while energy investments count against capital (Hawken et al., 1999). Similarly, budget structures can impede energy-efficiency investments, even with acceptable payback structures, because a facility may have distinct construction and operating budgets that are not fungible (RLW Analytics, 1999). Corporate billing methods often work against energy efficiency investments as well by not directly billing entities for energy expenses. For instance, most firms do not keep track of energy costs as a line item for each cost center and many companies, most notably chains/franchises, do not even see energy bills as they are handled and paid at a remote location (Hawken et al., 1999).

When new buildings are built⁷ or major renovations undertaken, contracting practices often impede the use of energy efficiency in new construction. To save time and cost and avoid the potential risk of different HVAC system designs, design firms may simply copy old designs and specifications that worked in the past, preventing consideration of more efficient system designs and/or equipment options. Finally, energy costs simply do not represent a significant portion of expenditures for most buildings, e.g., one study found that energy expenditures account for just over 1% of *total* annual expenditures for a medium-sized office building, with HVAC expenses on the order of 0.5% (see Table 2-1, from Cler et al., 1997).

⁵ De Saro (2001) notes that the risk of incorporating the new energy-saving innovation and upsetting ongoing work (restaurant or retail sales, business function, office productivity, etc.) cannot be many times larger than the benefit, or the owner will rationally not adopt the new (and potentially disruptive) practice.

⁶ Many corporations have an ROI hurdle of 25% for core capital investments, which corresponds to a simple payback period of about 3.6 years for a marginal tax rate of 36%.

⁷ Data from EIA (1999) suggests that annual commercial building new construction equals about 1.5% of the commercial building stock; in contrast, the main heating and cooling equipment are replaced roughly every 15 years.

Table 2-1: Breakdown of Typical Small Office Building Annual Expenditures (from Cler et al., 1997)

Expenditure	Annual Cost, \$/ft ²
Office-Workers' Salaries	130
Gross Office Rent	21
Total Energy Use	1.81
Electricity Use	1.53
Repair and Maintenance	1.37
Space Cooling and Air Handling Electricity	0.61 ⁸
Space Cooling and Air Handling Maintenance	0.82
Total Building Operations and Management Salaries	0.58

Figure 2-5 provides a general idea of the market penetration levels achieved *on average* for different commercial HVAC product as a function of their simple payback period, based on past experience. It clearly shows that unless a technology has a simple payback period of less than two or three years, it will likely not achieve significant market penetration.

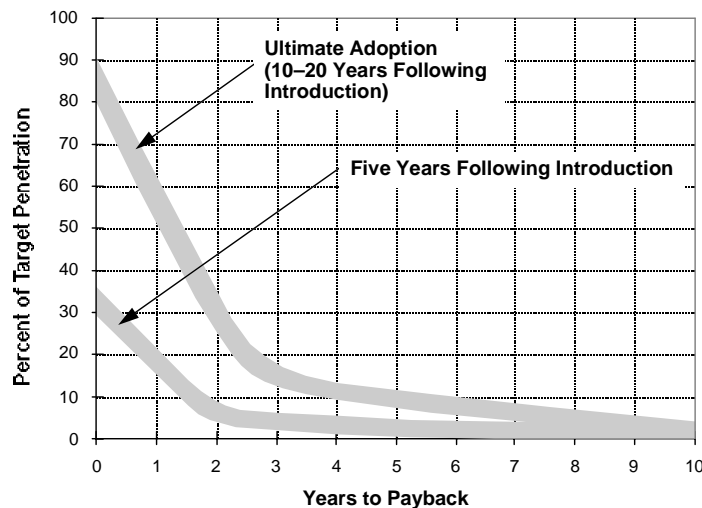

Sources: Arthur D. Little estimates, based on HVAC penetration experience

Figure 2-5: Estimate of Market Penetration Curve for Commercial HVAC Equipment

Although the fact that HVAC energy consumption only accounts for a miniscule portion of office building annual expenditures works strongly against energy efficiency investments, the dominance of worker salaries suggest that any HVAC technologies that enhance the productivity of workers, even by only 1% or 2%, would be very attractive investments⁹ that could realize significant market penetration. The net energy impact of measures that improve productivity is unclear, as some tend to increase HVAC energy consumption (e.g., increased outdoor air intake) while others tend to decrease HVAC energy consumption (e.g., displacement ventilation).

⁸ Using a rough average of the prices paid by commercial end users for electricity and gas circa 2000, i.e., \$0.07/kWh of electricity and \$5.50/MMBtu of gas, the Volume 1 energy consumption breakdown yields an average expenditure of \$0.50/ft² for electricity and \$0.09/ft² for gas per year, for a total \$0.59/ft² per year for year (average prices estimated from data provided by the EIA: <http://www.eia.doe.gov/cneaf/electricity/epm/epmt53p1.html> and http://www.eia.doe.gov/oil_gas/natural_gas/info_glance/sector.html).

⁹ See, for example, Fisk (2000) for more information.

2.2 Study Approach

Volume 3 was a detailed examination of energy-saving technologies applied to HVAC equipment and systems in commercial buildings. At its very essence, the project examined a portfolio of technology options that potentially save energy, with selected options successively receiving more thorough examination. Although the project attempted to select the technology options perceived to have greater energy savings potential for more study, it is important to note that this project did not select “winners”, i.e., omission of a technology at a given point of the project does not necessarily mean that the technology has negligible promise.

The initial list of 175 technology options came from a review of the existing HVAC literature, as well as a survey of ongoing HVAC research. Each technology was characterized by its maturity stage (see Table 2-2).

Table 2-2: Descriptions of Technology Technical Maturity Stages

Technical Maturity Stage	Description
<i>Current</i>	Technologies which are currently available, but not in broad market areas
<i>New</i>	Technologies which are commercially available, but presently not in use for HVAC equipment and systems
<i>Advanced</i>	Technologies which have not yet been commercialized or demonstrated and for which research and development is still needed

In addition, the technologies were also identified by type (see Table 2-3).

Table 2-3: Technology Type Classifications

Application Type	Examples
<i>Component</i>	Electrodynamic Heat Transfer (for Heat Exchangers); Airfoil Fan Blades; Advanced Desiccant Materials
<i>Equipment</i>	Triple-Effect Absorption Chillers; Phase Change Insulation
<i>System</i>	Displacement Ventilation; Microenvironments; Dedicated Outdoor Air Systems
<i>Controls / Operations / Maintenance</i>	Adaptive/Fuzzy Logic HVAC Control Algorithms; Complete Commissioning; Building Automation Systems

Subsequently, HVAC industry, DOE, and TIAX experts selected 55 of the initial 175 technology options for further study, based on their personal estimates of the technologies with the greatest technical and market-achievable energy savings potential. Further study of the 55 included developing improved energy savings estimates, economic information, as well as identifying key barriers to widespread commercialization of each technology and potential development “next” steps to overcome the barriers. Appendix A presents the write-ups of 40 of the 55 technologies; each write-up is approximately two pages in length.

Lastly, TIAX and DOE chose 15 of the 55 technology options for more refined evaluation, based on market-achievable energy savings potential and the perceived value of additional

study. Section 4 contains the detailed write-ups for each of the 15 technology options selected.

2.3 Report Organization

The Volume 3 report has the following organization:

Section 3 describes the process used to select the 175, 55, and 15 technology options.

Section 4 presents the 15 technology options¹⁰ selected for more refined study and spends several pages explaining each technology, including its energy savings potential, economics, barriers to widespread commercialization, and developmental “next steps”.

Section 5 presents the conclusions of this report, and recommendations for further study.

¹⁰ Appendix A contains similar (but less detailed) analyses for the 40 options (of the 55) not selected for further study.

3 ENERGY SAVING TECHNOLOGY SELECTION PROCESS

Figure 3-1 outlines the overall project flow that was used to select and assess technologies that could reduce energy consumption by HVAC systems in commercial buildings.

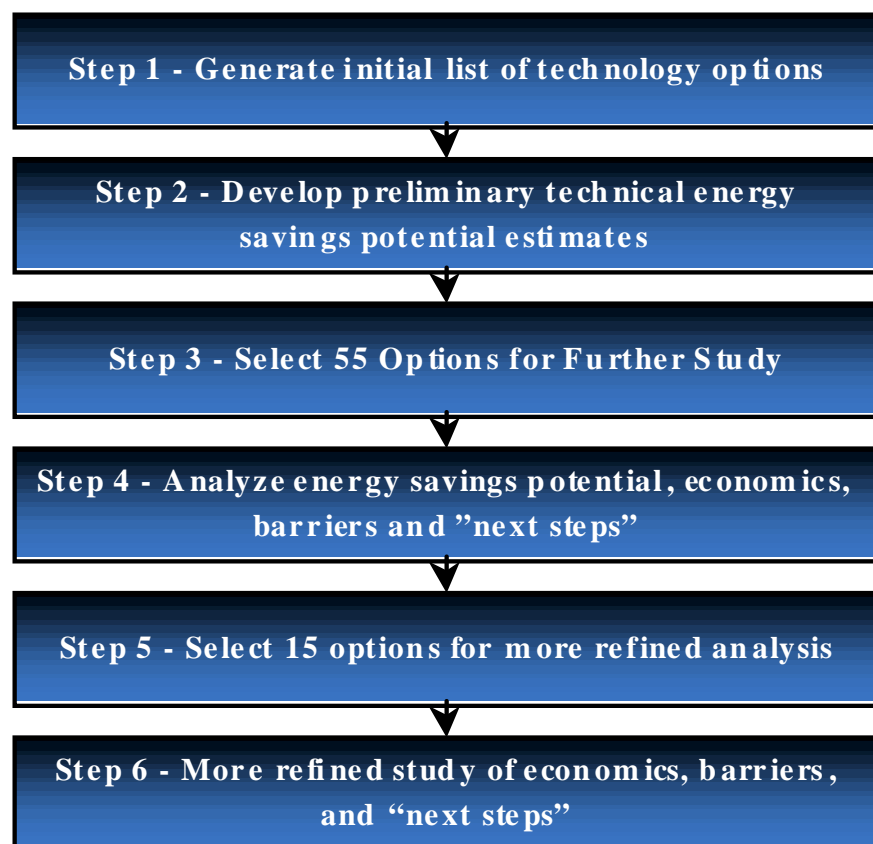

Figure 3-1: Steps of the Technology Option Selection Process

The following sub-sections explain each step of the technology option selection process in more detail.

3.1 Initial List of Technology Options (Steps 1 and 2)

An initial list of technology options that could potentially reduce the energy consumption of HVAC systems in commercial buildings comes from a variety of sources, including:

- ◆ HVAC Publications (*ASHRAE Journal*, *HPAC*, *Engineered Systems Magazine*, etc.);
- ◆ University HVAC Research (ASHRAE Research Projects, Purdue University, University of Illinois, Urbana-Champaign, etc.);

- ◆ The wider HVAC literature (National Laboratory Reports, past ADL studies, etc.);
- ◆ TIAX¹¹ and DOE personnel.

To enable consideration of a very broad range of technologies, the initial list was designed to be inclusive. As such, it included many technologies that may not save substantial quantities of energy (or any energy at all!) and ideas of questionable merit (e.g., major issues with technical feasibility and/or economic viability. Appendix B lists the 170 technologies initially considered.

On the other hand, the initial technology list only included technologies that directly impacted HVAC systems and had the potential to reduce HVAC energy consumption. Thus, the technology list did not consider co-generation or waste-heat utilization opportunities that did not save energy by themselves, e.g., systems that would use “waste” heat from HVAC to reduce water heating energy consumption. In addition, the study did not consider programmatic options which do not fundamentally reflect a certain technology, such as real-time electricity pricing or development of seasonal ratings of unitary equipment (i.e. SEER) in the commercial equipment size range. Building envelope technologies that reduce building heating or cooling loads were also not included, e.g., triple-pane windows. Finally, the study did not consider renewable energy technologies (e.g., solar heating). Without eliminating these classes of options, the study’s scope could have grown dramatically, compromising the intended focus on HVAC energy savings opportunities.

3.2 Selecting 55 Options for Further Study (Step 3)

After completion of the initial list of ~170 energy saving options and developing preliminary technical energy savings potential estimates for each, TIAX asked a variety of industry, DOE, and TIAX experts in HVAC to select the options that they believe exhibited the greatest promise to reduce energy consumption of HVAC systems in commercial buildings. The voters received the following instructions:

1. Base selections on your perception of Technical Energy Savings Potential and Market-Achievable Energy Savings Potential;
2. Select up to 20 3-point options;
3. Select up to 40 1-point options.

The ability to assign greater weight (3 points) to certain options enabled voters to specify options that they believed to be particularly promising.

The tally of the votes identified about 40 clear-cut technologies for further study, and consultation with the DOE program manager led to the selection of an additional 15 options, for a total of 55 technology options.

¹¹ TIAX was formerly the Technology & Innovation business of Arthur D. Little, Inc.

3.3 Further Study of the 55 Options (Step 4)

The 55 technology options shown in Table 3-1 were selected for further study.

Table 3-1: 55 Options Selected for Further Study

<p>Component (23):</p> <ul style="list-style-type: none"> <input type="checkbox"/> Advanced Compressor <input type="checkbox"/> Advanced Desiccant Material <input type="checkbox"/> Backward-Curved/Airfoil Blower <input type="checkbox"/> Brushless DC Motors <input type="checkbox"/> Copper Rotor Motor <input type="checkbox"/> Direct-Contact Heat Exchanger <input type="checkbox"/> Two-Speed Motor <input type="checkbox"/> Electrodynamical Heat Transfer <input type="checkbox"/> Electrostatic Filter <input type="checkbox"/> Heat Pipe <input type="checkbox"/> High-Efficiency (Custom) Fan Blades <input type="checkbox"/> High-Temperature Superconducting Motor <input type="checkbox"/> Hydrocarbon Refrigerant <input type="checkbox"/> Improved Duct Sealing <input type="checkbox"/> Larger Fan Blade <input type="checkbox"/> Low-Pressure Refrigerant <input type="checkbox"/> Microchannel Heat Exchanger <input type="checkbox"/> Natural Refrigerants <input type="checkbox"/> Refrigerant Additive (to Enhance Heat Transfer) <input type="checkbox"/> Twin-Single Compressor <input type="checkbox"/> Unconventional (Microscale) Heat Pipe <input type="checkbox"/> Variable-Pitch Fans <input type="checkbox"/> Zeotropic Refrigerant 	<p>Equipment (12):</p> <ul style="list-style-type: none"> <input type="checkbox"/> Dual-Compressor Chiller <input type="checkbox"/> Dual-Source Heat Pump <input type="checkbox"/> Economizer <input type="checkbox"/> Enthalpy/Energy Recovery Heat Exchangers for Ventilation <input type="checkbox"/> Engine-Driven Heat Pump <input type="checkbox"/> Ground-Source Heat Pump <input type="checkbox"/> Heat Pump for Cold Climates <input type="checkbox"/> Liquid Desiccant Air Conditioner <input type="checkbox"/> Modulating Boiler/Furnace <input type="checkbox"/> Phase Change Insulation <input type="checkbox"/> Smaller Centrifugal Compressors <input type="checkbox"/> Variable-Speed Drive
<p>Systems (12):</p> <ul style="list-style-type: none"> <input type="checkbox"/> All-Water (versus All-Air) Systems <input type="checkbox"/> Alternative Air Treatment (to reduce OA) <input type="checkbox"/> Apply Energy Model to Properly Size HVAC equipment <input type="checkbox"/> Chemical Heat/Cooling Generation <input type="checkbox"/> Demand-Control Ventilation <input type="checkbox"/> Displacement Ventilation <input type="checkbox"/> Ductless Split System <input type="checkbox"/> Mass Customization of HVAC Equipment <input type="checkbox"/> Microenvironment (Task-ambient Conditioning) <input type="checkbox"/> Novel Cool Storage <input type="checkbox"/> Radiant Ceiling Cooling/Chilled Beam <input type="checkbox"/> Variable Refrigerant Volume/Flow 	<p>Controls / Operations (8):</p> <ul style="list-style-type: none"> <input type="checkbox"/> Adaptive/Fuzzy Logic HVAC Control <input type="checkbox"/> Building Automation System <input type="checkbox"/> Complete/Retro Commissioning <input type="checkbox"/> Finite State Machine Control <input type="checkbox"/> Personal Thermostat (e.g. Ring Thermostat) <input type="checkbox"/> Regular Maintenance <input type="checkbox"/> System/Component Performance Diagnostics <input type="checkbox"/> Zonal Ventilation/Control

In the “Round of 55”, the effort focused on improving the quality of the estimates of energy savings potential, cost, and identification of non-economic barriers facing each technology option. This process included review and critical analysis of additional technical literature and discussions with industry experts, as well as independent performance and cost analyses where needed.

Appendix A contains the results of analyses for the 40 options not selected for more refined evaluation. A number of the 40 options (e.g., two-speed motors) have substantial energy savings potential but were not studied further because the energy savings potential, economics, and barriers were generally well understood and further study (in the context of this report) would not have not resulted in further clarification.

3.4 Selection of the 15 Options for More Refined Evaluation (Step 5)

Selection of the 15 options for more refined evaluation was based on estimates of the technical energy savings potential and economic attractiveness (e.g., simple payback period) developed for each of the 55 options, as well as the barriers to commercialization faced by each option. In addition, the selections took into account the value of further study by TIAX, i.e., how much would additional study within the scope of this project contribute to the understanding of the energy savings potential, economics, non-economic barriers, and appropriate “next steps” for each technology. After deliberation, 15 options were selected for more refined evaluation (see Table 3-2).

Table 3-2: The 15 Technology Options Selected for Further Evaluation

Technology Option	Reason for Further Evaluation
Adaptive and Fuzzy Logic Control	Energy savings potential; range of application
Brushless DC Motors	Cost in smaller sizes; potential integration with solar PV
Dedicated Outdoor Air Systems	Energy savings potential and cost impact
Displacement Ventilation	Energy savings potential and cost
Enthalpy/Energy Recovery Heat Exchangers for Ventilation	Cost refinement; cost reductions afforded by advanced materials
Heat Pumps for Cold Climates	Novel concepts (e.g., CO ₂ heat pumps)
Improved Duct Sealing	Improvements in current design/installation practice
Liquid Desiccant Air Conditioner	Feasible performance levels and energy savings potential
Microchannel Heat Exchangers	Cost
Microenvironments (Includes Occupancy-Based Sensors)	Energy savings potential; future cost reduction, performance improvement
Novel Cool Storage Concepts	Peak condition savings (generation efficiency, T&D losses); benefits of smaller-scale storage
Radiant Ceiling Cooling / Chilled Beam	Ventilation energy savings potential; cost premium
Smaller Centrifugal Compressors	Evaluation of cost and performance points; different refrigerants
System / Component Diagnostics	Refinement of energy savings and implementation costs
Variable Refrigerant Volume/Flow	Energy savings potential; marginal cost

Section 4 contains summaries of the investigations for each of the 15 technology options, paying particular attention to the performance (technical energy savings potential), cost (economics), and market barriers facing each option.

3.5 More Refined Evaluation of 15 Options (Step 6)

Further analysis for the 15 technology options addressed issues and questions specific to each technology. For each option, the more refined evaluation attempted to home in on key information needed to provide a clearer image of the technology’s technical and market-based energy saving potential. This ranged from development of analytical models to improve energy savings estimates to gathering additional cost information related to the technology option. The evaluation also focused on information that could be developed within the context of this project, i.e., a simple building model using binned weather and building load data could be created to evaluate Heat Pumps for Cold Climates, but a full-blown DOE-2 simulation was outside the scope of the current project. Typically, refined analysis included further consideration of the technical literature, often to inform analytical modeling and gathering of additional cost information.

4 THE 15 TECHNOLOGY OPTIONS SELECTED FOR MORE REFINED STUDY

Section 4 of the report presents the analyses for the 15 options selected for more refined study (see Table 4-1), with each sub-section containing the results for a single technology option.

Table 4-1: Energy Savings Potential Summary for 15 Options

Technology Option	Technology Status	Technical Energy Savings Potential (quads)
Adaptive/Fuzzy Logic Controls	New	0.23
Dedicated Outdoor Air Systems	Current	0.45
Displacement Ventilation	Current	0.20
Electronically Commutated Permanent Magnet Motors	Current	0.15
Enthalpy/Energy Recovery Heat Exchangers for Ventilation	Current	0.55
Heat Pumps for Cold Climates (Zero-Degree Heat Pump)	Advanced	0.1
Improved Duct Sealing	Current/New	0.23
Liquid Desiccant Air Conditioners	Advanced	0.2 / 0.06 ¹²
Microenvironments / Occupancy-Based Control	Current	0.07
Microchannel Heat Exchanger	New	0.11
Novel Cool Storage	Current	0.2 / 0.03 ¹³
Radiant Ceiling Cooling / Chilled Beam	Current	0.6
Smaller Centrifugal Compressors	Advanced	0.15
System/Component Diagnostics	New	0.45
Variable Refrigerant Volume/Flow	Current	0.3

It is important to note that the energy savings potentials of different technologies are not additive, as savings realized for by technology will, to varying degrees, decrease and/or preclude energy savings achievable by other technologies.

Each write-up follows the same basic format:

- Technology Option Status Summary;
- Technology Key Metrics Summary Table;
- Background Information (How it functions in an HVAC system, how it could save energy);
- Performance (energy savings) Potential Summary and Discussion;
- Cost (economic) Summary and Discussion;
- Barriers to Commercialization;
- Technology Development “Next Steps”;

¹² The two energy savings estimates presented for Liquid Desiccant Air Conditioners are for use as a DOAS and relative to a conventional DOAS, respectively.

¹³ The two energy savings estimates presented for the Novel Cool Storage option are for all packaged and chiller systems and only water-cooled chillers, respectively

- References.

Each technology option summary includes the “Relevant Primary Energy Consumption”, which equals the amount of energy consumed by commercial HVAC systems to which the technology option could be applied. Tables 4-2, 4-3, and 4-4 present breakdowns of commercial HVAC energy consumption by equipment type for cooling, heating, and parasitic equipment, respectively.

Table 4-2: Commercial Building Cooling Primary Energy Consumption Breakdown (from ADL, 2001)

Component	Total Energy Use (quads)	Percent
Rotary Screw Chillers	0.037	2.7%
Reciprocating Chillers	0.17	12.4%
Absorption Chillers	0.022	1.7%
Centrifugal Chillers	0.19	13.7%
Heat Pump	0.092	6.8%
PTAC	0.038	2.8%
Unitary A/C (Rooftops)	0.74	55%
RACs	0.074	5.5%
<i>Totals</i>	<i>1.4</i>	<i>100%</i>

Table 4-3: Commercial Building Heating Primary Energy Consumption Breakdown (from ADL, 2001)

Component	Total Energy Use (quads)	Percent
Furnaces	0.34	20%
<i>Gas</i>	<i>0.21</i>	<i>12.4%</i>
<i>Oil</i>	<i>0.054</i>	<i>3.2%</i>
<i>Electric</i>	<i>0.073</i>	<i>4.3%</i>
Boilers	0.36	21%
<i>Gas</i>	<i>0.23</i>	<i>13.7%</i>
<i>Oil</i>	<i>0.13</i>	<i>7.6%</i>
Unit Heaters	0.31	18%
<i>Gas</i>	<i>0.15</i>	<i>8.6%</i>
<i>Electric</i>	<i>0.16</i>	<i>9.5%</i>
Heat Pumps	0.107	6.3%
<i>Ducted Heat Pumps</i>	<i>0.078</i>	<i>4.5%</i>
<i>PTHP, WLHP</i>	<i>0.029</i>	<i>1.7%</i>
Individual Space Heaters	0.039	2.3%
<i>Infra-Red Radiant</i>	<i>0.011</i>	<i>0.6%</i>
<i>Electric Baseboard</i>	<i>0.028</i>	<i>1.7%</i>
Packaged Units	0.44	26%
<i>Gas</i>	<i>0.37</i>	<i>22%</i>
<i>Electric</i>	<i>0.068</i>	<i>4.0%</i>
District Heating	0.11	6.5%
<i>Total</i>	<i>1.7</i>	<i>100%</i>

Table 4-4: Commercial Building Parasitic Primary Energy Consumption Breakdown (from ADL, 1999)

Component	Total Energy Use (quads)	Percent
Supply/Return Fans	0.74	51%
Chilled Water Pumps	0.029	2.0%
Condenser Water Pumps	0.027	1.8%
Heating Water Pumps	0.071	4.8%

Cooling Tower Fans	0.016	1.1%
Condenser Fans	0.072	4.9%
Fan-Powered Terminal Boxes	0.023	1.6%
Exhaust Fans	0.49	33%
<i>Total</i>	1.5	100%

In many instances, the simple payback period, SPP, was used to quantify the economics of a technology. It equals the cost of the energy savings afforded by the technology, C_{Esave} , divided by the incremental premium of the energy efficiency measure, which is the difference between the cost of the default technology, C_{def} , and that of the technology option, C_{opt} :

$$SPP = \frac{C_{Esave}}{C_{def} - C_{opt}} .$$

Unless stated otherwise, all calculations assumed that electricity in the commercial buildings sector cost \$0.07/kWh and that gas cost \$5.50/MMBtu¹⁴. De Canio (1994, from Hawken et al., 1999) found that about 80% of American firms that use some other method than first cost to study energy efficiency investments employed SPP, and that the median threshold SPP was 1.9 years. Hawken et al. (1999) note that this corresponds to a 71% real after-tax rate return on investment (ROI), far in excess of the standard 25% hurdle ROI set for many corporate internal investments.

4.1 Adaptive and Fuzzy Logic Control

4.1.1 Summary

Adaptive and Fuzzy control algorithms improve upon classic control approaches by allowing for much better flexibility to respond to HVAC control challenges, particularly for systems operating over a wide range of system operating states. They can potentially save energy by enabling control operations not feasible with classic controls. Perhaps more importantly, they can help to assure adequate control in situations in which the time is not taken to properly set up conventional controls. While the potential benefits of such advanced controls have been reported in the technical literature, the need for and benefits of these approaches is not always clear on the level of building operators and owners. Much equipment uses conventional non-electronic control and would first require conversion to electronic control to allow implementation of fuzzy or adaptive control. Technicians also require more training to properly troubleshoot electronic control systems. There is a place for adaptive and fuzzy control in the portfolio of energy saving options, but actual savings to be expected from increasing their use has yet to be accurately quantified.

¹⁴ These reflect a rough average of the prices paid by commercial end users for electricity and gas circa 2000, based on data provided by the EIA: <http://www.eia.doe.gov/cneaf/electricity/epm/epmt53p1.html> and http://www.eia.doe.gov/oil_gas/natural_gas/info_glance/sector.html.

Table 4-5: Summary of Adaptive/Fuzzy Control Characteristics

Characteristic	Result	Comments
Technical Maturity	New	Significant R&D work has been done, but adoption of Adaptive or Fuzzy Logic has been rare in mainstream commercial HVAC
Systems Impacted by Technology	All HVAC Systems	
Readily Retrofit into Existing Equipment/Buildings?	Yes	
Relevant Primary Energy Consumption (quads)	4.5	
Technical Energy Savings Potential (quads)	0.23	Based on very rough 5% energy savings estimate applied to all HVAC systems
Approximate Simple Payback Period	Varies	The wide range of implementation scenarios for fuzzy and adaptive control has a broad range of economic attractiveness. Equipment already incorporating electronic control can much more easily be programmed for fuzzy or adaptive control than equipment currently using conventional controls.
Non-Energy Benefits	Improved occupant comfort	Anticipation of future (e.g., next hour) HVAC needs for improved control. "Learning" of system characteristics to improve control.
Notable Developers/Manufacturers of Technology	Major Control Vendors, i.e. Honeywell, Johnson Controls, Invensys, etc.	
Peak Demand Reduction	Yes	
Most Promising Applications	HVAC Systems with a wide range of important energy-intensive operating conditions.	
Technology "Next Steps"	<ul style="list-style-type: none"> • Properly Identify Energy Loss Associated with Inadequate Operation with Conventional Control • Demonstration • Development of Test Standards to Quantify/Demonstrate Benefits • Monitor Implementation by Control Vendors 	

4.1.2 Background

Adaptive and Fuzzy Control represents a range of control techniques that can provide better control than conventional HVAC system controls.

Fuzzy Control is based on establishing a set of "verbal" rules for system operation such as "If the temperature is cold increase the valve opening". Rules such as these are consistent with the way people would talk about controlling systems, but they require interface to their input and output variables. The interface to input variables is called "fuzzification" and the interface to the output variables is called "defuzzification". The algorithm converts an input variable, such as temperature, into a series of functions describing the degree to which the temperature belongs to a set of values such as {cold, cool, comfortable, warm, hot}. Fuzzy logic theory is then used to determine the appropriate output for the given set of control rules. The increase in the valve setting may have fuzzy values such as {very negative, slightly negative, zero, positive, very positive}, and application of the control rules assigns a degree of suitability for each of these possible actions. The "defuzzification" process then converts the fuzzy values into an appropriate change in the output value, for instance in the position of the valve.

Simple forms of Adaptive Control are based on classical PID (Proportional-Integral-Differential) control, with capability for adjustment of the control coefficients (tuning) in real time based on the system behavior. More complex control approaches can involve other strategies for control improvement such as the following:

- 1) Adjustment of control based on predictions of system input parameters, such as prediction of weather which will affect future HVAC needs.
- 2) Controls that learn desired operating patterns based on inputs from users or system dynamics.

Energy savings can be achieved using these advanced control approaches in the following ways:

- 1) Control stability may not be guaranteed for conventional on/off or even for classic fixed-coefficient PID control for systems experiencing a wide range of operating conditions. For instance, a thermostat that provides very good temperature control on a cold winter day may cause the space temperature to overshoot significantly on a moderately cool day or during morning warmup.
- 2) Tuning of controllers, required for classic PID controllers, is often not done or not done properly. Adaptive control algorithms have been developed which eliminate the need for this step. One example is Pattern Recognition Adaptive Control (PRAC; see Seem, 1998 for more information).
- 3) Real-time optimization of operating parameters can result in energy savings. For instance, minimization of input power for a large rooftop unit may require use of all condenser fans in high ambient temperatures but use of fewer fans in moderate ambient temperatures. A simple reset strategy based on outdoor air temperature could be employed but may not be as efficient as real-time optimization because the optimization may depend also on evaporator conditions.
- 4) HVAC system operating strategy may not easily be translated into the mathematical definition required for PID control. For instance, a control system could pass on a call for heating if the space is not too cold and the occupancy period is about to end. Such a concept can much more easily be implemented using Fuzzy Control.
- 5) Energy use can be reduced through advanced knowledge of weather conditions. For instance, if a day in early spring will be much warmer than normal, initiation of preheating prior to occupancy will both waste energy and reduce comfort. An example of a control approach incorporating weather information is presented in Johansson (2000).
- 6) Thermostats that learn from building occupancy patterns can optimize delivery of heating and cooling (Boisvert and Rubio, 1999).

These are just a few examples of how advanced controls approaches can be used to save energy. There are certainly many other areas where an increase in control sophistication can save energy. For each of these areas, there may be more than one way to implement an improved strategy. In other words, it is not clear that Fuzzy Control, or any of the other control approaches, would be the best approach across the board. The range of equipment

categories, system configurations, and operating scenarios make a one-technique-fits-all approach all but impossible.

As part of this study, some investigation was done to assess whether fuzzy control products are generally available for HVAC system control. The search did not reveal a large number of such products. Electronic expansion valves and related electronic valves manufactured by Sporlan (hot gas bypass, evaporator pressure regulators, etc.) use classic PID, or simply PI control to obtain good results (Dolin, 2002). This suggests that the benefits of fuzzy control for expansion devices (Jolly et al., 2000) may not apply for typical commercial HVAC applications. Robertshaw's Slimzone Premier DSL-520P Zone Thermostat uses "an adaptive control routine, based on fuzzy logic"¹⁵. The control calculates the load of the room it is in to optimize control outputs. Web searches on websites of major controls vendors for control products incorporating fuzzy control did not identify any other fuzzy HVAC controls.

4.1.3 Performance

Claims of energy savings resulting from Adaptive or Fuzzy Control vary widely. The literature reports energy savings in a number of applications, but the range of savings potential associated with advanced controls is not very well understood in general. A rough preliminary estimate of the national HVAC energy savings potential is 5%.

Some of the HVAC system performance issues that adaptive or fuzzy control could help to resolve, e.g., failure to tune PID coefficients, would also be identified if building commissioning were done or if a system diagnostic capability were integrated with the equipment controls or building energy management system.

4.1.4 Cost

Equipment changes associated with Adaptive/Fuzzy Control that impact cost vary greatly depending on the application and the control approach utilized. Possible changes required to implement such control are as follows:

- 1) Use of a microprocessor rather than electromechanical control components.
- 2) Use of a larger microprocessor than would be used for simpler control approaches.
- 3) Additional sensors.
- 4) Communications interfaces (for instance, for receiving weather data with an internet connection).
- 5) Additional control output components, such as contactors or damper motors, which would provide some control output function that would not be used with conventional equipment using conventional control.
- 6) Modified HVAC equipment may be used to allow implementation of a control strategy that cannot be implemented with conventional controls. For instance, an electronic expansion valve would be required to provide Fuzzy Control of superheat.

¹⁵ From product literature. Available at: <http://www.maplechase.com/products/ControlPanels.htm> .

4.1.5 Perceived Barriers to Market Adoption of Technology

Adaptive/Fuzzy Controls are often discussed and marketed in general terms that “sound good” but do not provide a concrete understanding of how they save energy. Similarly, specific examples of energy waste that can be eliminated through the use of advanced controls are not well documented. In addition, use of advanced controls can be complicated, making difficult the job of convincing end-users that energy can be saved. The more complicated nature of these controls makes installation, troubleshooting, and service more difficult for contractors or technicians accustomed to conventional equipment. The diverse range of ways in which Adaptive/Fuzzy Controls provide HVAC system and equipment savings makes this “technology” difficult to understand and manage, for building owners and organizations such as energy service providers as well as equipment developers.

4.1.6 Technology Development “Next Steps”

- Continued development of specific controls concepts which are well understood and whose energy benefit is accepted.
- Development of a better understanding of ways in which conventional controls provide less-than-optimum system and equipment performance and how Adaptive/Fuzzy Control can improve on this.

4.1.7 References

1. Seem, J.E., 1998, “A New Pattern Recognition Adaptive Controller with Application to HVAC Systems”, *Automatica*, Vol. 34, No. 8, pp. 969-982.
2. Johansson, M., 2000, “Local Weather Forecasts Control the HVAC System in Buildings”, *CADDET Energy Efficiency*, March. Available at: <http://www.ieaetec.com/techpdf/r419.pdf> .
3. Dolin, B., 2002, Personal Communication, Sporlan Valve Company, May.
4. Jolly, P.G., C.P.Tso, P.K.Chia, and Y.W.Wong, 2000, “Intelligent Control to Reduce Superheat Hunting and Optimize Evaporator Performance in Container Refrigeration”, *International Journal of HVAC&R Research*, vol. 6, no. 3, July.
5. Boisvert, A., and R.G.Rubio, 1999, “Architecture for Intelligent Thermostats That Learn from Occupants’ Behavior”, *ASHRAE Transactions*, Vol. 105, Pt. 1.

4.2 Dedicated Outdoor Air Systems (DOAS)

4.2.1 Summary

Dedicated Outdoor Air Systems (DOAS) condition the outdoor ventilation make-up air separately from the return air from the conditioned space. This approach to handling ventilation make-up air results in superior humidity control by dealing with the primary source of humidity in most buildings – ambient humidity carried in by the ventilation air – directly at its source. When the DOAS removes enough extra moisture from the make-up air to handle the building interior load, energy savings can be obtained by running the separate, sensible cooling only, interior cooling system at higher evaporating temperature, improving the energy efficiency. Further energy savings are realized by providing only the

amount of ventilation air necessary and by using enthalpy recovery for the building exhaust air to pre-cool the make-up air.

Table 4-6: Summary of Dedicated Outdoor Air Systems Characteristics

Characteristic	Result	Comments
Technical Maturity	Current	
Systems Impacted by Technology	All HVAC equipment	Heating, cooling, and ventilation systems
Readily Retrofit into Existing Equipment/Buildings?	Depends	A DOAS needs many more duct connections
Relevant Primary Energy Consumption (quads)	4.0 quads	All non-individual cooling and ventilation systems; OA heating energy
Technical Energy Savings Potential (quads)	0.4 to 0.5 quads	<ul style="list-style-type: none"> • 10% reduction in heating • 17% reduction in cooling • Approximately no net impact on ventilation energy
Approximate Simple Payback Period	Potentially immediate	Potentially lower first cost (in new construction and major renovation); includes benefit of additional rentable space
Non-Energy Benefits	Improved humidity control and occupant comfort	By delivering more appropriate space conditioning to different zones, zonal control decreases temperature swings, improving occupant comfort and possibly increasing productivity. In applications with small indoor humidity loads and low infiltration, a DOAS allows de-coupling of the latent and sensible load management by managing the OA (primary) humidity source separately.
Notable Developers/Manufacturers of Technology	Several	Penn State University, EPRI, McClure Engineering
Peak Demand Reduction	Yes	Yes, by ensuring only that occupied areas receive space conditioning during peak demand periods; a DOAS further reduces peak demand by decreasing OA cooling loads, which approach maximum values during peak demand periods.
Most Promising Applications	Buildings with large amounts of variably occupied space, such as office buildings, hospitals or schools. DOAS systems provide larger benefits in regions where the OA conditioning burden is larger.	
Technology “Next Steps”	Demonstration of energy saving and superior humidity control, design software.	

4.2.2 Background

It is common practice in commercial building air conditioning to combine ventilation make up air with return air from the building, condition (cool or heat) this air as needed, and distribute the conditioned air to the interior space, with or without zoned temperature control. Dedicated Outdoor Air Systems (DOAS) condition the outdoor ventilation make-up air separately from the return air from the conditioned space (see Figure 4-1).

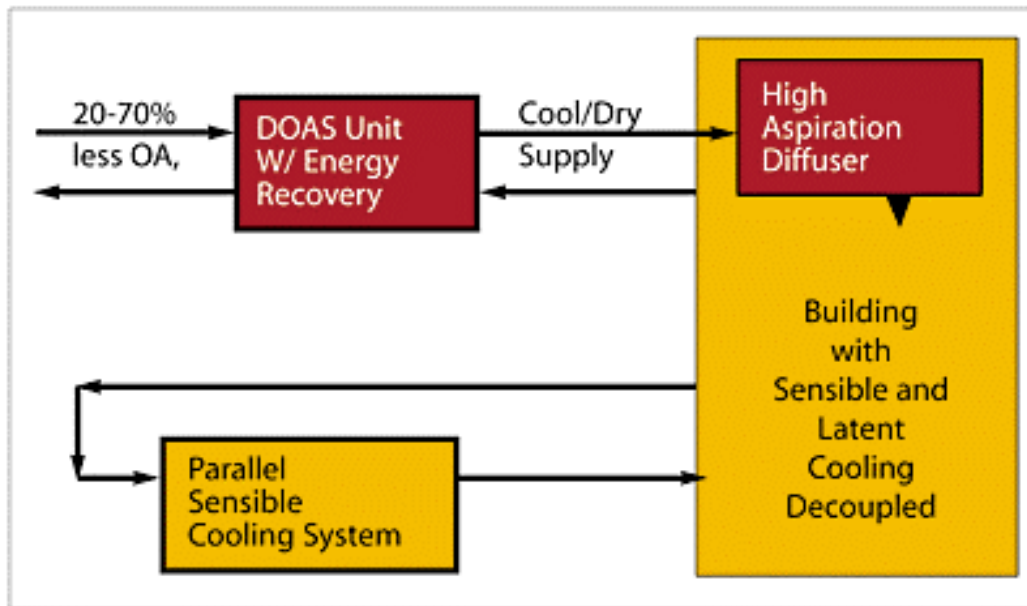

Figure 4-1: Schematic of a Dedicated Outdoor Air System (from Mumma, 2001a)

This approach to handling ventilation make-up air has received considerable attention in past several years, as indicated by the number of trade journal articles cited in the bibliography. The impetus for this attention has been the growing realization of the penalties and difficulties involved in meeting ASHRAE Standard 62 (*Ventilation for Acceptable Indoor Air Quality*) requirements throughout the conditioned space of a commercial building, with effective humidity control, particularly in the context of energy efficient approaches such as variable air volume. The difficulty of achieving good ventilation performance with a VAV system is illustrated in several references (Stanke, 1998; Kettler, 1998; Shelquist and Amborn, 2001; Chamberlin et al., 1999). Each presents elaborate schemes for controlling the distribution of ventilation make-up air and ensuring that the total and local supply of make up air meets ASHRAE 62 requirements as the total air flow in a VAV system is varied in response to the cooling load.

It is also recognized that considerable energy must be expended to condition make-up air, particularly when it is combined, without preconditioning, with the return air from the conditioned space. Demand controlled ventilation (DCV) is one approach to limiting the energy impact. DCV uses sensors that measure the carbon dioxide concentration as a proxy for actual occupancy, and vary the ventilation flow rate in proportion to occupancy, maintaining constant (800 - 1200 ppm) concentration. However a fundamental limitation of this approach that is increasingly being recognized is that ventilation dilutes and removes a variety of indoor air pollutants, many of which are not directly related to the human occupancy level. In fact, the current ASHRAE 62 ventilation rates were established, at least in part, on the basis of considerable empirical evidence (Persily, 1999) that buildings with the current ASHRAE 62 ventilation rates (based on nominal occupancy) typically do not

experience major IAQ related problems, while buildings with lesser amounts frequently do experience these problems. Consequently, it is desirable to have a ventilation scheme that allows full ventilation flows to be maintained without incurring other penalties. In practice, vapor cycle air conditioning systems are often unable to maintain comfortable (i.e., low enough) humidity levels in the conditioned space, when humid ventilation make-up air is mixed with building return air prior to the cooling coil.

Handling the treatment and distribution of ventilation make-up air and of return air from the occupied space with separate, parallel systems offers a number of potential advantages over conventional VAV systems that help to overcome the problems discussed above. Many of these advantages directly result in significant energy savings:

- The ventilation make-up air system can be sized and operated to provide the ventilation air flow rate required by code (e.g., ASHRAE Std 62) to provide acceptable indoor air quality and provide this flow rate regardless of the interior temperature, without any need to oversize the ventilation rate. The ventilation rate can be constant, or it can be varied based on the building operating/occupancy schedule or in response to the actual occupancy (on a real time basis). Moreover, a DOAS allows easy verification that the system supplied the minimum OA quantities to different portions of a building. Energy recovery heat exchange between the make-up air and exhaust is readily implemented in this configuration, reducing peak cooling and heating loads to condition make-up air. This is in marked contrast to conventional VAV systems, where OA delivery rates can vary significantly as supply air rates change and introduce significant system complexity (Chamberlin et al., 1999).
- The predominant humidity load in most commercial building in most climate areas is the humidity brought in with the ventilation make-up air (in hot weather). Consequently, the entire humidity load for the building can be handled efficiently by separately conditioning the make-up air so that excess ambient humidity is removed (along with additional capacity to cover internal moisture sources).
- With the ventilation make-up air separately conditioned, with the entire building humidity load handled in the process, the recirculated indoor air conditioning system can be operated to maintain temperature control. Because this is intended for sensible cooling only, the cooling can be operated at a higher than normal temperature (approximately 55°F evaporating temperature vs. 40°F to 45°F, typically) preventing moisture condensation and increasing the COP of the compressor. In addition to providing independent temperature and humidity control, this is an ideal situation for VAV. The conditioned air flow rate is varied in proportion to the net cooling or heating load, saving significant amounts of blower power during the large proportion of the year when full heating or cooling capacity is not required. Meanwhile the parallel ventilation make-up air system continues to deliver the appropriate amount of air for IAQ purposes. Note that this applies to both chilled water based systems and to DX systems.

- Alternatively, with the ventilation make-up air separately conditioned, with the entire building humidity load handled in the process, other energy-efficient, sensible only cooling approaches, such as radiant ceiling cooling (see separate discussion) can be employed.

These advantages can be realized in either a single-zone or a multi-zoned HVAC system layout. In the single zone case, the preceding advantages apply. Zonal HVAC Control systems divide a building into multiple areas, or zones, and actively control the environment in each zone per the need of each zone. Typically, the HVAC system designer will delineate the zones based upon differences in location, occupancy, and purpose. For instance, a single-story office building might have seven zones, three for independent office areas, two tied into conference rooms, one for an eating area, and another for building services. Separate VAV terminals controlled by occupancy sensors (e.g., CO₂ sensors) could heat, cool, and ventilate by ‘zone’, a pre-determined area of space in a building, as determined by zone occupancy. Typically, zones average ~900ft², ranging from 500 ft² and up (Griep, 2001). In unitary equipment, multizone packaged equipment is usually limited to about 12 zones (ASHRAE, 1996). DOAS deliver outdoor air directly to specific rooms/small zones, avoiding over-delivery of OA caused by larger (e.g., central) systems (see, for example, Mumma, 2001a).

The zonal approach delivers heating, cooling and ventilation to areas as need, reducing the unneeded conditioning of unoccupied zones and over-heating or over-cooling of occupied zones. Dedicated Outdoor Air Systems (DOAS) can realize further efficiency gains by greatly reducing the introduction of excess outdoor air (OA) required to achieve minimum OA levels in a multi-zone system, thus reducing the amount of OA air conditioning (both heating and cooling).

4.2.3 Performance

DOAS achieves energy savings via three primary factors – optimal use of the ventilation air provided (allowing compliance with ASHRAE 62 with the minimum quantity of outdoor air), ready use of enthalpy recovery to precool the outdoor air, and allowing the interior load to be handled at higher refrigerant temperature and COP. When the interior load is handled with chilled ceiling panels, thermal distribution parasitic power is reduced significantly as well (see Section 4.12 for a discussion of Radiant Cooling + DOAS)¹⁶.

The combination of a DOAS with a sensible cooling only VAV system saves energy by reducing total ventilation air flow and by handling sensible cooling loads more efficiently. In a DOAS, ASHRAE 62 ventilation requirements can be met with less ventilation air flow due to the inherent precision of the DOAS in delivering required ventilation flows in the aggregate and in the individual zones in the building. In space cooling mode, energy saving include the benefit of higher chilled water temperature for the sensible part of the load and

¹⁶ Analysis by TIAx compared air moving energy savings for same sized ducts (baseline VAV vs. DOAS) and for ducts that were downsized in proportion to the reduced design air flow rate of the DOAS system. When the duct cross section remained constant, annual air moving power reductions in excess of 80% occur. When the DOAS duct cross section was reduced to reflect the required OA, air moving energy saving range from nil (moderate climate) to 30% (warm climate). This result indicates that the optimum duct cross section for a DOAS combined with radiant panels is larger than a simple scale down of design air flow rates – reflecting the constant flow use of these ducts by the DOAS.

reduced ventilation flows to be cooled. In space heating mode, energy is saved as a result of the reduced ventilation air flow allowed by the inherent precision of the DOAS in delivering required ventilation flows in the aggregate and in the individual zones in the building. TIAX analyses using binned building load and weather data for office buildings with VAV systems show that typically 50 to 60% of the space heating load is due to heating outside air. The DOAS allows outside air to be reduced by approximately 20%¹⁷, resulting in space heating energy savings on the order of 10% (see Table 4-7).

Table 4-7: Energy Savings of DOAS versus Conventional VAV

Category	Percent Energy Saved	Comments
Space Heating	8-12%	<ul style="list-style-type: none"> • OA ~50% of heating load • 20% reduction in OA
Space Cooling	15% - 20%	<ul style="list-style-type: none"> • OA ~ 25% of cooling load • 20% reduction in OA • For internal loads, ~20% COP increase (11°F evaporator temperature rise)
Ventilation (air moving) power	0%	<ul style="list-style-type: none"> • Reduction of over-ventilation offset by ~CAV function of OA unit

In addition to energy savings, DOAS systems provide superior indoor humidity control over a wide range of outdoor temperature and humidity levels. This can prevent mold growth and promote healthier indoor conditions. On the other hand, in contrast to a conventional VAV system, DOAS generally precludes economizer operation at levels above and beyond those needed to satisfy OA requirements, as the DOAS would most likely not include additional ventilation capacity.

4.2.4 Cost

A general perception exists that replacing one single purpose system with two parallel systems – the DOAS and the interior thermal load systems¹⁸ – will result in increased installed equipment costs due to installation of additional (more) equipment. In new construction or major renovations this is not necessarily accurate. Mumma (2001d) lists no fewer than nine categories of building mechanical system and overall building costs that are reduced by using a separate DOAS as described in this section – for example, reduced chiller (or DX system) tonnage, reduced chilled and condenser water pump capacity, reduced ductwork size and cross-section, smaller air distribution plenums and terminal boxes, AH- size reduction, reduced electrical service in line with reduced chiller, blower and pump power consumption, less “rentable” space taken up by mechanical equipment and reduced total floor height. In the case study of the 186,000 ft² office building (referred to above), the combination of DOAS and chilled ceiling (for interior sensible loads) reduced total first cost by \$2/ft², compared to a “conventional” all-air VAV system. In effect, the potential exists for DOAS to be implemented with no first cost penalty, with energy cost

¹⁷ Rough TIAX estimate; in some cases, it could be significantly higher, e.g., a hypothetical scenario explored by Mumma (2001a) found that the VAV system needed to take in 70% more outdoor air than required to satisfy ASHRAE 62.

¹⁸ In principle, the DOAS and interior thermal load cooling systems could share a chilled water loop, with the cooler water conditioning the OA and then flowing to the interior thermal load system. This design, however, would negate the energy savings accrued from using a higher evaporator temperature to condition the interior thermal loads.

savings and the benefits of drastically improved humidity control and improved occupant productivity providing an instant payback and continuing savings.

4.2.5 Perceived Barriers to Market Adoption of Technology

The preceding discussion of cost notwithstanding, the widespread perception exists that HVAC systems based on a DOAS have higher first costs than conventional systems. This perception is a symptom/result of the relatively recent introduction of the approach and the unfamiliarity of HVAC designers and contractors with DOAS. In general, DOAS goes against current HVAC practice.

To the extent that use of DOAS is viewed as a means to enhancing the performance of zoned, VAV, and/or DCV system designs, first cost is also an issue, as well as the contractor's willingness to sell and estimate costs for zoning jobs. Tally (2001) reflected the belief that some people believe that zoning cannot be extended appreciably beyond its present application.

4.2.6 Technology Development "Next Steps"

The demonstration of energy savings and superior performance in managing indoor humidity levels in actual buildings is a priority toward widespread acceptance of DOAS. A modestly-sized office building with a 25-ton design cooling load (approximately 10,000 to 12,000 ft²) would be a suitable site for an effective cost demonstration. To demonstrate the benefit of superior humidity control, along with energy savings, the demonstration should take place in a humid climate.

Assuming that the demonstration succeeds, the development of a simple yet effective model¹⁹ that enables HVAC designers to predict energy cost savings and overall building cost savings of DOAS would increase the ability of system designers to consider DOAS as a design option, as well as facilitating ESCO implementation. Ideally, such a tool would also allow system designers to determine the best option (relative to energy and economics) for the parallel sensible cooling system, either sensible only VAV, radiant ceiling panels, or another alternative.

4.2.7 References

- Chamberlin, G.A., Maki, K.S., Li, Z., Schwenk, D.M., and Christianson, L.L., 1999, "VAV Systems and Outdoor Air", *ASHRAE Journal*, October, vol. 41, no. 10, pp. 39-47
- Coad, W.J., 1999, "Conditioning Ventilation Air for Improved Performance and Air quality," *Heating Piping and Air Conditioning*, September, pp. 49-56.
- Kettler, J.P., 1998, "Controlling Minimum Ventilation Volume in VAV Systems," *ASHRAE Journal*, May, pp. 45-50.

¹⁹ Presently, the DOE program EnergyPlus can include DOAS (more information available at: http://www.eren.doe.gov/buildings/energy_tools/energyplus/).

Khattar, M. K. and Brandenmuehl, M. J., 2002, “Separating the V in HVAC: A dual Path Approach,” *ASHRAE Journal*, May, pp. 37-43.

Mumma, S.A., 2001a, “Fresh Thinking: Dedicated Outdoor Air Systems”, *Engineered Systems*, May, pp. 54 –60. Available at: <http://www.doas.psu.edu/papers.html> .

Mumma, S.A., 2001b, “Designing Dedicated Outdoor Air Systems,” *ASHRAE Journal*, May, pp. 28-31. Available at: <http://www.doas.psu.edu/papers.html> .

Mumma, S.A., 2001c, “Dedicated Outdoor Air in Parallel with Chilled Ceiling System”, *Engineered Systems*, November, pp. 56–66. Available at: <http://www.doas.psu.edu/papers.html> .

Mumma, S.A., 2001d, “Ceiling Panel Cooling Systems,” *ASHRAE Journal*, November, pp. 28-32. Available at: <http://www.doas.psu.edu/papers.html> .

Mumma, S.A., 2002, “Is CO₂ Demand-Controlled Ventilation the Answer?,” *Engineered Systems*, May, pp. 66–78.

Persily, A., 1999, “Rationale for Ventilation Rate Requirements in ASHRAE Standard 62-1999 and in Potential Revisions to the Standard”, *ASTM Symposium – Air Quality and Comfort in Airliner Cabins*, New Orleans, October.

Shelquist, P. and Amborn, R., 2001, “Ventilation Control Strategies,” *ASHRAE Journal*, September, pp. 30-35.

Stanke, D.A., 1998, “Ventilation Where It’s Needed,” *ASHRAE Journal*, October, pp. 39-47.

Tally G., 2001, Personal Communication, California Economizer.

Turner, W.A., 1999, Advanced Ventilation Design for Commercial, Industrial and Institutional Facilities,” *Heating Piping and Air Conditioning*, October, pp. 61-66.

4.3 Displacement Ventilation

4.3.1 Summary

Although it has a strong presence in Europe, displacement ventilation remains relatively unknown to building designers and consulting HVAC engineers in the United States. Energy saving potentials and simple payback periods vary substantively for different buildings, system designs, and climates. Improved indoor air quality is a defining property of displacement ventilation and is strongly responsible for its popularity in Europe. In the United States, improved awareness about the benefits of displacement ventilation is necessary to increase its market share and realize the energy savings potential.

Table 4-8: Summary of Displacement Ventilation Characteristics

Characteristic	Result	Comments
Technical Maturity	Current	Most commonly deployed in Northern Europe
Systems Impacted by Technology	Central and packaged HVAC systems	
Readily Retrofit into Existing Equipment/Buildings?	No	Displacement ventilation typically requires restructuring of ductwork and larger diffusers (sometimes incorporated into a raised floor) to provide low-velocity air at sufficient flow rates. Supply and return fans typically must be replaced.
Relevant Primary Energy Consumption (quads)	1.9	Cooling energy and supply/return fan loads associated with central and packaged HVAC systems.
Technical Energy Savings Potential (quads)	0.20	Based on a 0.46 quad cooling energy reduction ²⁰ , coupled with a 0.26 supply and return fan energy increase.
Approximate Simple Payback Period	3.5 to 20 years	Highly dependent on climate, with warmer climates paying back more quickly. Most climates would see 5 to 10-year payback periods.
Non-Energy Benefits	Improved Indoor Air Quality	Stratified air traps thermally-linked pollutants above the occupied zone (i.e. above breathing level)
Notable Developers/Manufacturers of Technology	UC Berkley, MIT, International Air Technologies, European Architecture firms.	UC Berkley: Center for the Built Environment MIT: Building Technology Group
Peak Demand Reduction	Yes	From a reduction in peak cooling power draw
Most Promising Applications	Buildings with high ceilings that have moderate peak cooling load densities (<13 Btu/hr-ft ²), large annual cooling energy consumption, and require small quantities of fresh air with high air quality, e.g., offices, public buildings. Within a building, HVAC zones in “core” areas are attractive for displacement ventilation because they have moderate peak cooling loads relative to window areas, but consistent year-round cooling loads.	
Technology “Next Steps”	Demonstration projects documenting energy savings while complying with building codes (perhaps starting with publication of case studies for existing buildings in Europe).	

4.3.2 Background

Traditional “mixing” ventilation uses a turbulent jet of fresh air to mix and dilute any stale polluted air and maintain thermal comfort conditions in a building space. In contrast, displacement ventilation uses a low-velocity stream of fresh cold air supplied near the floor to slowly “displace” the stale air up toward the ceiling from where it leaves the room. This stratifies the air in the room, with warm stale air concentrated above the occupied zone and cool fresher air in the occupied zone (the occupied zone is the space in a room where people

²⁰ Much of the cooling savings relative to conventional systems comes from the higher evaporator temperature used to realize the higher air delivery temperatures. In moderately humid climates, such a scheme would necessitate a dedicated outdoor air system (DOAS) to provide humidity management, in which case a significant portion of the savings would be attributed to the DOAS and not displacement ventilation.

are, usually limited to six feet above the floor). Air quality is further improved when the thermal plumes rising from people in the space draw cool air up from the floor in a layer of fresh air along each person's body to his face. Figure 4-2 illustrates the differences between mixing and displacement ventilation systems.

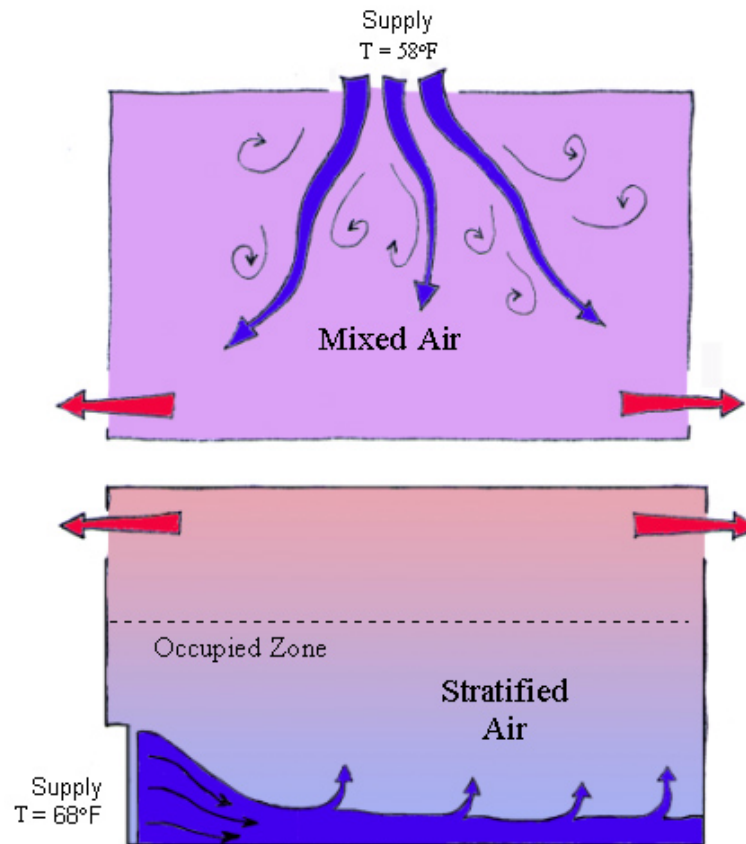

Figure 4-2: Illustrations of Mixing (top) and Displacement Ventilation (bottom)

Displacement ventilation faces several design challenges that make it difficult to implement properly. On its own, displacement ventilation does not effectively heat buildings, forcing designers to often use a supplemental heating system in buildings with high heating requirements. Displacement ventilation is also limited during the cooling season because the stratified air becomes uncomfortable for occupants (causing “cold feet”) in typical buildings when the cooling load exceeds $\sim 13 \text{ Btu/hr-ft}^2$ (40 W/m^2). However, the maximum cooling load can be increased to an upper limit of $\sim 40 \text{ Btu/hr-ft}^2$ (120 W/m^2) in buildings with very tall ceilings, low fresh-air ventilation rates, supplemental cooling systems (e.g. chilled beam/ceiling), or large diffusers (such as raised perforated floors).

Humidity control is also a concern with displacement ventilation, as higher cooling supply air temperatures decrease the ability of the HVAC system to manage moisture and could lead to moisture-related problems. Consequently, buildings employing displacement ventilation in many climates require a tight building envelope and separate treatment of

outdoor air to limit indoor moisture levels. Buildings with high internal moisture loads (e.g., swimming pools) are not appropriate environments for displacement ventilation.

When properly implemented, displacement ventilation reduces air-conditioning energy consumption, increases blower energy consumption, and has little impact on the energy consumed by boilers and furnaces. It reduces air-conditioning energy consumption in four ways. The first two apply to all displacement ventilation systems when compared to conventional mixing ventilation, and the last two only apply to certain systems.

1. The air-conditioning cycle COP increases for displacement ventilation because the supply air temperature (~65°F to 68°F) is not as cool as it is for mixing ventilation (~55°F to 58°F)²¹. This allows higher refrigerant evaporator temperatures in the air-conditioning equipment, which reduces the temperature lift across the compressor and increases the COP of the cycle. As noted above, the increase in evaporator temperature, however, is limited by the dehumidification requirements of the system. In applications using a dedicated outdoor air system (DOAS) to provide humidity management, most of these savings would be attributed to the DOAS and not displacement ventilation.
2. The stratified air in a space using displacement ventilation results in a higher average room air temperature than mixing ventilation resulting in reduced heat transfer through walls and especially the roof of a building.
3. For HVAC systems with economizers, the number of hours available for economizing increase when using displacement ventilation because the supply temperature is higher (so the allowable outdoor temperature/enthalpy for economizing increases). This would vary significantly with climate, e.g., moisture issues in more humid climates would limit this benefit.
4. When using demand-controlled ventilation, the required fresh-air for a displacement ventilation system could potentially be lower than for mixing ventilation because thermally-linked pollutants are trapped near the ceiling in the stratified air.

Fan power consumption is higher for displacement ventilation than for mixing ventilation because fans must supply more air to each space to meet the cooling loads when the supply temperature is warmer. Since displacement ventilation is fundamentally suited for cooling, not heating, supplemental heating systems are most likely required so the heating loads would not, therefore, be different between displacement and mixing ventilation systems.

Because there is such variation in the energy savings potential of displacement ventilation depending on system type, it is useful to establish logical assumptions about the displacement ventilation system. For the purposes of this study (performance and cost), the following assumptions about the HVAC system apply:

²¹ Turpin (2002) reports that rooftop A/C units supplying higher-temperature air for underfloor systems require minor factory modification.

- A supplemental heating system (hydronic radiant heat for example) is used in all displacement systems,
- Large wall-type diffusers are used to provide the low-velocity flow of chilled air of displacement ventilation, but supply and return duct sizes are the same for both displacement and mixing systems,
- Displacement ventilation can be used with central and unitary HVAC systems, but not individual systems,
- Economizers are included in all mixing and displacement ventilation HVAC systems,
- Demand-controlled ventilation is not considered (constant outdoor air supply rate is based on maximum occupancy and/or floor area).

While results will change when different assumptions are made, the above assumptions are reasonable estimates of how actual displacement ventilation systems would be installed in the United States.

4.3.3 Performance

Summary: Research studies of displacement ventilation have focussed on simulated computer models of various buildings in several U.S. climates. Studies over the last two decades vary considerably in their energy consumption estimates depending on the type of HVAC system, the building type, and the climate investigated. Compiling results from the studies and independent calculations based on reasonable assumptions indicate that electricity consumed by cooling equipment (i.e., the compressor) will decrease by ~30% to 75% with displacement ventilation (highly dependent on climate) while electricity consumed by supply and return fans will increase by ~35% to 50% (depending on building type). The result is a net primary energy savings potential of 0.20 quads.

Table 4-9 presents the percent savings or loss values used to calculate the potential primary energy savings of displacement ventilation. The electricity consumed for cooling is always lower for displacement ventilation than it is for mixing ventilation and the electricity consumed for supply and return fans is always greater. For different climates and building types there is a variation in cooling energy savings and fan energy losses because the increased hours of economizing and reduced thermal envelope loads vary substantially between them.

Table 4-9: Annual Site Energy Savings for Total U.S. Energy Savings Potential Estimate by Region and Building

Climatic Zone	Building Type	% Electricity Savings for Supply and Return Fans	% Electricity Savings for Cooling Equipment
Northeast	Office/Mercantile	-40%	40%
	Food Services/Health	-45%	40%
	Education/Lodging	-35%	40%
	Warehouse/Public	-50%	40%
Midwest	Office/Mercantile	-40%	38%
	Food Services/Health	-45%	38%
	Education/Lodging	-35%	38%
	Warehouse/Public	-50%	38%
South	Office/Mercantile	-40%	29%
	Food Services/Health	-45%	29%
	Education/Lodging	-35%	29%
	Warehouse/Public	-50%	29%
Mountain	Office/Mercantile	-40%	40%
	Food Services/Health	-45%	40%
	Education/Lodging	-35%	40%
	Warehouse/Public	-50%	40%
Pacific	Office/Mercantile	-40%	75%
	Food Services/Health	-45%	75%
	Education/Lodging	-35%	75%
	Warehouse/Public	-50%	75%
Total Primary Energy Savings		-0.26 Quads	0.46 Quads

Notes: The general magnitude of the savings for an office building came from the independent calculations for this study, the variation by building type came from Hu et al. (1999), and the variation by climate came from Zhivov and Rymkevich (1998) and the independent calculations. The quad savings are based on a tally of the savings for all central and packaged HVAC systems by region and building type.

Zhivov and Rymkevich (1998) simulated displacement ventilation systems in a prototypical sit-down restaurant in five U.S. cities (Minneapolis, Seattle, Albuquerque, Phoenix, and Miami) with the BLAST software program. They found that climate had a notable impact on energy savings and that cooling energy savings were significant and similar for systems with both demand-controlled fresh air rates and constant fresh air rates. They show that heating energy increases for all cities because the ventilation effectiveness decreases when heating with a displacement ventilation system (they did not use a supplemental hydronic heating system in their simulations like Hu et al.). Zhivov and Rymkevich considered the effects of increased economizing, increased cycle COP, and increased fan power, but did not consider reduced thermal envelope loads. Table 4-10 reproduces their results for a constant outdoor air system.

Table 4-10: Zhivov and Rymkevich (1998) Cooling Energy Savings for Displacement Ventilation

Location	% Electricity Savings for Cooling Equipment
Albuquerque	22%
Miami	13%
Minneapolis	29%
Phoenix	18%
Seattle	45%

Calculations performed independently for this study (*not* in Table 4-10) simulate displacement ventilation systems using binned building load data for a small office building in five U.S. cities (Albuquerque, Chicago, Fort Worth, New York, and San Francisco). It considers the effects of increased economizing, increased cycle COP, and increased fan power, but does not consider reduced thermal envelope loads. It made the following estimates based on discussions in the literature and logical assumptions:

- Both systems are VAV systems;
- The supply air temperature of a conventional mixing ventilation system is ~58°F;
- The supply air temperature of a displacement ventilation system is ~68°F (this is typical according to Hu et al., 1999 and Yuan et al. 1999);
- Both systems require an outdoor airflow rate of 0.2cfm/ft²;
- The total pressure drop across the supply and return fans is 498Pa (2.0”H₂O) for mixing ventilation and increases linearly with increased airflow for displacement ventilation (same size ducts);
- The building setpoint temperature is 75°F;
- The exhaust temperature of the mixing system is equal to the setpoint, and is 6°F above the setpoint for the displacement ventilation system (this is typical according to Hu et al., 1999 and Yuan et al. 1999 but varies with ceiling height).

Table 4-11 shows the range of results based primarily on increased economizing, and also based on combined economizing and the increased cycle COP.

Table 4-11: Independent Results for this Study Showing Benefit of Displacement Ventilation in Small Office Buildings

	% Electricity Savings for Supply and Return Fans	% Electricity Savings for Cooling Equipment (Economizing Only)	% Electricity Savings for Cooling Equipment (Economizing + COP)
Albuquerque	-49%	23%	40%
Chicago	-46%	21%	38%
Fort Worth	-48%	9%	29%
New York	-44%	23%	40%
San Francisco	-25%	69%	75%

Although VAV-based displacement ventilation systems substantially increase supply and return fan air consumption, they achieve a net reduction in HVAC energy consumption due to decreased cooling energy relative to a VAV system. In addition, the San Francisco²² results demonstrate the significance of the savings associated with increased economizer operation in moderate climates, illustrating why displacement ventilation has achieved significant market share (in excess of 25% in offices according to Svensson, 1989) in Northern Europe. In contrast, the savings in other climates are less and depend more on the increased cycle COP and reduced thermal envelope loads than on economizer operation.

The cycle COP of air-conditioning equipment increases when the evaporator temperature is raised, decreasing the cycle temperature lift. Estimating that the evaporator temperature of an air-conditioner using R-22 is 15°F lower than the supply air temperature, and that the condensing temperature is fixed at 100°F the cycle COP increases by ~30% when the supply air temperature changes from 58°F to 68°F (as in a displacement ventilation system). Over a range of outdoor temperatures (i.e. - condenser temperatures) this increase in cycle COP ranges between ~25% and ~30%. Taking the average increase at ~28% gives a 22% reduction in electricity consumed for cooling in the cases considered. As noted earlier, however, in somewhat humid climates higher evaporator temperatures are only feasible if the outdoor air (OA) humidity is managed effectively, e.g., by a dedicated outdoor air system. In this case, much of the cooling savings afforded by higher evaporator temperatures are due to the DOAS, not the displacement ventilation paradigm.

4.3.4 Cost

Summary: The economics of displacement ventilation have not been well presented in the literature. While some attempts at first cost and energy cost savings have been documented, they are not comprehensive enough to suggest accurate economic conclusions. That said, a coherent economic estimate assembled from various sources suggests that payback periods fall between ~3.5 and 20 years, with a strong dependence on climate.

As with the performance estimates, some assumptions about the displacement ventilation system are necessary to make a meaningful comparison with a traditional mixing ventilation system. The same assumptions made for the performance section were made again (such as needing a supplemental heating system).

The literature quantifies the capital based on simplified data. Hu et al. (1999) suggest that the first cost of a displacement ventilation system in new construction is 5% to 17% more than that for a mixing ventilation system depending on building type, including a supplemental heating system and taking into account the reduced chiller size and increased air-handler cost. The increase in first cost varied between ~\$0.10 and \$0.50 per square foot.

As with any study of operating cost, the results are highly dependent on utility rates. Studies to date have taken only a simplified approach to calculating energy cost differences between displacement and mixing ventilation systems, multiplying the annual difference in electric

²² Hu et al. (1999) and Zhivov and Rymkevich (1998) found similar savings for Portland (Oregon) and Seattle.

energy consumption by a fixed average electric rate. For example, Zhivov and Rymkevich (1998) multiplied state average electric utility rates (\$/kWh in 1996) for each city they studied by the annual electric energy savings of a displacement ventilation system to show 12% to 19% savings in annual operating costs.

Assembling the data and making simplified assumptions of regional electric rates enables calculation of simple payback periods. Table 4-12 summarizes the increase in system cost, reduction in annual operating cost, and corresponding payback period for each region.

Table 4-12: Estimated Simple Payback Period for Displacement Ventilation Small Offices

	System Cost Increase (\$/ft²)²³	Operating Cost Reduction (\$/ft²/year)²⁴	Estimated Simple Payback Period
Northeast (\$0.10/kWh)	\$0.520	\$0.045	11.5 years
Midwest (\$0.05/kWh)	\$0.147	\$0.026	5.6 years
South (\$0.06/kWh)	\$0.098	\$0.029	3.4 years
Mountain (\$0.06/kWh)	\$0.147	\$0.039	3.7 years
Pacific (\$0.08/kWh)	\$0.392	\$0.016	24 years

It is interesting to note that displacement ventilation has very long payback periods in the Pacific region, even though tables 4-9 and 4-10 show the highest percent energy savings in that region. This reflects that commercial buildings in the moderate Pacific climate have relatively small annual cooling energy consumption, diminishing the absolute energy savings (and therefore cost savings) while the first cost of a displacement ventilation system does not change drastically.

No studies found show the energy savings in actual buildings or simulate real utility rate structures (including demand charges and on/off-peak rates); as such, the economics of displacement ventilation economics warrant further study.

4.3.5 Perceived Barriers to Market Adoption of Technology

In the US, most HVAC designers and contractors have little familiarity with displacement ventilation. Design guidelines and procedures, while partially documented in the literature (Zhivov et al. 2000; Yuan et al. 1999; Zhivov et al. 1997) are not clearly assembled or endorsed by industry, and have not been transferred into computer design programs. The fundamental complexity of a properly designed displacement ventilation system is very different from the established practice of mixing ventilation, and supplemental hydronic heating and cooling systems are often required (adding to design complexity and first-cost). In more humid climates, DV systems also may require separate management of outdoor air to manage the humidity because of the higher evaporator temperatures used by DV systems.

4.3.6 Technology “Next Steps”

Building on its popularity in Europe, it would be beneficial to verify the cost, energy savings, and IAQ benefits of displacement ventilation by studying how some of these

²³ Based on the added cost of heating system, added cost of AHU, and reduced cost of air-conditioner from Hu et al. (1999).

²⁴ Based on independent calculations of reduced electricity consumption by air-conditioner and increased electricity consumption by fans (times average regional electric rate).

buildings operate (studies in the U.S. are largely limited to simulations and room-scale verification experiments in test chambers). As part of this process, it would be important to note and address differences in building and OA cooling loads between climates to understand how readily DV would translate to different US climates. Subsequently, if warranted, a next step would be to carry out demonstration projects in the United States to demonstrate the *in situ* effectiveness of displacement ventilation. Finally, education and software design tools need to be developed to educate designers and contractors in the United States and increase their awareness and knowledge of the benefits and potential pitfalls of displacement ventilation. Potential development “next steps” would include implementation of air diffusers with the potential for higher air velocities during heating months to enable adequate “throw” of warmer air, e.g., a variable aperture diffuser (larger opening during cooling season, smaller opening during heating season).

4.3.7 References

Hu, S., Chen, Q., and Glicksman, L.R., 1999, “Comparison of Energy Consumption Between Displacement and Mixing Ventilation Systems for Different U.S. Buildings and Climates”, *ASHRAE Transactions*, vol. 105, no. 2, pp. 453-464.

Svensson, A.G.L., 1989, “Nordic Experiences of Displacement Ventilation Systems”, *ASHRAE Transactions*, vol. 95, no.2.

Turpin, J.R., 2002, “Renovated Roundhouse Gets New Rooftops”, *Air Conditioning, Heating & Refrigeration News*, 24 June, p. 21.

Yuan, X., Chen, Q., and Glicksman, L.R., 1998, “A Critical Review of Displacement Ventilation”, *ASHRAE Transactions*, vol. 104, no. 1, pp. 78-90.

Yuan, X., Chen, Q., and Glicksman, L.R., 1999, “Performance Evaluation and Design Guidelines for Displacement Ventilation”, *ASHRAE Transactions*, vol. 105, no. 1, pp. 298-309.

Zhivov, A.M. and Rymkevich, A.A., 1998, “Comparison of Heating and Cooling Energy Consumption by HVAC System with Mixing and Displacement Air Distribution for a Restaurant Dining Area in Different Climates”, *ASHRAE Transactions*, vol. 104, no. 2, TO-98-1-4.

Zhivov, A.M., Nielsen, P.V., Riskowski, G., and Shilkrot, E., 2000, “A Design Procedure for Displacement Ventilation, Part 1 of 2”, *HPAC Journal*, November, pp. 39- 49.

4.4 Electronically-Commutated Permanent Magnet Motors

4.4.1 Summary

Electronically commutated permanent magnet motors (ECPMs)²⁵ offer substantial energy savings for sub-fractional horsepower ratings relative to more common motor technologies (e.g., shaded pole), but have limited energy savings potential for integral horsepower (HP) motors due to the higher efficiencies of conventional induction motors in this size range and the additional losses of the electronic commutation circuitry required for operation of the permanent magnet motor alternative. As integral HP motors account for more than 80% of all commercial HVAC motor energy consumption, ECPMs cannot realize major energy savings in commercial HVAC applications. In addition, ECPMs cost significantly more than permanent split capacitor (PSC) induction motors due to smaller production volumes and the need for drive controls/electronics. Nonetheless, ECPMs offer reasonably attractive simple payback periods for several applications using fractional HP motors, such as PTAC blowers and small exhaust fans.

Table 4-13: Summary of Electronically Commutated Permanent Magnet Motor Characteristics

Characteristic	Result	Comments
Technical Maturity	Current	ECPM motors of <i>greater</i> than 1HP are not yet available in the market
Systems Impacted by Technology	All HVAC motors, i.e., fans and pumps	Almost all of the benefits from ECPMs are for ratings smaller than 2 HP
Readily Retrofit into Existing Equipment/Buildings?	Yes	Particularly for ventilation systems and pumps, less so for compressors
Relevant Primary Energy Consumption (quads)	2.9 / 0.7	In practice, ECPMs primarily realize cost-effective energy savings advantage for fractional HP ratings (~0.7 quads for fractional HP motors)
Technical Energy Savings Potential (quads)	0.15	Considering only exhaust fan, unitary condenser fans, and RAC, PTAC, Small and Medium unitary blowers
Approximate Simple Payback Period	2.5+ Years	Lowest for very small (~1/10 th HP) motors, increases with motor size
Non-Energy Benefits	Improved occupant comfort	Only for variable-speed operation, as this enables better matching of ventilation and heating/cooling needs, decreasing temperature swings.
Notable Developers/Manufacturers of Technology	A.O. Smith, Powertec Industrial Corporation, General Electric, Emerson, AMETEK	
Peak Demand Reduction	Depends	For fractional HP ratings, ECPMs offer substantial cost-effective peak demand reductions. In integral HP applications, where ECPMs provide relatively small cost-effective efficiency gains, electronic drive input current harmonic distortion may corrupt power quality where there is intensive use of these units.
Most Promising Applications	Fractional HP motors (e.g., for exhaust fans)	
Technology “Next Steps”	Cost reduction of ECPMs	

²⁵ Also known as Electronically Commutated Motors (ECMs)

4.4.2 Background

ECPMs, also known as brushless DC motors, use several magnets bonded to a rotor and a stator with electrical windings that generate a rotating magnetic field. As described in ADL (1999a), “as the rotor moves, the stator windings are commutated, i.e., switched in phase with the position of the permanent magnet poles on the rotor. To control commutation timing, rotor position is sensed and fed back to the brushless DC motor variable-speed drive (VSD) and used for timing the switching of the output transistors to control the current in the motor windings.” ECPMs behave like classic DC motors, as their speed is proportional to the voltage and the torque is proportional to the current. They require drive controls to operate properly. Consequently, because the incremental cost of providing voltage control (which controls the speed) via pulse width modulators (PWM) is negligible, ECPMs are inherently variable-speed motors. PWM switching is superimposed on the commutation switching, requiring no additional hardware.

Brushless DC motors save energy in two ways. First, variable speed operation matches the speed required by the application, enabling pumps, fans, and compressors to efficiently meet partial loads. This avoids cycling losses caused by on/off operation and throttling losses generated by flow throttling (e.g., with dampers or valves). Second, brushless DC motors typically offer superior efficiencies relative to conventional induction motors in the fractional HP class.

4.4.3 Performance

Summary: By themselves, ECPMs can achieve very moderate energy savings in HVAC applications, primarily because they only offer significant efficiency improvements (~10%+) relative to the commonly-used shaded pole induction motor in the sub-fractional HP range; integral HP motors account for the vast majority of most commercial HVAC energy consumption. When integrated with control and power electronics to achieve variable-speed operation, the combination can reduce energy consumption in most HVAC applications by at least 30% relative to a single-speed induction motor.

Figure 4-3 shows that ECPMs offer major efficiency gains relative to permanent split capacitor and shaded pole motors in the fraction HP size range (ADL, 1999).

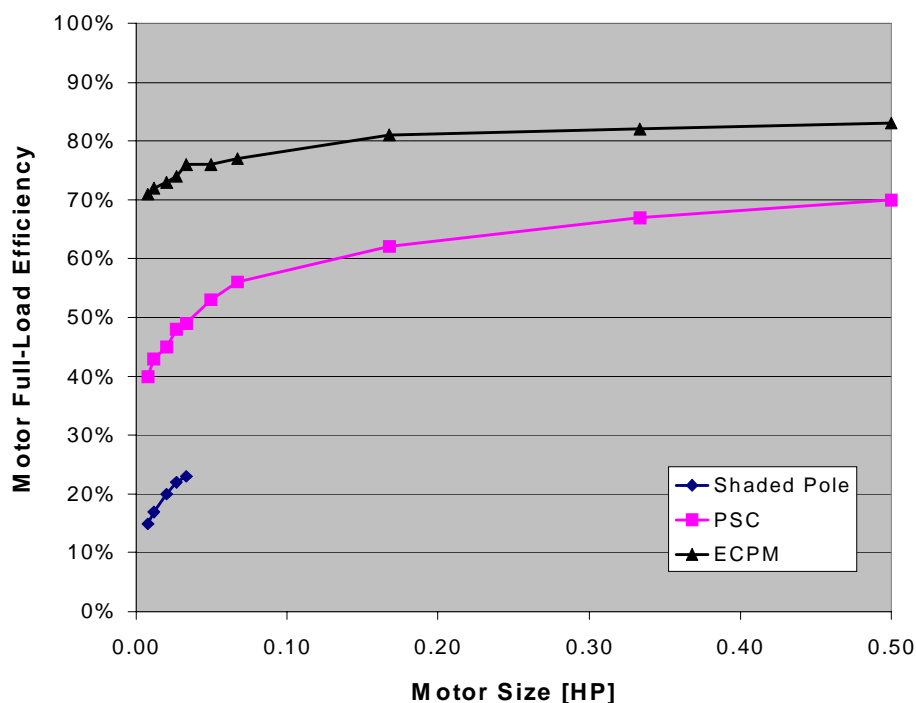

Figure 4-3: Sub-Fractional Horsepower Motor Efficiencies (for Refrigerator Fan Motors, from ADL, 1999)

Moreover, in the fractional HP range, ECPMs maintain their efficiency across a wider range of loads than conventional (three-phase) induction motors, i.e., an efficiency gap of at least 5% at full load will increase to 10-15% at lighter loads (ADL, 1999). Consequently, brushless DC motors can realize significant efficiency gains for RAC and PTAC blower applications, with somewhat smaller gains for small unitary blower and larger condenser fan motors (see Table 4-14).

Table 4-14: Fractional Horsepower Brushless DC Motor Energy Savings Potential in Commercial Buildings (from ADL, 1999)

Application	Motor Size (HP)	Energy Consumed (quads)	Energy Savings (%)	Energy Savings (quads)	Simple Payback (Years)
Room Air Conditioner Blower*	1/10 – 1/3	0.017	20%	0.0033	7.7
Packaged Terminal Air Conditioner Blower*	1/10 – 1/4	0.010	33%	0.0033	2.6
Small Unitary Blowers	1/4 - 3/4	0.066	33% ²⁶	0.022	N/A
Small Unitary Condenser Fan	1/4 - 1/2	0.026	33% ²⁷	0.0088	N/A
Medium Unitary Blower	1 - 5	0.091	11% ²⁸	0.010	N/A

*Includes condenser fan energy as well, as one double-ended motor drives both.

²⁶ Original calculation for 60% baseline, 80% efficient induction motor; assumed electronically commutated permanent magnet motor at 90% efficient.

²⁷ Original calculation for 60% baseline, 80% efficient induction motor; assumed electronically commutated permanent magnet motor at 90% efficient.

²⁸ Based on 80% baseline; assumed electronically commutated permanent magnet motor at 91% efficient.

To cite one specific potential application, simulations of a 10-ton unitary unit operating in a small New York City office building found that variable-speed operation of a brushless DC motor used for the condenser fan would reduce total unit energy consumption²⁹ during the cooling season by just over 6% relative to a conventional motor³⁰. This translated into a simple payback period of about 13 years³¹.

Although not listed in Table 4-14, exhaust fans may represent the largest (in magnitude) energy savings opportunity for brushless DC motors. The population of motors used with exhaust fans ranges from ~0.1 to more than 5HP in size³² and consumes 0.49 quads of energy. Assuming an average motor size of between 0.25 and 0.5HP, Figure 4-3 suggests that electronically commutated permanent magnet motors can improve motor efficiency from ~67% to ~82%, a technical energy savings potential of about 0.11 quads.

In practice, applications using integral HP motors account for the vast majority (>80%) of commercial HVAC motor energy consumption. EPACT minimum efficiency levels³³ apply to many integral HP (1HP+) motors, which limits the efficiency gains of ECPMs in this size range. Also, many manufacturers offer premium efficiency motors in integral HP sizes, further reducing the brushless ECPM-induction motor performance benefit.

By far, the potential for variable-speed operation offers the greatest benefit of ECPMs (see Variable Speed Drives section in Appendix A for details). The ECPM inherently requires drive electronics and controls to properly time the switching of the output transistors to control the current in the motor windings. Thus, for a small incremental cost of providing voltage control, ECPM readily become variable-speed motors, with the energy savings potential outlined in the VSD section (see Appendix A). It should be noted, however, that these savings are attributable to the VSD, and not unique to brushless DC motors. For fractional HP motors, ECPMs have approximately a 15% higher (absolute) efficiency than induction motors with a VSD (ADL, 1999).

4.4.4 Cost

Summary: ECPMs cost significantly more than induction motors in all size ranges. In the fractional HP range, studies suggest that ECPMs offer payback periods of 2.5 years and greater, in commercial HVAC applications.

Presently, ECPMs are significantly more expensive than induction motors due to the need for power electronics and controls, as well as much lower annual production volumes. Figure 4-4 presents OEM³⁴ costs of ECPMs relative to PSC motors for a refrigerator fan

²⁹ Compressor + blower + condenser fan.

³⁰ The same study found that a two-speed motor would reduce energy consumption by just under 6% with a simple payback period of ~2.7 years and that staging the operation of the two fans would achieve a 3.4% energy reduction with very favorable economics (simple payback period of ~0.2 years).

³¹ Based on \$0.076/kWh of electricity.

³² Based on product information from Loren Cook. Available at: www.lorencook.com.

³³ See, for example, ASHRAE (1999) for a listing of EPACT minimum efficiency motors.

³⁴ Assuming a mark-up factor of 2.5.

application. The ECPMs considered have the single-speed drive electronics integrated with the motor.

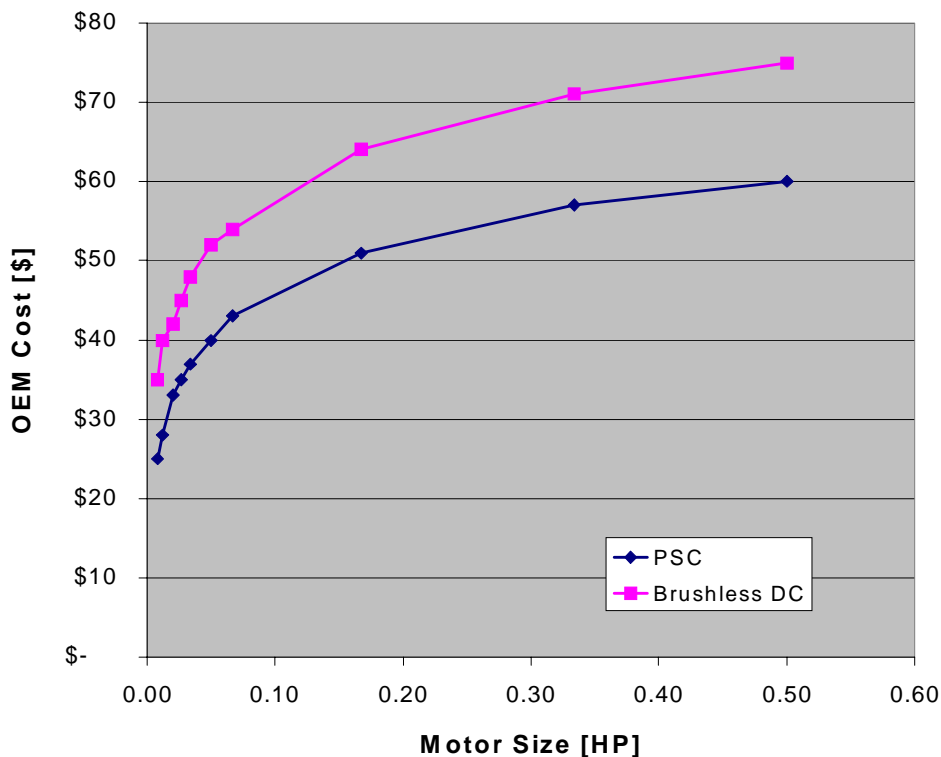

Figure 4-4: Brushless DC and PSC Motor OEM Costs (for Refrigerator Fan Application, from ADL, 1999)

In most HVAC applications, as motor size increases and the efficiency gains of ECPMs relative to induction motors decreases, ECPMs become unattractive in many HVAC applications. For example, ADL (1999) estimates that PTAC blower motors (1/10th to 1/4 HP) have about a two and one-half year simple payback period; for a RAC blower motor (1/10th to 1/3rd HP) the payback increases to almost 8 years (see Table 4-14, from ADL, 1999). Similarly, a variable-speed ECPM used as the condenser fan motor (1/4 HP) for the 10-ton unitary application discussed in the “performance” section has an OEM cost premium of ~\$160 for large volume purchases, with a ~13-year simple payback period. Exhaust fans appear to be a notable exception to this trend, with ECPMs offering about a two-year simple payback period relative to PSC motors due to a larger number of annual operating hours (assuming the ECPM prices from Figure 4-4).

Ultimately, with significant growth in production volumes, the price of fractional HP ECPMs (*without* integral or separately packaged electronic drive) is expected to approach that of premium efficiency induction motors (ADL, 1999). Similarly, fractional ECPM and induction motor drive costs should also converge (assuming large brushless DC motor volumes). Nonetheless, brushless DC motors currently cost about \$50/HP more than an induction motor with variable speed drive (Nadel et al., 1998).

4.4.5 Perceived Barriers to Market Adoption of Technology

The first cost of brushless DC motors relative to induction motors, primarily driven by drive electronics and controls cost and lower production volumes, is the primary factor preventing greater utilization of brushless DC motors in HVAC applications.

4.4.6 Technology “Next Steps”

Further cost reduction of brushless DC motors and their integral or separately packaged drive electronics/controls is essential to enable significant inroads into commercial HVAC applications. For instance, at least one company attempted to reduce stator cost by substituting a plastic stator “frame” for a conventional iron core, with mixed performance results (ADL, 1999). Overall, the continuing miniaturization and commoditization of controls and electronics should further reduce the cost of brushless DC motor control. A greatly increased demand for brushless DC motors with integral or separately packaged drive electronics – likely in an application outside of commercial HVAC³⁵ – is needed to realize the volumes necessary to reduce the cost of the motor itself.

4.4.7 References

ADL, 1999, “Opportunities for Energy Savings in the Residential and Commercial Sectors with High-Efficiency Electric Motors,” Final Report for the U.S. Department of Energy, Office of Building Technology, State and Community Programs, December. Available at: http://www.eren.doe.gov/buildings/documents/pdfs/doemotor2_2_00.pdf.

ASHRAE, 1999, “ASHRAE/IESNA Standard 90.1-1999: Energy Standard for Buildings Except Low-Rise Residential Buildings”, ASHRAE Press: Atlanta, Georgia.

Nadel, S., Rainer, L., Shepard, M., Suozzo, M., and Thorne, J, 1998, “Emerging Energy-Saving Technologies and Practices for the Building Sector”, American Council for an Energy-Efficient Economy (ACEEE) Publication, December.

4.5 Enthalpy/Energy Recovery Heat Exchangers for Ventilation

4.5.1 Summary

Air to air energy recovery heat exchangers can significantly reduce the energy needed to cool and heat ventilation make-up air. The technology is cost effective, with payback periods ranging from less than 1 year to 3 years in most applications. The technology can be used effectively in any building that is reasonably tightly constructed, with the return/exhaust air duct(s) located close to the fresh make-up air intake(s). Currently, ERVs are specified in only about 1% of the potential applications, so a large untapped potential for energy saving exists with this current technology.

³⁵ A more recent and notable success is the ECPM used in a direct-drive clothes washer by Fisher Pakell and also LG.

Table 4-15: Summary of Enthalpy/Energy Recovery Heat Exchanger for Ventilation Characteristics

Characteristic	Result	Comments
Technical Maturity	Current	Very limited (~1%) share of potential applications
Systems Impacted by Technology	Large fraction of all ventilation make-up air handling units	Need exhaust air from building to be directed close to where air intake is located. Building envelope needs to be “reasonably tight” so that small positive indoor air pressure can be maintained without losing all make-up air to exfiltration
Readily Retrofit into Existing Equipment/Buildings?	Yes	Subject to limitations noted above
Relevant Primary Energy Consumption (quads)	~1.3	Energy consumed to condition (heat or cool) ventilation make-up air to interior temperature/humidity
Technical Energy Savings Potential (quads)	0.5 to 0.6	Reduces OA conditioning (heating and cooling) energy and associated distribution energy by ~65%; consumes additional energy for pressure drop
Approximate Simple Payback Period	1-3 Years	Varies with location and building type.
Non-Energy Benefits	Improved humidity control and occupant comfort	Reduces cycling of AHUs and heating and cooling systems to decrease temperature swings
Notable Developers/Manufacturers of Technology	Airxchange, Aaon, Siebu Geiken, Semco, Munters	
Peak Demand Reduction	Yes, significant	Maximum cooling energy and power input savings occur in the hottest weather, significantly reducing peak demand at the same time that the electric grid overall is experiencing peak demand.
Most Promising Applications	Buildings in hot-humid climates or cold climates.	
Technology “Next Steps”	Demonstration – performance, cost savings, and reliability Education – disseminate credible information on performance and economics	

4.5.2 Background

Both technologies belong to the class of equipment known as heat recovery ventilators (HRVs) or energy recovery ventilators (ERVs), which are placed in ventilation units that take in outdoor air while venting indoor air. Figure 4-5 illustrates the basic arrangement, wherein exhaust air from the building interior passes through one side of the exchanger, counterflow to the incoming make-up air which passes through the other side of the exchanger. During the cooling season, the (cooler) indoor air passes through the heat wheel and cools that portion of the wheel. When the cooled portion of the wheel rotates into the (hotter) outdoor air stream, it pre-cools the incoming outdoor air. The transfer of heat reverses during the heating season, i.e., the heat wheel transfers heat from the warmer indoor air to pre-heat the incoming outdoor air. The heat exchanger may transfer sensible heat only or it may transfer both sensible and latent heat.

Several configurations of air to air energy recovery heat exchangers are in use. Plate fin arrangements transfer only sensible heat between the make-up and exhaust air streams.

Plate arrangements constructed with moisture permeable plastic can transfer latent heat as well, although no product based on this principle has been commercialized on a significant scale. Run around loops use a water loop to transport (sensible only) heat between separate air to water heat exchangers with each of the exhaust and make up air streams, when the make up and exhaust air streams are not located in close proximity to each other.

Heat and enthalpy wheels are slowly-rotating discs made of thin metal, plastic, paper or ceramic surfaces, such as honeycomb or a random woven screen mesh, to create very large surface areas. Enthalpy wheels use the same types of heat transfer surfaces and incorporate desiccant material, typically silica gel or a molecular sieve (adhered to the matrix material), that enable total enthalpy transfer, that is, both mass (moisture) and heat transfer. Implementation of energy recovery wheels in rooftop units is currently done on a limited basis, primarily in niche applications where the benefits are obvious, e.g., exhaust fan replacement in high-humidity locations and/or high makeup air applications.

When outdoor ventilation air is introduced into the interior space of a building at a higher or lower temperature than the interior temperature, it must be cooled or heated (respectively) to bring it to the space temperature. By using heat transfer with the exhaust air stream to pre-cool (during cooling season) or pre-heat (heating season) incoming outdoor air, heat exchangers reduce the sensible portion of the ventilation-induced air-conditioning and heating loads. Enthalpy wheels also transfer humidity and thus diminish the latent cooling and heating (dehumidification and humidification, respectively) portion of the ventilation load.

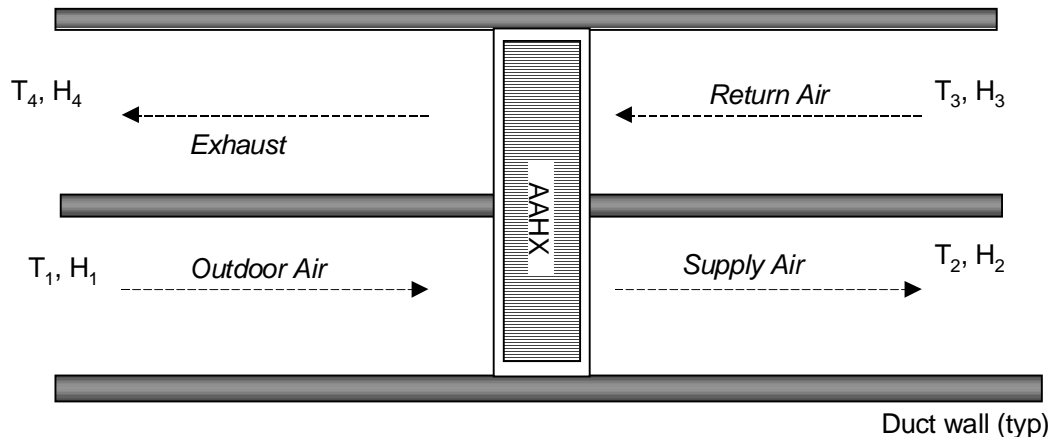

Figure 4-5: Generic Configuration of an Air-to-Air Heat Exchanger Used for Energy Recovery in Ventilation Applications

For an ERV to provide its potential precooling and preheating performance, it is necessary for the exhaust airflow to meet two key requirements:

- The flow rate must be a significant fraction of the make-up air flow rate (more than, say, 75%), and

- The temperature and humidity of the exhaust air must be close to that of the conditioned space (i.e., heat loss or gain in the return or exhaust ductwork must be small).

As illustrated in Figure 4-6, sound design and construction practices must be observed for the building envelope, so that it is reasonably air tight. In typical commercial buildings, roughly 10 to 15% of the make-up airflow rate is separately exhausted from bathroom exhausts, which may or may not be collected for enthalpy exchange. If the building envelope, including windows and doors, is reasonably leak tight, it can operate at a slightly positive pressure, preventing the infiltration of unconditioned air into the conditioned space, with minimal exfiltration, improving occupant comfort and reducing building energy consumption. The resulting flow rate of exhaust air that can be collected and passed through the energy recovery heat exchanger will be at least 80% of the make-up airflow rate.

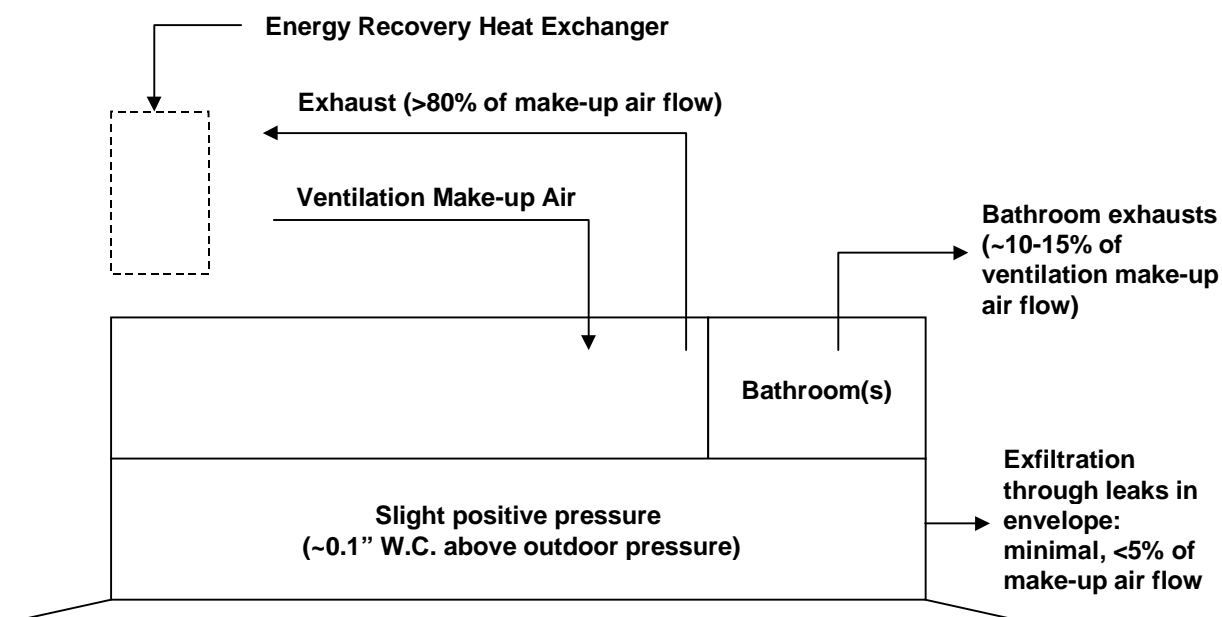

Figure 4-6: In a Tightly Constructed Building, the Exhaust Airflow Rate Through the ERV Equals a Significant Portion of the Make-up Air Flow Rate

Air to air energy recovery heat exchangers can be integrated with single package roof top unitary air conditioners, as shown in Figure 4-7. Currently, Aaon offers a complete product family with an integrated enthalpy exchanger. Alternatively, add-on accessory energy recovery heat exchanger packages are available as shown in Figure 4-8. Most major air-conditioning manufacturers offer such an option for select AC unit models.

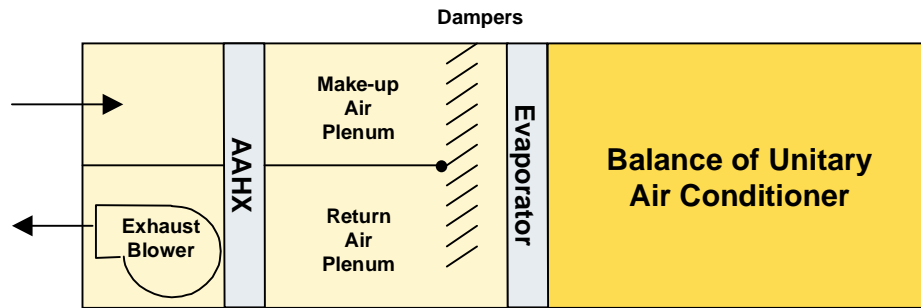

Figure 4-7: Unitary Air Conditioner with a Factory Integrated AAHX

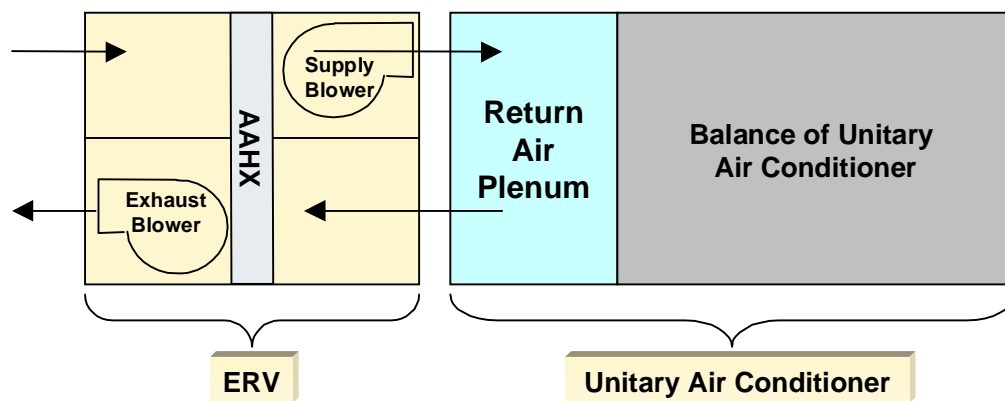

Figure 4-8: Add-on Accessory ERV with Supply and Exhaust Blowers Plus a Unitary Air Conditioner

4.5.3 Performance

Summary: Enthalpy and heat wheels can reduce peak heating and cooling loads by up to one-third, decreasing heating/cooling plant sizes; actual values depend greatly upon local climate and outdoor air requirements. A bin analysis for a New York City office building showed that a 10-ton packaged rooftop unit outfitted with an enthalpy wheel (deployed with an economizer, with economizer air flow *not* passing through the wheel) realizes about a one-year payback period (accounting for cooling plant downsizing), and reduced annual heating and cooling energy consumption by 35%. Heat and enthalpy wheels can approach 80% heat (and mass) transfer efficiency.

An ongoing TIAX study showed that on a rooftop unit, in small New York City (NYC) office, with VAV system, an enthalpy wheel would increase system total cost by 33%, but also substantially increase the floorspace (ft²) that the unit could serve. The net result was a ~6% increase in system cost. Annual energy savings equaled 35%, taking into account head losses, which translated into a 1-year simple payback period³⁶. When combined with an economizer in the same small NYC office application, different implementations achieved annual energy savings ranging from 35 to 49%, at 6-15% manufacturing cost premium (reflecting increase in system capacity), with simple payback periods ranging from 1-2

³⁶ Applying peak NYC electric rates for cooling saved, other wise national average for gas heating and electricity expenses

years³⁷. The exchange effectiveness of the device considered decreases from 80% to 60% as flow rate increases from 50% to 100% of design, while pressure drop increases from 0.5 in. to 1.0 in. W.C.

The ASHRAE (1996) Handbook indicates that typical performance for a flat plate (sensible only) effectiveness from 50-70% typical (counter-flow), (total enthalpy) effectiveness for an enthalpy wheel ranges from 55 to 85%, (sensible only) effectiveness for a heat wheel is ~50-80%; pressure drops (in inches of water): 0.4-0.7 (wheels), 0.1-1.5 (flat-plate heat exchanger). Xetex (2000, personal communication) product performance is in the range of 70% efficiency for enthalpy transfer and ~50-65% efficient for flat plate heat exchangers. Smith (1999) reported that an enthalpy wheel for large retail store located in Baton Rouge, LA reduced required unit capacity by 18%.

In a study by Collier (1997), which was primarily concerned with active desiccants, energy recovery heat exchangers were addressed as well. He assumed up to ~67% efficiency for enthalpy wheel. Energy consumption depends upon fan/motor power needed to overcome pressure drop and volumetric flow for system. Annual simulations summing both recovered energy (cooling and heating) and air moving power projected primary energy COP³⁸s ranging from 2.7 to 33.1, depending greatly upon face velocity, less upon geographic location.

4.5.4 Cost

The technology is cost-effective, not only due to energy cost savings, but also because the design conditions cooling capacity provided allows the air conditioning capacity for the building to be reduced, reducing the cost of the air conditioner. Average cost appears to be ~\$1.50/cfm for just the wheel. The range of estimated costs includes ~\$2.50/cfm (Besant and Simonson, 2000); \$4-\$5/cfm for basic energy recovery ventilator system in commercial buildings (Turpin, 2000); for enthalpy or heat wheels: ~\$1.25/cfm versus ~\$1/cfm for flat plate heat exchangers (Xetec, 2000); and price of ~\$3,000 for ~2,000cfm wheel (\$1.50/cfm; for complete cassette) (ADL, 2000). Under peak conditions, one ton of cooling equals roughly 170cfm³⁹.

4.5.5 Perceived Barriers to Market Adoption of Technology

Enthalpy/Energy recovery heat exchangers for ventilation suffer from a perception of higher first cost in the market place, in some instances because HVAC system designers do not take full credit for the offset in chiller capacity (cost) afforded by the device. Some applications cannot employ enthalpy/heat wheels because they require co-locations of air intakes and vents to function. Heat wheels are also perceived as having greater maintenance requirements than flat plate heat exchanger devices, due to moving part and past operational experiences. Fouling can also be a problem, particularly in colder climates during the heating season from frosting, because it decreases heat exchanger effectiveness and may lead to higher device pressure drop (and fan power) from increased flow blockage.

³⁷ Applying peak NYC electric rates for cooling saved, other wise national average for gas heating and electricity expenses

³⁸ Defined as the ratio of cooling/heating load displaced to the energy consumed to move air through the wheel and to turn the wheel.

³⁹ Assuming that the enthalpy exchange equals 70% and the following indoor and outdoor conditions: 75°F at 50% RH, 95°F at 67% RH.

4.5.6 Technology “Next Steps”

Demonstration and verification of cost/energy savings and operation reliability and maintainability of current technology products, as well as in-depth analyses of cost- and energy-savings in different locations and for different building types.

4.5.7 References

ADL, 2000, “Energy Efficient Rooftop Air Conditioner: Continuation Application Technical Progress Statement”, Presentation on 7 November, Project #: DE-FC26-99FT40640.

ASHRAE, 1996, **ASHRAE Handbook: HVAC Systems and Equipment**: Chapter 42: Air-to-Air Energy Recovery, ASHRAE Press: Atlanta, Georgia.

Besant, R.W. and Simonson, C.J., 2000, “Air-to-Air Energy Recovery”, *ASHRAE J.*, May, 2000, pp. 31-42.

Collier, R.K., 1997, "Desiccant Dehumidification and Cooling Systems: Assessment and Analysis", Final Report to Pacific Northwest National Laboratories, PNNL-11694, September.

DOE, 2000, “TECHNICAL SUPPORT DOCUMENT: ENERGY EFFICIENCY STANDARDS FOR CONSUMER PRODUCTS: RESIDENTIAL CENTRAL AIR CONDITIONERS AND HEAT PUMPS.” October, 2000, U.S. Department of Energy.

Smith, C.S., 1999, “Ventilation in the Commercial Environment”, *ASHRAE J.*, October, pp. 73-76.

Turpin, J.R., 2000, “Hybrid Systems Offer the Best of Both Worlds”, *ACHRNews*, 2 October, p. 18.

Xetex, 2000, Personal Communications with K. Petersen and J. Tong. Related information available at: http://www.xetexinc.com/energy_frame/main.html .

4.6 Heat Pumps for Cold Climates (“Zero-Degree” Heat Pumps)

4.6.1 Summary

A heat pump that is optimized and selected for low ambient temperature heating loads would extend the range of applicability of heat pumps into the Northern half of the US, displacing some electric resistance heat. Heat pumps are not widely used in commercial air conditioning because gas heat is currently a relatively inexpensive add-on for rooftop air conditioning equipment and generally provides lower cost heating. The potential for increased market share and the energy savings potential is correspondingly small.

Table 4-16: Summary of Heat Pump for Cold Climates Characteristics

Characteristic	Result	Comments
Technical Maturity	Advanced/new	3-4 years
Systems Impacted by Technology	Space heat - North	
Readily Retrofit into Existing Equipment/Buildings?	Depends	Yes-if air distribution ductwork exists for warm air distribution (replacing gas-fired unit with a heat pump unit). No-if no ductwork exists, e.g., heat is by individual room electric resistance heating units.
Relevant Primary Energy Consumption (quads)	1.2 quads	All commercial building non-heat pump heating systems in the Northeast, Midwest, and Mountain regions of the U.S.
Technical Energy Savings Potential (quads)	0.1	Roughly 10% heating primary energy savings for a heat pump sized for the heating load, relative to a gas furnace
Approximate Simple Payback Period	4-5 Years No payback	4-5 years vs. conventional heat pump No payback (energy cost is higher) vs. gas fired heat.
Non-Energy Benefits	Improved occupant comfort	Warmer air delivery temperature reduces heat pump “cold blow” effect.
Notable Developers/Manufacturers of Technology	U. Illinois, Champaign-Urbana (improved performance at lower temperatures); U. Maryland, Purdue U. (CO ₂ heat pumps); Global Energy Group offers multiple compressor heat pumps.	
Peak Demand Reduction	Probably	Increased heating efficiency reduces winter peak demand; some design approaches would also improve cooling efficiency, reducing summer peak demand as well.
Most Promising Applications	Displacement of electric resistance heating	
Technology “Next Steps”	What are costs and energy savings benefits of dual-compressor systems? What are energy savings for other compressor types and in different climates?	

4.6.2 Background

Conventional air source heat pumps are in essence an air conditioner with a reversing valve and a few other minor components added to allow the vapor cycle to pump heat either out of the conditioned space (for space cooling) or into the conditioned space (for space heating). The resulting increase in cost is very small, compared to an air conditioner with electric resistance heating, and much less than the cost of adding a gas furnace. The vast majority are installed in moderate to warm areas of the U.S. Typically, the capacity is specified to meet the cooling requirements of the building. Whatever heating capacity this provides is used in preference to electric resistance heat, which is used to supplement the output of the heat pump as needed to meet the heating load. The capacity of vapor cycle heat pumps falls rapidly as the outdoor temperature falls -- typically the capacity at a 17°F ambient temperature is only half of the capacity at a 47°F ambient temperature. The heating load of the building, on the other hand, increases as the ambient temperature falls. In the warmer parts of the U.S. (essentially south of the Mason-Dixon Line), the length of the heating season and the range of outdoor temperatures during the heating season is such that the heat

pump is able to meet most of the heating requirements, with relatively little electric resistance back-up heating. This results in much lower electric energy consumption (and heating costs) than would be incurred with the least expensive space conditioning alternative for these areas, an air conditioner with electric resistance heating. For conventional heat pumps, the avoidance of electric resistance heating is the primary basis of energy savings. In fact, even at moderate outdoor heating season temperatures (~45-50 °F), the primary energy efficiency to heat with a heat pump is only comparable to that of a conventional condensing gas furnace, while at lower ambient temperatures the primary energy efficiency of the heat pump is less. In colder climes, significant amounts of electric resistance heat are needed, resulting in heating performance that is both expensive and unsatisfactory.

A “Zero-Degree” heat pump is a concept for heat pump designs that work effectively in cold climates (down to 0°F), and is not limited to any single technology. There are two major reasons why traditional heat pumps are not suitable for heating in cold climates. The first reason, as discussed above, is that cooling design loads are smaller than heating design loads (by a wide margin in cold climates), so heat pumps will either be undersized for heating (requiring supplementary heating) or oversized for cooling (meaning higher equipment cost and lower operating efficiency for traditional single-compressor systems). The second reason is that the heating cycle efficiency decreases when the outdoor air temperature decreases because the temperature lift across the compressor increases. Several design modifications and technologies have been proposed or introduced (alone and in combination) for heat pumps to overcome these two obstacles including variable-capacity compressor systems and ground/water coupled systems (Walters, 2000).

Ground/Water-coupled systems: The problem of reduced heating cycle efficiency in cold ambient air is effectively eliminated when the evaporator extracts heat from ground water or service water (at a higher and more constant temperature than outdoor air). In these systems, heat pumps offer near-constant heating and cooling efficiencies year-round. Ground/Water-coupled systems do not address the problem of mismatched heating and cooling capacities, but can be sized based on the design heating load. The resulting over sizing for cooling can be accepted (in cold climates the cooling season is short and the cumulative penalties of being oversized for cooling are not great) or corrected by using dual compressors or a variable capacity compressor such as a Bristol Twin Single™ (TS; see write-up in Appendix A). While the major emphasis in work on cold climate heat pumps has been geothermal heat pumps, the primary obstacle to widespread use is the cost of installing the ground heat source. The “Geothermal Heat Pumps” section in Appendix A covers this approach separately. This section addresses options to improve air source heat pumps.

Variable-capacity compressor systems target the first obstacle of mismatched loads. Options include dual-compressors, a variable-speed compressor, or a variable-cylinder reciprocating compressor. Essentially the compressor capacity is sized such that heating design loads are met at full compressor capacity, while the cooling design loads are met by partial (yet still efficient) compressor capacity. Variable-capacity compressors do not

address the problem of reduced heating cycle efficiency in cold ambient air (Biancardi and Sienel, 1997). The rest of the “Zero-Degree Heat Pump” section focuses on this approach.

Most of the experience with conventional heat pumps is in residential space conditioning applications, with relatively little application to commercial space conditioning. Commercial applications may be inherently suitable for incrementally colder weather than residential applications, because more cooling capacity is needed for internal loads and to offset higher air moving power consumption. In heating mode, the larger cooling capacity translates into more heat pump heating capacity and the internal loads and air moving power reduce the net heating required. On average, this might shift the range of suitable climates by approximately 5°F colder compared to residential applications. For colder climates still, extra measures are needed to improve air source performance.

Down to temperatures of ~40°F, heat pumps consume less primary energy than gas boilers or furnaces to deliver the same quantity of heat and substantially less primary energy than electric resistance heat. If heat pumps could be designed to deliver sufficient heating capacity and to achieve higher primary energy efficiencies at substantially lower temperatures (approaching 0°F), heat pumps could reduce heating energy consumption over a larger region of the northern U.S. than is possible today. Options to accomplish this include:

- Multiple compressors or a dual compressor with variable or stepped capacity (e.g., the Bristol TS compressor), so that added capacity can be brought into play as the outdoor temperature falls and the building space heating load increases.
- Increased outdoor coil capacity (more surface area, more face area, increased fan capacity) to allow more heat to be extracted from low temperature ambient air with less temperature difference between the entering air and the evaporating refrigerant. This is effectively the same thing as oversizing the outdoor side of the heat pump, but in conjunction with the variable compressor capacity does result in higher cooling mode EER.
- CO₂ is a promising refrigerant option for low ambient temperature heat pumps because the vapor temperature pressure curve is flatter than for conventional refrigerants (providing greater capacity at lower ambients than a similar capacity conventional heat pump would provide). Heat rejection is spread out over a wider temperature range, so that higher air delivery temperatures can be obtained without thermodynamic penalty (Richter et al., 2000).
- Using mechanical liquid subcooling to provide an incremental increase in both capacity (by ~10%) and efficiency (by ~5%) .
- Optimizing indoor and outdoor coil circuiting for heating mode.

4.6.3 Performance

Summary: Variable-capacity compressor heat pumps sized for larger heating loads will save approximately 3-10% in primary energy consumption compared with a smaller heat pump sized only for the smaller cooling loads. A preliminary analysis of a similarly-sized CO₂

heat pump suggests that it might consume slightly more than one using a conventional refrigerant, as lower COPs offset reductions in electric resistance heating.

TIAX performed a simple analysis, using a ~10 EER packaged heat pump, with binned weather data for a small office in Chicago. The analysis compared a 5-ton heat pump (sized for cooling design load) using a two-stage compressor (variable cylinder-type, Bristol TS™) against a 10-ton heat pump (sized for heating design load) comprised of one 5-ton variable-capacity compressor and one 5-ton standard compressor. In addition, both options were compared to a conventional heating option, i.e., an 80% AFUE furnace (see Table 4-17).

Table 4-17: Energy and Cost Comparison to Furnace

System Type	Estimated System Price Premium ⁴⁰	Operating Cost	Simple Payback Period [years]	Primary Energy Consumption [MMBtu] ⁴¹
Furnace (80% AFUE)	Baseline	\$510	Baseline	102
5-ton Heat Pump (Dual-Capacity Compressor)	\$0	\$910	5 to 6	126
10-ton Heat Pump (5-ton dual capacity + 5-ton single-capacity compressor)	\$1,150	\$680	Never	93

The analysis showed that the 10-ton unit reduced primary energy consumption for heating by about 25% relative to the 5-ton unit. Relative to an 0.80 AFUE furnace (averaged over that climate), the 10-ton HP would save about 10% in *primary* energy consumption terms.

Test data of Richter et al. (2000) et al. show that with carbon dioxide used as the working fluid, the low ambient temperature (-8.3°C or 17°F) capacity is approximately 35% higher than would be the case with R-410A, assuming both systems are sized for the same cooling capacity at ARI standard conditions. By itself this is not sufficient to meet the heating load at 0°F, but it significantly reduces the amount of oversizing relative to the design cooling load (or use of electric resistance back-up heat) necessary to meet the load at this temperature. On the other hand, the CO₂ HP exhibited about a 10% decrease in COP relative to the R-410A HP over a range of evaporator temperatures.

A model was also developed for 5- and 10-ton CO₂ HP using the same compressor configuration as above (i.e., a single 5-ton Bristol TS™, and a 5-ton TS plus a 5-ton standard compressor, respectively), based on performance data from Richter et al. (2000) et al. (see below), serving a small office building in Chicago. Relative to a conventional 5-ton HP, the 5-ton CO₂ HP reduced primary energy consumption by ~5%, due to the increased capacity of CO₂ systems at lower evaporator temperatures. On the other hand, the 10-ton CO₂ HP actually consumed about 7% more energy than a conventional 10-ton HP, as the increase in energy consumption due to decreased cycle COP over all of the heating hours exceeded the gains from reductions in electric resistance heating. As the model used very

⁴⁰ Assumes 2.5 markup factor.

⁴¹ Assumes 11,958Btu per kWh of delivered electricity.

simple and rough assumptions based on limited available data, and did not consider any potential optimizations for heating season performance, this result should be considered preliminary.

4.6.4 Cost

Summary: For a small office in the Chicago climate, an “oversized” heat pump⁴² (i.e., sized to meet the heating load,) will payback in ~5 years relative to a heat pump sized to meet the cooling load (based on the performance information outlined above). However, relative to a furnace, the “over-sized” heat pump cannot pay back because it has a greater first cost and will cost more to operate than a gas or oil furnace. Very little cost analysis has been done to allow a reliable estimate of the difference of equipment cost between CO₂ and conventional refrigerants. Air conditioning industry experts have indicated that a cost premium for CO₂ of at least 20% could be expected at roughly comparable EER (ADL, 2002).

Walters⁴³ (2000) argues that “the application of dual units or two-speed compressors is cost-prohibitive. A two-speed compressor requires five terminal connections, interlocking contactors, and external motor protection, so that in some cases a dual unit costs more than twice that of a single compressor”. He advocates using a dual-capacity compressor to provide the necessary capacity modulation cost effectively. The incremental cost amounts to the incremental cost of the higher capacity dual-capacity⁴⁴ compressor versus the lower capacity single speed compressor. On the other hand, a dual unit may have a similar cost if the compressors are produced in sufficiently large volumes, e.g., in larger commercial rooftop air conditioners, dual compressors are used frequently. Adding compressor capacity for use at low ambient temperatures adds primarily the cost of the extra compressor capacity. Both approaches are a minimalist approaches, with modest cost impact, but correspondingly modest impact on lowered balance point and no improvement of low ambient efficiency. While both can lower the balance point, the heat pump efficiency continues falling with ambient temperature, so the approach is attractive only relative to using electric resistance heat.

According to Nastro (2002), 5- or 10-ton unitary equipment (a small, single-package commercial rooftop unit), a unit with a heat pump has about the same first cost as a unit with A/C and a gas furnace section. Note that the installed costs for latter will be higher by the cost of installing the gas service.

Using the same analysis as above (in the performance section, for an office building in Chicago), TIAX calculated the incremental cost and payback (see Table 4-17). The variable-capacity compressor system has a ~5-year payback compared to a 5-ton heat pump without the extra compressor capacity. Rather than using a standard 5-ton compressor and a variable-capacity 5-ton compressor, a single variable-capacity 10-ton compressor may be a

⁴² The “over-sized” system has twice the capacity required to meet the cooling load, using a 5-ton single-speed compressor and a 5-ton dual-capacity Bristol TS™; this is compared to a 5-ton single-speed compressor.

⁴³ On the referenced paper, Walters is identified as an employee of the Bristol Compressor company, a company that manufactures the dual-capacity Twin-Single compressor.

⁴⁴ The dual-capacity compressor referred to by Walter (2000), the Bristol Twin-Single, only applies to small commercial heat pumps because the TS product line only goes up to 5.4 tons.

cheaper design option, which would shorten the payback a bit. Based on the information provided by Nastro (2002), unitary equipment equipped with a 10-ton heat pump would cost *more* than a 5-ton AC unit equipped with a furnace due to the price of a second (or larger) compressor. However, because a gas or oil furnace has a lower heating season operating cost (by ~20%⁴⁵), the over-sized HP option cannot pay back.

4.6.5 Perceived Barriers to Market Adoption of Technology

A general perception exists that heat pumps do not represent a viable heating option for cold climates. The lack of cost-effectiveness compared to conventional gas space heating options limits the attractiveness of this option to situations without gas, where heat pumps can displace electric resistance heat.

4.6.6 Technology “Next Steps”

A more thorough design study of a CO₂ based roof top cold climate heat pump in the 10- to 25-ton cooling capacity range would provide a basis for comparing the primary energy efficiency with other alternatives – gas warm air furnace in particular – and for estimating the manufacturing cost premium over conventional roof top air conditioners (with gas heat). The use of design options such as added compressor capacity, mechanical subcooling, and circuit optimization for heating mode should be evaluated/optimized in this design exercise.

4.6.7 References

ADL, 2001, “Energy Consumption Characteristics of Commercial Building HVAC Systems, Volume I: Chillers, Refrigerant Compressors, and Heating Systems”, Final report prepared for the U.S. Department of Energy, Office of Building Technology, State and Community Programs, April.

ADL, 2002, “Global Comparative Analysis of HFC and Alternative Technologies for Refrigeration, Air Conditioning, Foam, Solvent, Aerosol Propellant, and Fire Protection Applications”, Final Report to the Alliance for Responsible Atmospheric Policy, March 21.

Biancardi, F.R. and Siemel, T.H., 1997, “Advanced Concepts for Cold Climate Heat Pumps”, *Proceedings of the Third International Conference on Heat Pumps in Cold Climates*, Natural Resources Canada, pp. 325-337.

Glaze, K., 2001, Personal Communication. Global Energy and Environmental Research, Inc.

Richter, M.R., Song, S.M., Yin, J.M., Kim, M.H., Bullard, C.W., and Hrnjak, P.S., 2000, “Transcritical CO₂ Heat Pump for Residential Applications”, *Proceedings of the 4th IIR-Gustav Lorentzen Conference on Natural Working Fluids*, Purdue University, July.

Nastro, T., 2002, Personal Communication, The Trane Company.

⁴⁵ Assuming a cost of \$5.00/million Btu and \$0.07/kW-h for electricity.

Walters, J. 2000, “Applying TS Technology to Cold Climate Heat Pumps,” *Proceedings of Heat Pumps in Cold Climates. Fourth International Conference*, December.

4.7 Improved Duct Sealing

4.7.1 Summary

Duct leakage is a significant source of wasted energy in HVAC systems and both poor workmanship and failure of seals contribute to leaky ductwork. Aerosol duct sealing systems effectively seal existing leaks but do not guarantee that the seals will not fail in the future – especially if the ductwork was poorly supported – and the joints pull apart over time due to thermal and pressure cycling. To reduce energy losses from duct leakage, future efforts should focus on improving the quality of duct installation.

Table 4-18: Summary of Improved Duct Sealing Characteristics

Characteristic	Result	Comments
Technical Maturity	Current	Improved duct sealing processes are new to the market, such as the AeroSeal system (which, as of Y2000, had been applied to approximately 2000 residences).
Systems Impacted by Technology	All ductwork	Effects fan power, cooling energy, and heating energy in central and packaged HVAC systems.
Readily Retrofit into Existing Equipment/Buildings?	Yes	Improved duct sealing processes will either be applied to new ductwork, or to existing ductwork without requiring any major structural modifications.
Relevant Primary Energy Consumption (quads)	3.5	All heating, cooling, and parasitic energy associated with central and packaged ducted HVAC systems.
Technical Energy Savings Potential (quads)	0.23	Based on 6.5% decrease in cooling, heating, and supply/return/exhaust fan energy consumption (for aerosol sealing)
Approximate Simple Payback Period	7 to 14 years	Based on annual HVAC operating expenses of ~\$0.60/ft ²
Non-Energy Benefits	Reduced supply fan and heating/cooling equipment size	When sealed at time of installation, and only if HVAC designers consider the reduced leakage when sizing equipment.
Notable Developers/Manufacturers of Technology	AeroSeal, Inc.; LBNL	LBNL: Lawrence Berkley National Laboratory (DOE)
Peak Demand Reduction	Yes	The highest airflow rates occur at times of peak cooling loads (which generally correspond to peak electric loads), resulting in higher leakage rates.
Most Promising Applications	Small commercial buildings with first-cost constraints that are not commissioned and are, therefore, prone to poor workmanship. Single-story buildings (more ducting likely outside of conditioned zone. Areas with high electricity demand charges (peak loads).	
Technology “Next Steps”	Develop “fool-proof” standards for duct leakage that consider two primary factors: (1) duct design and craftsmanship issues that encourage low-leakage duct systems at time of installation/commissioning, and (2) structural duct support and sealant material property issues that minimize long-term seal failure due to thermal and pressure cycling. Develop additional approaches for existing systems (beyond aerosol sealing).	

4.7.2 Background

All ducts have some degree of leakage, but measurements by Fisk et al. (1998) of commercial building duct systems found that duct leakage exceeded the ASHRAE recommended leakage classes by roughly a factor of 20 (ASHRAE, 1998), and that connections in duct works (e.g., diffusers) are particularly leaky. Delp et al. (1997) observed several light-commercial duct systems riddled with faults, including torn and missing external duct wrap, poor workmanship around duct take-offs and fittings, disconnected ducts, and improperly installed duct mastic. Even with properly sealed ductwork, thermal cycling damages the adhesives in sealants – especially the rubber-based adhesive in duct tape – thus increasing leakage over time (Sherman and Walker, 1998). Pressure cycling also can wear out duct seals over time by virtually pulling the joints apart which leads to increased leakage – especially when the ductwork is not adequately supported during installation (Hamilton, 2002).

Aerosol duct sealant systems patch holes and cracks in leaky ductwork using an adhesive-aerosol spray. The system sprays a suspended adhesive mixture into the ductwork after workers remove diffusers and block all the ends to seal off the system (taking care to isolate any coils, dampers, etc. to prevent fouling). The suspended adhesive then moves throughout the pressurized duct system and leaves through any cracks or holes it finds sticking to the edges as it leaves and slowly forming a new seal.

Repairing and patching leaks in HVAC duct systems saves cooling, heating, and fan energy. Since the purpose of ductwork is to deliver heated or chilled air to a conditioned space, any leakage in the duct means that extra air must be supplied so that enough air reaches the conditioned space. Sealing any leaks in a duct system reduces the amount of heated or chilled air the supply fan must handle to deliver the same amount of air to the conditioned space.

4.7.3 Performance

Summary: On average, typical commercial buildings have duct systems that leak between 10% and 20% of the total air flow provided by the supply fan, with about half of the duct leakage outside the conditioned space. Using aerosol duct sealing methods reduces duct leakage to between 2% and 3% of the total air flow supplied, reducing cooling, heating, and parasitic energy consumption of duct-based HVAC systems by 4 to 9%.

While residential duct leakage is notorious, small commercial buildings actually suffer the worst duct leakage rates and large commercial buildings have the lowest duct leakage rates. Small commercial buildings are typically not commissioned (unlike larger buildings), so duct leakage problems are not identified and fixed. In addition, larger commercial building projects often involve a HVAC construction, leading to better construction practices and more oversight relative to many smaller commercial building projects.

Researchers report that, on average for all commercial buildings, between 10% and 20% of the total air provided by the supply fan is lost to leaks (Delp et al., 1997; Fisk et al., 1998; Xu et al., 2000). Not all the air that leaks from a duct is completely lost, however, since

approximately half the total ductwork in a typical building lies within occupied space (Delp et al., 1997; Modera, 2000). Aerosol duct sealing systems, such as AeroSeal®, are proven to significantly reduce duct leakage. In commercial buildings the aerosol sealing system has reduced duct leakage rates to between 2% and 3% (Modera, 2000). The problem of duct leakage, however, goes beyond simply sealing leaks. Ducts are often poorly supported causing the ductwork to “pull” apart when pressurized, and the seals may fail over time (Hamilton, 2002). Therefore, if a system was properly sealed when installed and the seals failed due to poor duct construction, then the aerosol sealing may provide only a temporary fix unless the root problem is fixed. Modera (2002) noted that existing duct work sometimes needs structural repair (if the duct has come apart at the joint for example) or manual sealing before the AeroSeal® sealing system can be applied.

Thus, duct leakage increases heating and cooling energy consumption by 4 to 9%. In addition, the air “lost” to the unconditioned space will require the fan to run at a higher level (for a VAV system) or longer (CAV) to deliver the needed space conditioning, increasing supply, return, and exhaust fan energy consumption by a similar 4 to 9%⁴⁶.

4.7.4 Cost

Aerosol duct sealing is a labor-intensive service that cost approximately \$0.40/ft² with small commercial buildings costing slightly less and large commercial buildings costing slightly more (due to multiple air-handling units). This reflects duct sealing costs between \$600 and \$1000 for residential service on a 2,000ft² home (Modera, 2000). Estimating that the average commercial building spends approximately \$0.60/ft² each year on HVAC energy consumption⁴⁷, on average an aerosol duct sealing service will payback in about 10 years. However, if the underlying duct assembly is poor, it is not clear how long the duct sealing will effectively last. An HVAC industry consultant who designs HVAC systems for higher-end residential construction estimates that taking the time to properly seal ducts will add on the order of \$0.20/ft² to the installation cost; however, ensuring proper installation (including testing/commissioning the ducts) could add as much as \$1/ft² (Hamilton, 2002).

4.7.5 Perceived Barriers to Market Adoption of Technology

Building owners who are more concerned with first-cost are more likely to have leaky duct systems, and will be less willing to pay for an aerosol sealing service. Few HVAC contractors are familiar with and trained in aerosol sealing technology. The duct leakage problem itself is not fully understood, and building owners are not aware of the potential savings associated with fixing leaky ductwork. Further, patching a leaky duct system without correcting any structural support problems will give only a short-term solution as the seals may fail again over time.

4.7.6 Technology “Next Steps”

While duct leakage is certainly a problem, its magnitude and causes are not fully understood in commercial buildings. The first step should be to better understand the reasons for duct

⁴⁶ In practice, fans are rarely altered once installed in a building. Thus, instead of “working harder” to move additional air that leaks away, they operate for a longer period to meet the building heating and cooling loads while potentially under-ventilating the space.

⁴⁷ Based on detailed energy consumption information per ft² from ADL (1999) and ADL (2001).

leakage in commercial buildings. Aerosol duct sealing is one fix for the problem, but other solutions are also available that might yield more permanent results in the case of poor construction/installation and warrant study. Stricter ductwork standards that cause contractors to properly install and seal ductwork is one such option (dictating flanged ductwork with gasketed seals for example, such as the MEZ system manufactured by Duro-Dyne – see Figure 4-9). Identifying and limiting the use of sealing materials that fail when subject to thermal cycling is another option (such as duct tape, which was shown to fail regularly by Sherman and Walker, 1998). Finally, better installation techniques and products that facilitate good duct installation will improve the likelihood of reduced duct leakage.

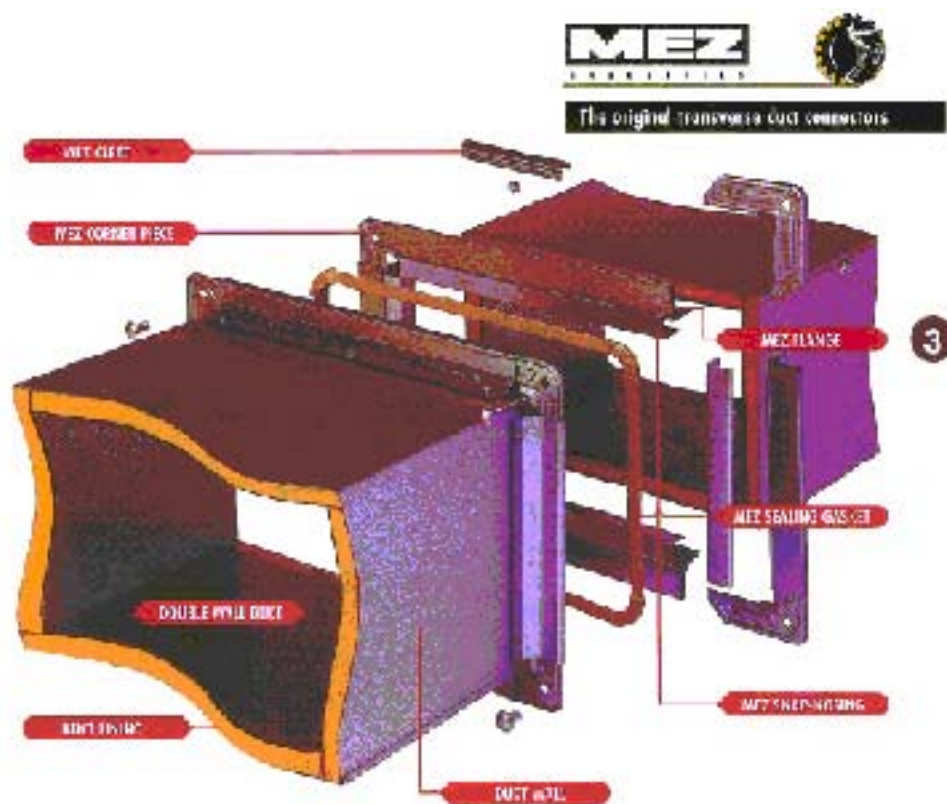

Figure 4-9: Flanged Duct System as Manufactured by Duro-Dyne Corporation

4.7.7 References

ASHRAE. 1998. *ASHRAE Standard 111-1998, Practices for Measurement, Testing, Adjusting, and Balancing of Building Heating, Ventilation, Air Conditioning, and Refrigeration Systems*. American Society of Heating, Refrigeration, and Air Conditioning Engineers.

Delp, W.P., Matson, N.E., Tschudy, E., Modera, M. P., and Diamond, R.C., 1997, “Field Investigation of Duct System Performance in California Light Commercial Buildings.” LBNL Report, LBNL-40102.

Fisk, W.J., Delp, W., Diamond, R., Dickerhoff, D., Levinson, R., Modera, M., Namatollahi, M. and Wang, D., 1998, "Duct Systems in Large Commercial Buildings: Physical Characterization, Air Leakage, and Heat Conduction Gains", LBNL Report, LBNL-42339.

Hamilton, L.N., 2002, Personal Communication, HVAC Consultant.

Modera, M.P., 2002, Personal Communication, AeroSeal, Inc.

Modera, M., Xu, T., Feustel, H., Matson, N., Huizenga, C., Bauman, F., Arens, E., and Borgers, T., 1999, "Efficient Thermal Energy Distribution in Commercial Buildings", LBNL Report, LBNL-41365.

Sherman, M. and Walker, I., 1998, "Catastrophic Failure of Sealants", *Home Energy Magazine On-Line*, August. Available at: www.homeenergy.org/898ductape.textc.html .

Xu, T.T., Carrie, R.F., Dickerhoff, D.J., Fisk, W.J., McWilliams, J., Wang, D., and Modera, M.P., 2000, "Performance of Thermal Distribution Systems in Large Commercial Buildings", LBNL Report, LBNL-44331.

Xu, T.T., Modera, M.P. and Carrie, R.F., 2000, "Performance Diagnostics of Thermal Distribution Systems in Light Commercial Buildings", LBNL Report, LBNL-45080.

4.8 Liquid Desiccant Air Conditioners

4.8.1 Summary

Liquid desiccant dehumidifiers are a type of thermally activated cooling system, where moisture is absorbed from air into a liquid desiccant solution (removing the latent heat) and a thermal input (e.g. from gas firing) supplies the heat of vaporization needed to regenerate the desiccant solution by evaporating the absorbed moisture from the solution. When applied as a packaged make-up air pre-cooling unit that removes the latent portion of the load, the interior air cooling system can operate as a sensible-only cooling system, at higher CFM per ton and high EER. With double-effect regeneration, thermal COPs of 1.2 to 1.4 are feasible.

Table 4-19: Summary of Liquid Desiccant Air Conditioner Characteristics

Characteristic	Result	Comments
Technical Maturity	New/advanced	Estimated 3 –4 years to commercialization, if development and commercialization were pursued vigorously
Systems Impacted by Technology	In principle, all air conditioning systems	Most compatible with installations already using evaporative cooling
Readily Retrofit into Existing Equipment/Buildings?	Depends	More readily for ventilation make-up air systems, less so for complete cooling system. Retrofit issues include space constraints, providing utilities (fuel, flue vents, and cooling water)
Relevant Primary Energy Consumption (quads)	1.3 / 0.3 quads	All non-individual cooling / OA cooling; both for non-individual systems
Technical Energy Savings Potential (quads)	0.2 / 0.06 quads	Split: relative to no DOAS / relative to conventional DOAS.
Approximate Simple Payback Period	~5-6 Years	Based on Lowenstein (1998, 2000) \$385/ton manufacturing cost estimate
Non-Energy Benefits	Improved humidity control and occupant comfort	Removes humidity from ventilation make-up air, stabilizing indoor humidity levels. Low humidity in ducts deters mold and bacterial growth. Relative to air conditioning systems, liquid desiccant systems can remove a much larger portion of latent load for same-size units, providing a comfort benefit in high-humidity applications. The scavenging action of liquid desiccants also removes microbial contaminants from the air to improve IAQ. Liquid desiccant systems also eliminate the need for co-location of air inlet and outlet required by energy recovery for makeup air treatment.
Notable Developers/Manufacturers of Technology	AIL Research, Inc., RNGTech., NREL, Drykor (Israel), U. Florida, Kathabar	AIL Research, Inc. (Ongoing research to build scale “proof of concept” models). The Solar Energy and Energy Conversion Laboratory at the University of Florida has worked on solar-assisted liquid desiccant air-conditioners. Kathabar supplies liquid desiccant dehumidifiers for industrial drying and humidity control applications
Peak Demand Reduction	Yes	Removes some or all of air conditioning load from the electric grid. Devices that produce and store regenerated desiccant during off-peak for on-peak de-humidification would also realize peak demand reductions.
Most Promising Applications	Ventilation make-up air dehumidification/precooling in buildings where an exhaust air stream is not available for energy recovery ventilation, e.g., food service. Buildings with humidity and/or condensation issues, e.g., supermarkets and skating rinks, in humid climates.	
Technology “Next Steps”	Design studies around dedicated humid climate make-up air preconditioning unit. Prototype development and test; address liquid carryover issue	

4.8.2 Background

A liquid desiccant air conditioner removes moisture and latent heat (and, possibly, sensible heat) from process air via a liquid desiccant material, such as lithium chloride. It consists of two primary units, an absorber where concentrated liquid desiccant solution absorbs moisture from the process air, and a regenerator where the moisture taken on by the liquid desiccant in the absorber is removed from the liquid desiccant, thus regenerating the liquid desiccant to the higher concentration. Regeneration requires heat input, so liquid desiccant systems are a thermally activated cooling option. Current commercial applications of liquid desiccant dehumidification are limited to industrial applications where deep drying and/or precise humidity control are needed. Several different configurations have been proposed.

In the basic configuration, shown in Figure 4-10, concentrated and cooled (by a cooling tower or chiller) liquid desiccant flows into the absorber and down through a packed bed of granular particles (or over some other type of enhanced mass transfer surface or packing) where it absorbs moisture and heat from the counter-flowing process air. As the air passes up through the bed, it transfers both moisture and heat to the counter-flowing liquid desiccant. The heat of vaporization of the water vapor that is absorbed is released into the absorbent solution as sensible heat. Eventually, the liquid desiccant leaves the bottom of the packed bed with its concentration reduced by the water absorbed from the air and feeds into the regenerator. In the regenerator, a heat source (be it gas or oil-fired, waste heat, or solar) heats up the weak liquid desiccant solution, which is then sprayed through another packed bed. The heated solution enables mass transfer of the absorbed moisture to a counter-flowing scavenger air stream, removing the moisture from the stream and regenerating a more concentrated liquid desiccant solution. A return feed from the absorber to the aforementioned cooling tower or chiller cools the liquid desiccant solution to a temperature appropriate for the absorber and completes the cycle. A counterflow heat exchanger between the absorber and the regenerator preheats and precools the liquid desiccant solution as it passes from the absorber to the regenerator and then back to the absorber to reduce required external heating and cooling. Two significant performance limitations of this basic arrangement cause the efficiency to be well below levels that would be of interest for HVAC applications – the build up of heat in the absorber reduces the amount of net sensible and latent cooling accomplished by the absorber, and single-effect regeneration only utilizes the regeneration heat input once, inherently limiting the COP to less than 1.

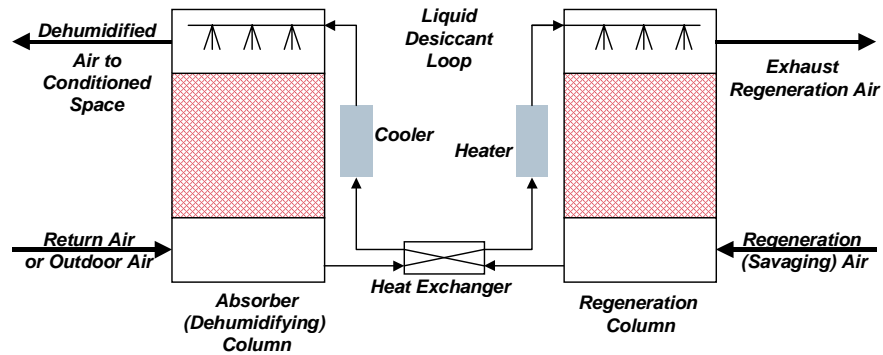

Figure 4-10: Basic Configuration of a Desiccant Dehumidifier

There are many variations on the basic arrangement shown in Figure 4-10. Of the more complex/advanced variants, Figure 4-11 illustrates an arrangement that overcomes one of the major limitations of the basic configuration. The fundamental enhancement of this arrangement is that the absorber is evaporatively cooled (approaching to within several degrees of the outdoor ambient wet-bulb temperature). Evaporatively cooling the absorber allows for a lower air outlet temperature, by transferring the latent heat from the absorbed moisture to ambient air, along with some of the sensible heat of the process air. Figure 4-12 illustrates one configuration of a multiple effect (double-effect is illustrated) regenerator. With multiple effect regeneration each unit of heat input is used to remove two or more units of latent heat from the desiccant solution in the regenerator, increasing the potential COP to more than 1.

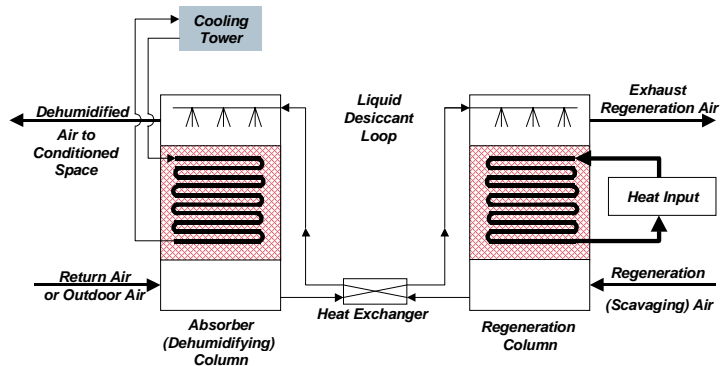

Figure 4-11: Desiccant Air Conditioner with Evaporatively-Cooled Absorber

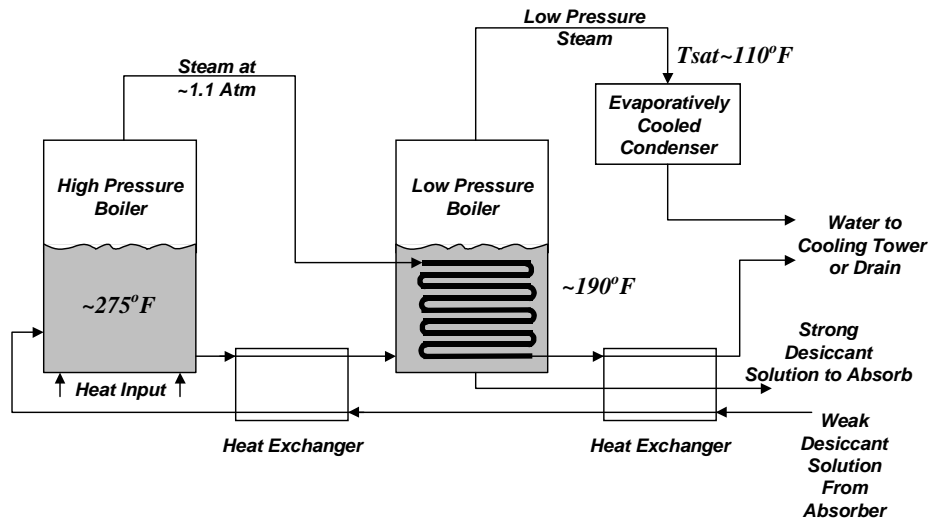

Figure 4-12: Double-Effect Regenerator

Liquid desiccant air conditioners offer the possibility for significant performance gains relative to standard active desiccant wheel systems when they employ multiple-effect boiler regenerators to drive off moisture and re-concentrate the solution. In addition, high-concentration gradient systems may markedly decrease parasitic energy losses. However, existing liquid desiccant air conditioners suffer from two primary problems that limit their performance. First, current systems operate at very low liquid desiccant concentration gradients, which increases the required system mass flow dramatically relative to higher concentration (e.g., a factor of 10). Higher mass flow rates increase parasitic energy consumption, both in terms of liquid desiccant pumping power and also the fan power needed to drive the air through the packed bed. Second, liquid-desiccant air conditioners suffer from desiccant carry-over problems, where the process air entrains liquid desiccant droplets as it passes through the packed bed and desiccant spray, causing potential health concerns and limiting market-acceptance of the devices. Potential solutions to both problems exist. Lowenstein et al. (1998) believes that low-flow rate distribution of the liquid desiccant directly onto the absorber surfaces (i.e., without spraying) can eliminate liquid desiccant carry-over while decreasing the size and cost of the absorber. This approach operates with a stronger desiccant concentration gradient (to uptake more moisture per volume and reduce the liquid desiccant mass flow) and internal absorber cooling to remove the higher heat flux density of the smaller absorber.

4.8.3 Performance

Nationwide, liquid desiccant air conditioners appear to offer little potential for primary energy savings as a wholesale replacement for vapor compression systems unless they utilize waste or solar heat. In humid environments, they will offer some benefits. As discussed below, when used as a means to provide dedicated make-up air precooling and dehumidification, removing the humidity load from the main air conditioning system, overall system energy savings can be obtained. As discussed above, double effect regeneration is needed to obtain competitive performance levels. Lowenstein et al. (1998)

estimate that the COP⁴⁸ for a system employing a double-effect boiler regenerator can approach 1.5. Desiccant systems can make effective use of lower-temperature waste heat (~170°F for single-effect, ~245°F for double-effect; Lowenstein, 1998), making their economics and energy savings more attractive in installations with waste heat available.

A promising application for this technology is preconditioning of ventilation make up air in buildings where an exhaust air stream is not readily available to be utilized for air to air enthalpy exchange with ventilation make-up air. Outdoor air would pass through an evaporatively-cooled absorber, lowering the humidity below the desired indoor RH enough to handle internal moisture loads. The dry bulb temperature of the air would be approximately 10°F above the ambient wet bulb temperature, usually providing a small amount of sensible cooling of the make-up air. At typical design conditions, no sensible cooling is provided to the building, while at lower outdoor wet bulb temperatures, the air delivery temperature is lower and some sensible cooling is provided in addition to the latent cooling capacity. As a result of this make-up air system handling the entire humidity load of the building, the remaining air conditioning load would be all sensible, allowing the air conditioner to be operated at high CFM/ton and an increased evaporating temperature, improving the COP/EER relative to a conventional chiller by about 20% (i.e., the same saving afforded by a DOAS). The air in the conditioned air distribution ducts would have a relative humidity of 70% or less, because the liquid desiccant removes moisture without cooling the air to saturation, allowing the air distribution ducts to be dry, helping to avoid mold and bacterial growth. With a double-effect regenerator, the thermal COP for make-up air dehumidification would be in the range of 1.2 to 1.4, depending on heat and mass transfer surface sizing relative to capacity. Lowenstein (1995) analyzed a make-up air handling system along these lines to be used in a typical office building located in Atlanta. With compact sizing of the components, the estimated COP was 1.2. As such, the primary energy COP of a double-effect regenerated desiccant system is comparable to a vapor compression cycle chiller; triple-effect regeneration could obtain savings of 20 to 25%.

Relative to a conventional DOAS, the liquid desiccant system also saves energy, although it is less than compared to a non-DOAS system. The conventional DOAS uses a chilled water coil to cool the incoming outdoor air to a low enough dew point temperature. In the process, a significant amount of sensible cooling is delivered to the space. A liquid desiccant-based DOAS uses the desiccant to reduce humidity to the required level, but delivers the air at a temperature close to the outdoor wet bulb temperature. At typical design conditions, no sensible cooling is provided to the building, while at lower outdoor wet bulb temperatures, the air delivery temperature is lower and some sensible cooling is provided in addition to the latent cooling capacity. Although the primary energy COP of a double-effect regenerated desiccant system is comparable to a vapor cycle chiller (no savings generated), it does save energy by transferring the sensible load for cooling outdoor air to the higher COP⁴⁹ sensible-only cooling. More importantly, on days when the outdoor wet bulb temperature approaches the chilled water temperature, the liquid desiccant system

⁴⁸ Assumes a gas AFUE of about 80% of HHV.

⁴⁹ By virtue of the higher evaporator temperature

will also contribute a large degree sensible cooling for the outdoor air. The contribution to the savings from each of these effects varies with climate. For an average, Middle Atlantic States climate, a rough estimate is that the energy consumption for conditioning ventilation make-up air is reduced by 25% and the energy for cooling overall is reduced by about 5% (see Table 4-20).

Table 4-20: Liquid Desiccant DOAS Energy Savings DOAS and Conventional Cycle DOAS

Category	Energy Saved [%]	Comments
OA Cooling	20 to 25%	Assumes that: <ul style="list-style-type: none"> • 50% of OA cooling load is sensible • Significant “free” sensible cooling for 50% of OA sensible load
Space Cooling	0%	~10°F increase in space cooling system evaporator temperature; also realized by Dedicated Outdoor Air System

4.8.4 Cost

Lowenstein et al. (1998) estimated a manufacturing cost of \$0.64 per cfm, \$0.77 with single-effect regenerator/absorber versus \$1.20/cfm for a solid-desiccant wheel system; on a manufacturing cost \$/ton basis, a double-effect system would run ~\$385/ton (25-ton system). Lowenstein (2000) more recently verified cost estimate.

4.8.5 Perceived Barriers to Market Adoption of Technology

Sand et al. (1997) notes that “Further improvements are necessary in the efficiency, cost, size, reliability, and life-expectancy to penetrate the broader air conditioning market.” Liquid carry-over (i.e., transport of the liquid desiccant droplets out of the systems and into the circulating air) has proved a difficult problem in the past; NREL (2001) notes that researchers have developed laboratory systems. The LiCl used in many systems tend to corrode metal components and requires design modifications.

4.8.6 Technology “Next Steps”

Design studies around dedicated humid climate make-up air preconditioning unit. Investigate feasibility of triple-effect regeneration. Prototype development and test; address liquid carryover issue. Development of more efficient systems; field testing of systems.

4.8.7 References

Collier, R.K., 1997, "Desiccant Dehumidification and Cooling Systems: Assessment and Analysis", Final Report to Pacific Northwest National Laboratories, PNNL-11694, September.

Lowenstein, A. and Novosel, D., 1995, "The Seasonal Performance of a Liquid-Desiccant Air Conditioner", *ASHRAE Transactions*, Volume 101, Part 1, pp.679-686, January.

Lowenstein, A., 1998, "Advanced Commercial Liquid-Desiccant Technology Development Study", NREL Report NREL/TP-550-24688, November.

Lowenstein, A., 2000, Personal Communication, AIL Research.

NREL, 2001, “NREL’s Advanced HVAC Project: Research to Reduce Energy Use & Cost”, *EnergySolutions, Spring*. Available at:
<http://www.nrel.gov/desiccantcool/pdfs/ess01nrel.pdf> .

Sand, J.R., Fischer, S.K., and Baxter, V.D., 1997, “Energy and Global Warming Impacts of HFC Refrigerants and Emerging Technologies,” Report prepared by Oak Ridge National Laboratory for the Alternative Fluorocarbons Environmental Acceptability Study (AFEAS), U.S. Department of Energy.

4.9 Microchannel Heat Exchangers

4.9.1 Summary

Energy savings can be achieved through the use of microchannel heat exchangers. A scenario summarized in Table 4-21 below shows improvement of performance for an already-efficient 7.5-ton 11EER rooftop unit. An EER boost of up to 1.2 was shown to be possible for this unit without increasing chassis size. The payback period for the improvements is calculated to average about 2 years, assuming U.S. average climate and the relatively conservative supply chain markup of 2.5 from manufacturing cost to end-user cost. This analysis assumes a somewhat unfavorable manufacturing scenario for the microchannel heat exchangers: replacement of OEM-fabricated conventional heat exchangers with microchannel heat exchangers supplied by a vendor. In contrast, it is estimated that payback period for a similar increase in unit efficiency would be 1.5 to 3 times longer if conventional heat exchangers of larger size were used.

Table 4-21: Summary of Microchannel Heat Exchanger Characteristics

Characteristic	Result	Comments
Technical Maturity	Current	Used extensively for automotive air-conditioning and in some stationary air-conditioning applications
Systems Impacted by Technology	Unitary (Packaged) Cooling	Used for air-cooled condensers and air-cooling evaporators.
Readily Retrofit into Existing Equipment/Buildings?	No	
Relevant Primary Energy Consumption (quads)	1.0	Potentially all vapor compression cooling excluding water-cooled chillers.
Technical Energy Savings Potential (quads)	0.11	~10% cooling energy savings estimate (based on estimate from Table 4-23 showing EER improvement from 11.5 to 12.7)
Approximate Simple Payback Period	2 Years (for unitary)	Payback period is strongly dependent on the way the technology is implemented.
Non-Energy Benefits	More compact equipment, reduced weight, reduced refrigerant charge, improved evaporator latent capacity, enhanced corrosion resistance (and less performance impact due to corrosion)	
Notable Developers/Manufacturers of Technology	Modine	A number of companies including Modine supply automotive OEM's. HVAC OEM's have investigated the technology but have not commercialized it in their products. Furthermore, some companies such as Heatcraft are investigating and/or developing the technology for stationary HVAC applications.
Peak Demand Reduction	Yes	
Most Promising Applications	Air-cooled systems for space-constrained applications, in particular rooftop air-conditioning units, air-cooled chillers, air-cooled condensers and condensing units.	
Technology "Next Steps"	Monitor the progress, particularly by Modine, in selling microchannel heat exchangers to AC manufacturers and provide assistance if appropriate	

4.9.2 Background

Microchannel heat exchangers consist of flat microchannel tubes connected in parallel between two headers and fan-fold fins with louvers brazed between adjacent tubes. Microchannel heat exchanger construction is compared with that of conventional heat exchangers in Figure 4-13 below. The flat microchannel tubes are connected to headers at the ends of the heat exchanger and serpentine or fan-fold fins are placed between the tubes. Microchannel heat exchangers are fabricated out of aluminum which is anodized in locations required for brazing. They are assembled out of their constituent components and brazed in a brazing oven. For most AC applications, the high pressure drop through a single microchannel tube makes use of parallel circuiting necessary. The sophisticated techniques required for fabricating these heat exchangers cost-effectively have been developed over years by Modine and have been emulated by a few other manufacturers. For the

conventional heat exchanger, the fins are continuous sheets with holes through which the tubes can pass. The hairpin tubes are slid through the holes, and the open tube ends are connected as required using return bends, headers, etc.

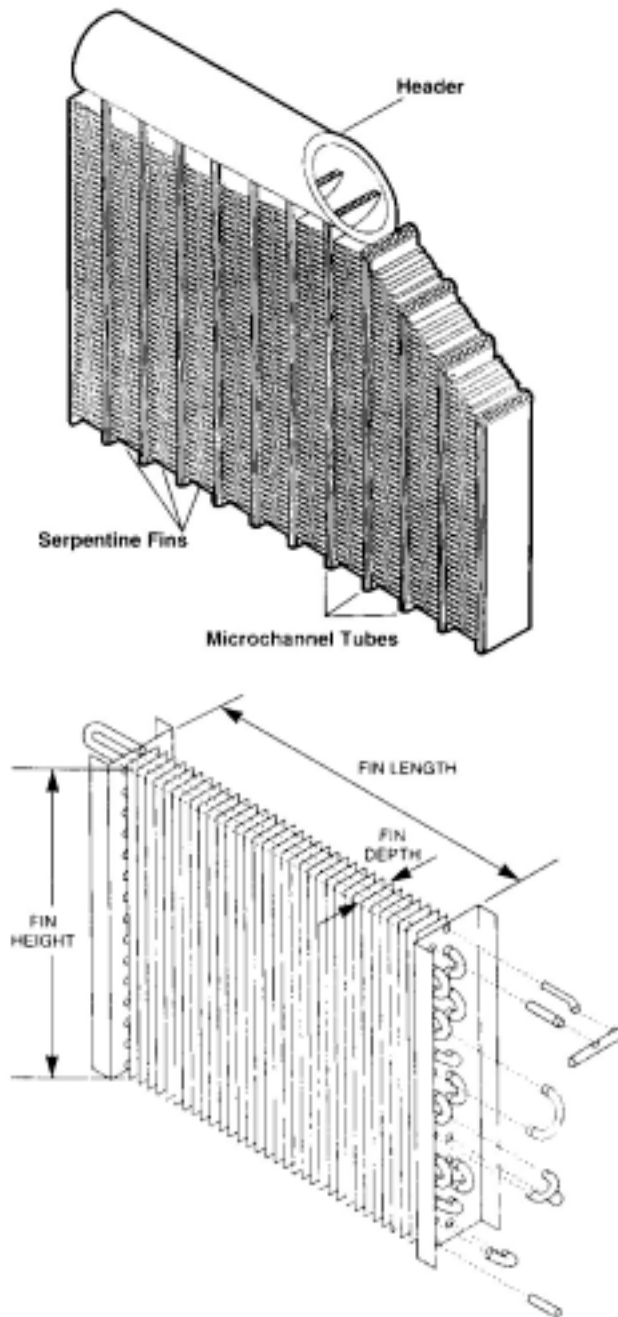

Figure 4-13: Microchannel and Conventional Heat Exchanger Comparison

Currently, microchannel heat exchangers are used extensively for automotive air-conditioning. The technology has been discussed within the stationary HVAC industry for

many years but has enjoyed limited success to date. Major manufacturers reportedly concluded based on past investigation that the technology did not provide enough cost benefit over conventional heat exchanger technology.

Microchannel heat exchangers provide improved heat transfer as compared to conventional heat exchangers due to: (1) the small refrigerant flow passages result in high refrigerant-side heat transfer, and (2) the flat orientation of the tubes reduces airside flow resistance, leading to either increased air flow or reduced fan power either of which can improve overall system efficiency.

Additional benefits include the following:

- Microchannel heat exchangers have significantly lower internal volume, resulting in lesser refrigerant charge.
- The high refrigerant-side heat transfer of microchannel evaporators results in lower fin surface temperatures, which boosts latent capacity.
- The smaller size and lesser weight of microchannel heat exchangers allows for more compact system design.
- Improved corrosion resistance and reduced likelihood of performance reductions resulting from corrosion.

Some drawbacks and challenges to successful use of microchannel technology include the following:

- Typical use of copper tubing for piping between refrigeration circuit components will lead to aluminum/copper joints at the heat exchangers. Technologies for connecting these different metals are not as well known as copper brazing, and the joint must be protected from galvanic corrosion. The currently recommended technology is compression ring fittings which mechanically seal the tubes. The fittings manufactured by Lokring are the most well known (see Figure 4-14 below).
- Repair of leaks in conventional heat exchangers by brazing can be considered by experienced technicians, whereas repair of a leak in a microchannel heat exchanger generally requires replacement.
- There is greater design flexibility in conventional heat exchanger technology. For instance, it is much easier to design a condenser with a separate subcooling circuit, or to arrange an evaporator in parallel or counter flow with the air.



Figure 4-14: Compression Ring Fitting for Connection of Aluminum Heat Exchangers to Copper Tubes

4.9.3 Cost

The impact on system cost of microchannel heat exchangers is dependent not only on the cost associated with the heat exchanger, but also on the cost impacts of the following potential changes.

- Cost impact must be evaluated based on well-defined and detailed comparisons. Some possible scenarios are equal performance, equal cost, some performance improvement with some cost change. While microchannel technology could potentially be used to provide equal performance at reduced cost, the intent of the analysis described in the next section is to show performance improvement with allowance for cost increase.
- Reduced heat exchanger size and weight resulting in a smaller and lighter system can result in significant cost benefit. As mentioned, investigation of this possibility is not the intent of the described analysis.
- Reduced airside pressure drop could result in a reduction in fan or blower costs. This will have a greater likelihood of having an impact for microchannel condensers. The cost of a lower-performance fan blade may not have much effect on cost, but use of a smaller fan guard and especially use of a smaller motor may make a significant effect.

The first of the above points must be addressed carefully when attempting to assess the cost impact of microchannel heat exchanger technology. The manufacturing scenario must also be carefully considered. For instance, a large HVAC system manufacturer most likely manufactures its own heat exchangers, whereas small manufacturers may purchase heat exchangers from vendors. The transition to a new heat exchanger technology would have very different economics for these two manufacturing scenarios.

4.9.4 Performance

A cost benefit trade off analysis was prepared based on the Carrier 48HJ-008 rooftop unit. Key data for the baseline unit are summarized in Table 4-22 below.

Table 4-22: Baseline Rooftop Unit Summary Data

Rated Performance	
Capacity (tons)	7.5
EER	11.0
Compressor	Copeland ZR42K3-TF5
Refrigerant	HCFC-22
Refrigerant Charge (pounds)	15.75
Condenser	
Face Dimensions (Height x Width, inches)	36 x 82
Tube Rows (High x Deep)	36 x 2
Tubes	3/8" OD, Rifled, 0.012" Wall
Fins	Double Wavy, 0.0045" Thick Alum, 17FPI
Air Flow (cfm)	7,000
Fans	Two 22-inch Dia, 3-blade, 20° Blade Angle
Fan Motors	1,140 rpm, 1/4hp each
Fan Motor Power Input	325W each
Evaporator	
Face Dimensions (Height x Width, inches)	32 x 40
Tube Rows (High x Deep)	32 x 3
Tubes	3/8" OD, Rifled, 0.012" Wall
Fins	Lanced, 0.0045" Thick Alum, 15FPI
Blower Motor Power Input (for ARI capacity test)	900W

Both the baseline unit performance and performance for a number of system configurations involving microchannel heat exchangers were examined. Results are summarized in Table 4-23 below. Note that modeled EER of the baseline unit was better than the rated 11.0 EER. Performance predictions for the microchannel heat exchangers were provided by Modine. Performance projections for the conventional heat exchangers were made based on Heatcraft's performance prediction program and performance prediction for the conventional condensers was confirmed by Modine.

Table 4-23: Performance Comparison of Baseline Rooftop Unit and Modified Units Using Microchannel Heat Exchangers

Number		1	2	3
Model Summary	Baseline	A) Equal Face Area Coils B) Set Evap. Air Flow for Same Evap. Temp. as Baseline	Same as #1, different condenser	Same as #1, different evaporator
Compressor	Baseline	Baseline	Baseline	Baseline
Condenser	Baseline (17FPI)	20 FPI PF TM	22 FPI PF TM	20 FPI PF TM
Face Area (sqft)	20.5	20.5	20.5	20.5
Air Flow (cfm)	6,500	7,000	6,940	7,000
Condenser Fan	Baseline	Baseline	Baseline	Baseline
Evaporator	Baseline (15FPI)	12 FPI PF TM	12 FPI PF TM	14 FPI PF TM
Air Flow	3,000	3,041	3,054	2,806
System Parameters				
Cond. Temp (°F)	115.0	114.7	114.2	114.7
Evap. Temp (°F)	47.0	47.0	47.0	47.0
Power Input (W)				
Indoor Blower	900	835	844	710
Cond. Fans	650	542	542	542
Compressor	6,308	6,280	6,238	6,280
Performance				
Capacity (Btu/hr)	90,225	91,486	91,741	91,937
SHR	74%	71%	71%	70%
EER (Btu/hr-W)	11.5	11.9	12.0	12.2
Manufacturing Cost Premium		\$93	\$93	\$93
Energy Cost Savings		\$37	\$46	\$64
End-User Payback Period (years)		6.2	5.1	3.7

Number	4	5	6	7
Model Summary	Same as #3, but increase evaporator air flow to 3,000	Same as #3, but increase condenser air flow	Same as #5, But smaller compressor	Same as #6, But 3,000 cfm evap. Air flow to boost capacity
Compressor	Baseline	Baseline	ZR40K3-TF5	ZR40K3-TF5
Condenser	20 FPI PF™	20 FPI PF™	20 FPI PF™	20 FPI PF™
Face Area (sqft)	20.5	20.5	20.5	20.5
Air Flow (cfm)	7,000	8,250	8,250	8,250
Condenser Fan	Baseline	Increase blade angle to 24°	Increase blade angle to 24°	Increase blade angle to 24°
Evaporator	14 FPI PF™	14 FPI PF™	14 FPI PF™	14 FPI PF™
Air Flow	3,000	2,861	2,641	3,000
System Parameters				
Cond. Temp (°F)	114.7	112.5	111.7	111.7
Evap. Temp (°F)	47.7	47.0	47.0	48.2
Power Input (W)				
Indoor Blower	835	744	613	834
Cond. Fans	542	758	758	758
Compressor	6,272	6,102	5,762	5,754
Performance				
Capacity (Btu/hr)	92,781	92,975	88,775	90,157
SHR	70%	70%	70%	71%
EER (Btu/hr-W)	12.1	12.2	12.4	12.3
Cost Premium	\$93	\$93	\$93	\$93
Energy Cost Savings	\$54	\$63	\$80	\$71
End-User Payback Period (years)	4.3	3.7	2.9	3.3

Number	8	9	10
Model Summary	Same as #7, But larger condenser	Same as #8, but reduce evaporator air flow	Baseline with condenser change only
Compressor	ZR40K3-TF5	ZR40K3-TF5	Baseline
Condenser	20 FPI PF™	20 FPI PF™	20 FPI PF™
Face Area (sqft)	24	24	20.5
Air Flow (cfm)	8,250	8,250	7,000
Condenser Fan	Increase blade angle to 23°	Increase blade angle to 23°	Baseline
Evaporator	14 FPI PF™	14 FPI PF™	Baseline
Air Flow	3,000	2,800	3,000
System Parameters			
Cond. Temp (°F)	111.3	111.2	114.5
Evap. Temp (°F)	48.2	47.6	46.4
Power Input (W)			
Indoor Blower	834	705	900
Cond. Fans	650	650	542
Compressor	5,722	5,720	6,269
Performance			
Capacity (Btu/hr)	90,358	89,781	90,305
SHR	71%	70%	75%
EER (Btu/hr-W)	12.5	12.7	11.7
Cost Premium	\$130	\$130	\$40
Energy Cost Savings	\$88	\$104	\$19
End-User Payback Period (years)	2.6	2.2	5.3

Additional explanation of assumptions appears below:

- 1) Microchannel heat exchanger costs were based on an estimate provided by Modine of \$385 for equal-face-area PFTM heat exchangers. This is a conservative estimate, assuming that production of these heat exchangers ramps up to reasonable levels. The key caveats regarding this cost are: (a) the condenser and evaporator consist of two separate heat exchangers, since it is not yet clear whether fabrication capabilities will allow for them to be constructed as single units, and (b) this cost assumes the coils are purchased from a supplier rather than fabricated by the OEM.
- 2) Conventional heat exchanger cost estimates developed by TIAX (2002) were based on production levels typical for Carrier. The cost estimate is \$276 for both the evaporator and condenser. The scenario assumes that the air-conditioning unit manufacturer fabricates the heat exchangers (as is typical for Carrier), rather than purchasing them from a supplier, as is assumed for the microchannel scenario.
- 3) Refrigerant quantity for the system using microchannel heat exchangers will be reduced by about 50%. The 8lb refrigerant savings represents \$16 cost savings assuming \$2/lb OEM cost for HCFC-22.
- 4) The increased face area condenser can be designed for a unit with no footprint change, due to the ability to bend the microchannel heat exchangers more easily than conventional heat exchangers. The fairly modest (17%) face area change makes a significant EER improvement. An estimate of added heat exchanger cost for the larger is \$20.
- 5) The conventional evaporator has short-tube orifices incorporated within them. No additional cost is assumed for an expansion device for the microchannel evaporator, because it is assumed that short-tube orifices can be incorporated in it as well at negligible cost.
- 6) Cases 5 through 10 involve condenser fans with higher-angle blades, and Cases 5 through 7 potentially involve larger motors. The higher-angle blade should not affect cost, but the larger motors may result in additional cost increase.
- 7) The cost savings for the smaller compressor will be very small. It is probably within the uncertainty range of the heat exchanger cost premium estimate.
- 8) Energy Cost Savings are annual, assuming that the equivalent-full-load hours of operation of the unit is 2,000 hours, which is average for the U.S. Using the performance, baseline energy use is 15,691 kWh. An average energy cost of \$0.070/kWh is assumed, and the EER reduction is assumed to be representative of the seasonal energy use reduction.
- 9) End User Payback Period is calculated assuming a markup of costs from the manufacturer to the end user of 2.5. This markup has been used throughout this report in order to preserve consistency between cost estimates for different energy saving options. However, deviations of actual markup from this value will result in different calculated payback periods. For instance, if the markup were 2.0 rather than 2.5, the payback period for Case 9 of Table 4-23 would be 1.8 rather than 2.2.

As a basis of comparison for the cost/benefit ratio for a system modified through the use of microchannel heat exchangers, ongoing analysis (TIAX, 2002) for commercial air-

conditioning equipment shows that comparable efficiency boost costs more with conventional heat exchanger technology. The analysis suggests that an increase in EER from 11 to 12 for a 7.5-ton rooftop unit would cost from \$150 to \$260, depending on whether the chassis size must be increased for the particular model.

This scenario summarized above is illustrative of the potential for microchannel heat exchanger energy savings. However, it should be noted that savings potential may be different for other units, depending on their design detail. In particular, the savings would likely have been greater if the baseline unit EER was 9 or 10 rather than 11. Savings potential would be different for different products, such as air-cooled chillers. The analysis presented above was itself not exhaustive in evaluating the different options which could be considered. However, some key observations regarding the analysis are as follows:

- 1) The analysis shows that EER can be boosted by up to 1.2 with the given unit chassis.
- 2) This improvement in efficiency was achieved at a very reasonable cost premium of \$93 in manufacturing cost, much less cost than would be incurred if conventional heat exchangers of larger size were used to provide comparable performance improvement.
- 3) Simple Payback period for average U.S. climate is down to about 2 years. Economic attractiveness would be better in warmer climates. For instance, in Texas, effective full load hours would be roughly 3,000, and payback period would reduce to about 1.3 years.
- 4) Reduction in indoor blower power due to evaporator pressure drop reduction can contribute to EER improvement as much as condenser fan power reduction. Case 10 (condenser change only) increased EER by 0.2, while swap of both heat exchangers (Case 1) increased EER by 0.4.
- 5) Using higher fin density was more beneficial for the microchannel evaporator, if air flow can be reduced as a result. This appears to be because (a) the heat exchanger pressure drop is a lesser percentage of total airside pressure drop for the evaporator, and (b) blower power reduction boosts capacity as well as decreasing input power.
- 6) The best results require a system analysis, including additional system changes besides simply swapping heat exchangers.
- 7) The sensible heat ratio predicted for the microchannel heat exchangers is consistently lower, reflecting greater latent capacity capability.

4.9.5 Perceived Barriers to Market Adoption of Technology

As mentioned above, microchannel heat exchanger technology has been discussed as a way to improve performance or efficiency for stationary HVAC equipment for many years. In past investigation of the technology, equipment manufacturers concluded that microchannel technology would not be cost-effective.

Capital costs associated with entering into production of microchannel heat exchangers is certainly an issue. Another issue is technical risk. Successful manufacture of microchannel heat exchangers is not as straightforward as for conventional heat exchangers.

Another barrier to adoption of microchannel heat exchanger technology is the need for accurate performance prediction tools. The improvement of prediction tools was the subject

of an ARTI research program recently (Jacobi et al., 2001). The public availability of the final report of the first phase of this study may give some manufacturers greater confidence in moving ahead with use of microchannel technology. However, the information is not easily useable for design purposes, i.e. as a computer program with easy user interface.

4.9.6 Technology Development “Next Steps”

- Development of publicly-available performance prediction tools.
- Investigate approaches for microchannel heat exchanger fabrication cost reduction.
- Develop fabrication techniques which allow for greater design flexibility.

4.9.7 References

Jacobi, A.M., Y.Park, D.Tafti, and X.Zhang, 2001, “An Assessment of the State of the Art, and Potential Design Improvements, for Flat-Tube Heat Exchangers in Air Conditioning and Refrigeration Applications—Phase I”, ARTI-21CR Project 20020-01 Final Report, September.

TIAX, 2002, Internal Preliminary Assessment of Energy Savings Potential Using Conventional Heat Exchanger Technology, May.

4.10 Microenvironments (Task-Ambient Conditioning)

4.10.1 Summary

Microenvironments, also called task-ambient conditioning, is an idea that has been commercialized in Japan, Europe, and the United States for more than ten years. While modest to moderate energy savings are possible in commercial buildings, task-ambient conditioning systems are best known for increasing the thermal comfort of workers in open plan office spaces. Major barriers such as high initial cost and resistance to moving away from traditional room air distribution systems have hindered task-ambient conditioning from achieving widespread adoption in the U.S. commercial office building market. Education efforts may produce some increased interest in the benefits of task-ambient conditioning.

Table 4-24: Summary of Microenvironments Characteristics

Characteristic	Result	Comments
Technical Maturity	Current	<i>Limited adoption despite commercialization in the 1980s and early 1990s.</i>
Systems Impacted by Technology	All HVAC systems (except individual) in office buildings	
Readily Retrofit into Existing Equipment/Buildings?	No	Task-ambient conditioning typically requires significant ductwork changes in retrofit installations to tap into the overhead plenum supply duct or change to an under-floor supply. (For installations that already have under-floor air supply, task-ambient systems <u>are</u> readily retrofit.)
Relevant Primary Energy Consumption (quads)	0.55	All cooling and supply and return fan energy (except individual) in office buildings
Technical Energy Savings Potential (quads)	0.07 ⁵⁰	Includes energy savings associated with cooling equipment and fans (does not include lighting energy savings) – assumes occupancy sensors are used.
Approximate Simple Payback Period	>100 years	Considering only energy cost savings (not considering the value of any increase in worker productivity).
Non-Energy Benefits	Increased occupant comfort; potentially improved air quality.	
Notable Developers/Manufacturers of Technology	Johnson Controls, Inc. (Personal Environments®); Hartman Company (Uniterm™ - prototype stage); Tate Access Floors, Inc. (Task Air™); Argon Corporation (various models); Interface Architectural Resources (Habistat®); Mikroklimat Sweden AG (Climadesk™); Several Japanese manufacturers; Center for the Build Environment (UC, Berkeley)	
Peak Demand Reduction	Yes	Reduces cooling (and associated ventilation) power draw during peak demand periods (primarily via occupancy sensors).
Most Promising Applications	Open-plan office spaces with intermittently occupied workspaces and low personnel densities (to maximize energy savings); new construction presents more favorable economics for microenvironment conditioning units than retrofits.	
Technology “Next Steps”	No additional steps are necessary.	

4.10.2 Background

Microenvironment conditioning (also called task-ambient conditioning) personalizes thermal conditions (temperature, humidity, and airflow) to maximize thermal comfort. Thermal comfort is a difficult parameter to quantify since it is based on personal preferences of temperature, humidity, and airflow that vary depending on gender, activity level, clothing level, and can even vary day to day depending on a person’s mood or physical condition. Research has statistically quantified “comfort” according to experimental surveys of people working under various conditions, but even a well-designed HVAC system will leave 10% of the occupants “too hot” or “too cold” (CBPD, 1994). According to studies of actual office buildings (e.g., Schiller et al., 1988, from Arens et al., 1991) a much larger portion (~40%) of occupants are dissatisfied with their thermal work

⁵⁰ Much of the cooling savings relative to conventional systems comes from the higher evaporator temperature used to realize the higher air delivery temperatures. In moderately humid climates, such a scheme would necessitate a dedicated outdoor air system (DOAS) to provide humidity management, in which case a significant portion of the savings would be attributed to the DOAS and not microenvironments.

environment. Microclimate conditioning essentially creates a virtual zone for each occupant to control the environment to his or her preference. Several manufacturers offer products that supply air at different locations (floor-mounted, desk-mounted, overhead, and cubicle divider-mounted are the most common) and have different features (some have individual supply fans, radiant heating or cooling panels, masking noise generators, recirculating dampers, integrated lighting control, occupancy sensors, etc. while others do not). Figure 4-15 depicts a desk-mounted system with many features – the Personal Environments® unit by Johnson Controls, while Figure 4-16 shows an in-floor system with few features – the Task Air™ system by Tate Access Floors, Inc. Figure 4-17 shows various units produced by Argon Corporation.

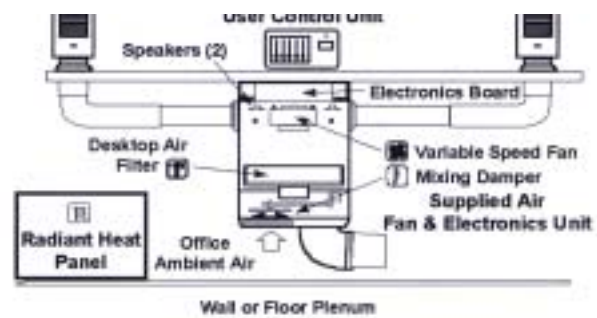
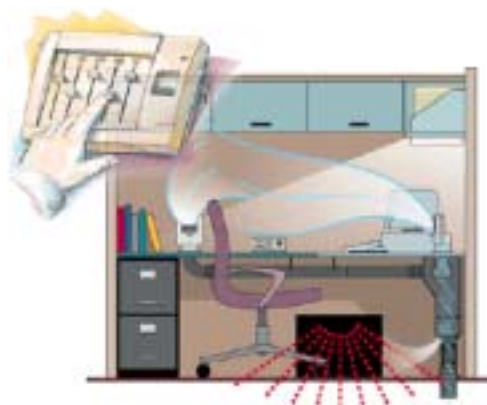

Figure 2: Supplied Air Personal Environments Systems

Figure 4-15: Johnson Controls' Personal Environments® Systems

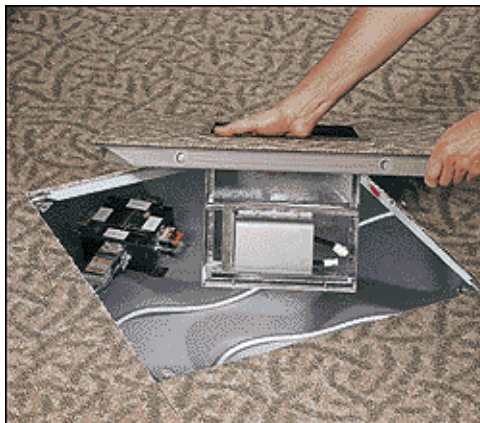

Figure 4-16: Task Air™ by Tate Access Floors, Inc.

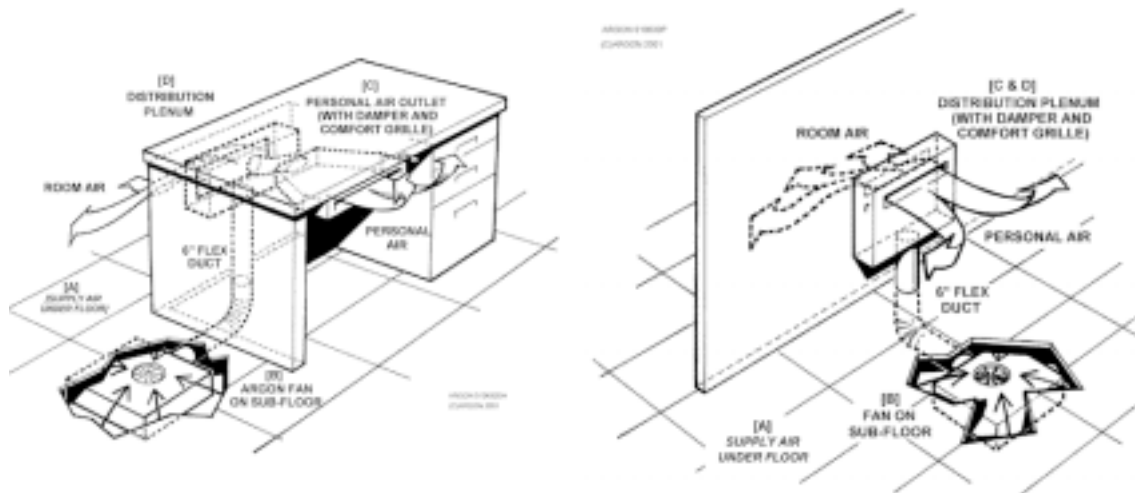

Figure 4-17: Argon Corporation Products (desk-mounted and cubicle-wall mounted)

Microenvironment conditioning potentially affects HVAC energy consumption in several ways; some reduce energy consumption and some increase it. Table 4-25 summarizes the factors affecting HVAC energy. The three primary energy saving factors in all microenvironment systems are:

- Higher cooling supply air temperatures (to avoid “cold blow” directly on occupants), yielding an increased air-conditioning cycle efficiency (COP) (dehumidification concerns, however, limit the increase in supply air temperature) and allowing for more hours of economizer operation in a year;
- The average temperature is allowed to float in common areas – higher (in the cooling season) and lower (in the heating season) – reducing thermal envelope loads (smaller indoor-outdoor temperature difference);
- Occupancy sensor play a large role in limiting the local fan power consumption and also reducing the cooling and heating consumption.

The net effect of microenvironment conditioning, however, will not necessarily be an overall *reduction* in annual energy consumption since task-ambient conditioning systems also increase energy consumed by air distribution equipment.

Table 4-25: Summary of How Microenvironments Affect HVAC Energy

Action of Task-Ambient System	Results	Affect on annual electric consumption of HVAC system in typical commercial buildings
Add local fans to each desk (in parallel with central fans)	Increases the electric draw.	Increase (+++)
	Reduces the static pressure across the central fans.	Decrease (-)
Increase cooling supply air temperature	Increases cycle efficiency (COP) of the air-conditioning equipment	Decrease (--)
	Increases the required airflow rate to meet the thermal loads.	Increase (++)
	Increases the number of hours available for economizing.	Decrease (--)
Decrease heating supply air temperature	Increases the required airflow rate to meet the thermal loads.	Increase (+++)
Increase average room temperature setpoint (cooling) or decrease average room temperature setpoint (heating)	Decreases the required airflow rate to meet the thermal loads.	Decrease (--)
	Reduces thermal envelope loads.	Decrease (-)
Turn system off when unoccupied (occupancy sensors)	Reduces lighting loads	Typically small; varies with building type
	Reduces local fan loads	Decrease (-)
Add radiant heaters to each desk	Increases the electric draw.	Increase (++)
	Reduces the required airflow rate to meet the thermal loads.	Decrease (-)

Several simplifying assumptions of microenvironment systems are made when considering energy savings and costs in the following sections. These assumptions are typical of task-ambient conditioning systems as documented by Bauman et al. (1991 and 1994):

- Cooling supply air is provided at 64°F to avoid draft (compared to 58°F in a conventional system);
- Heating supply air is provided at 100°F to avoid discomfort (compared to 130°F in a conventional system);
- Damper controls allow each user to mix supply air with locally re-circulated air to control the supply temperature;
- Stratification creates return air that is 4.5°F warmer than air in the occupied zone when cooling;
- Room thermostats are allowed a wider throttling range (7°F versus a more conventional 4.5°F);
- Occupancy sensors are included to turn off the fan and radiant heating panel;
- Lighting is *not* considered a part of the system (non-HVAC);
- Other non-HVAC features are also excluded (such as sound masking, etc.).

4.10.3 Performance

Summary: Experiments and simulations have shown that reducing HVAC energy consumption is possible with properly designed, installed, and operated task-ambient

conditioning systems. Increased economizing, stratification within the room, and looser temperature regulation in common areas all contribute to average annual energy savings of 16% for cooling equipment and 4% for fans throughout the U.S., with occupancy sensors accounting for most of the energy savings. Applying these average energy savings over the U.S. office building segment gives a total of 0.07 quads.

Early energy simulation studies (Arens et al. 1991; Seem and Braun, 1992) suggested that the overall annual air-conditioning energy consumption of a microenvironment system is less than that of a conventional system (approximately 20% to 30% depending on climate) because of increased economizing and occupancy sensors (which limited the additional fan power consumption). These studies, however, did not represent specific buildings but made broad generalizations about building characteristics and operation. Subsequent studies have reinforced the energy savings potential of microenvironment systems through detailed simulations and field studies.

A study by Bauman et al. (1994) contains detailed analysis of microenvironment systems in large office buildings⁵¹. By simulating prototypical office buildings in two California cities with DOE-2, Bauman showed that microenvironment systems could decrease annual cooling and distribution energy consumption by up to 18%, with the occupancy sensor accounting for the greatest portion of the energy savings. These savings, however, are under the most optimistic conditions (a larger throttling range for thermostats, significant vertical stratification, and occupancy sensors) and there are cases for which he found increases in energy consumption. Tables 4-26 and 4-27 show a summary of relevant simulation results.

⁵¹ The office buildings are prototypical large office buildings as defined by Huang et al., 1990.

Table 4-26: Summary of the Factors Affecting HVAC Energy in Fresno, CA (from Bauman et al., 1994)

Case	% change
Baseline (with economizer) <ul style="list-style-type: none"> Air supply temperature = 58°F 	N/A
Floor-Mounted Microenvironment Unit <ul style="list-style-type: none"> Economizer 4.5°F stratification between the occupied zone and return air 7°F throttling range allowed by room thermostats Air supply temperature = 64°F 	-11%
Floor-Mounted Microenvironment Unit <ul style="list-style-type: none"> Economizer No stratification between the occupied zone and return air 4.5°F throttling range allowed by room thermostats Air supply temperature = 64°F 	+3%
Desk-Mounted Microenvironment Unit <ul style="list-style-type: none"> Economizer 4.5°F stratification between the occupied zone and return air 7°F throttling range allowed by room thermostats No occupancy sensor Air supply temperature = 64°F 	+0.4%
Desk-Mounted Microenvironment Unit <ul style="list-style-type: none"> Economizer 4.5°F stratification between the occupied zone and return air 7°F throttling range allowed by room thermostats Occupancy sensor Air supply temperature = 64°F 	-13%

Table 4-27: Summary of How Different Microenvironment Systems Impact HVAC Energy in San Jose, CA (from Bauman et al., 1994)

Case	% change
Baseline (with economizer) <ul style="list-style-type: none"> Air supply temperature = 58°F 	N/A
Floor-Mounted Microenvironment Unit <ul style="list-style-type: none"> Economizer 4.5°F stratification between the occupied zone and return air 7°F throttling range allowed by room thermostats No occupancy sensor Air supply temperature = 64°F 	+7%
Desk-Mounted Microenvironment Unit <ul style="list-style-type: none"> Economizer 4.5°F stratification between the occupied zone and return air 7°F throttling range allowed by room thermostats No occupancy sensor Air supply temperature = 64°F 	-5%
Desk-Mounted Microenvironment Unit <ul style="list-style-type: none"> Economizer 4.5°F stratification between the occupied zone and return air 7°F throttling range allowed by room thermostats Occupancy sensor Air supply temperature = 64°F 	-18%

As documented by Bauman et al. (1991), experiments show that a 4.5°F stratification and 7°F throttling range are achievable (while maintaining acceptable comfort conditions) when using desk-mounted task-ambient conditioning systems in open-plan offices, so energy savings of 5% to 18% are possible. In many cases, however, humidity concerns due to the higher air supply temperature (64°F) would impact the system design. Specifically, in climates with even a handful of humid days, a dedicated outdoor air system (DOAS) would be essential to prevent moisture problems from developing. In such climates, the microenvironments would still realize energy savings from occupancy sensors but the DOAS would account for a portion of the energy savings. If microenvironment systems in moderately humid climates did not use a DOAS to manage humidity, they would require more conventional (lower) evaporator temperatures and potentially reheat to achieve the desired (higher) air delivery temperatures, compromising the energy savings potential.

The mild climate of San Jose allows more economizer operation than in Fresno, thus the energy savings potential is greater. Fresno’s results are more typical of other cities in the U.S. because the increase in economizing is not as substantial, as suggested by simple binned-load calculations performed for this study⁵². Table 4-28 shows the results of applying Fresno’s results (Fresno – desk-mounted system with occupancy sensor, from Table 4-26) across the U.S. commercial office building market.

Table 4-28: Total Energy Savings Potential of Microenvironments in U.S. Office Buildings

Case	Cooling Equipment	Supply and Return Fans
Total Annual Energy Consumption	0.40 Quads	0.16 Quads
Potential Energy Savings (%)	16%	4%
Potential Energy Savings	0.06 Quads	0.006 Quads
Total	0.07 Quads	

On the other hand, heating energy savings are not clearly reported and some discussion by Bauman indicates that microenvironment systems can increase the energy consumed for heating. Floor and desk-mounted air supplies can cause “cold feet”, prompting occupants to keep their units at desk level and also prompted Johnson Controls to install a floor-level electric-resistance radiant heater in its units. If electric-resistance radiant heating became the norm for microenvironment systems, they would almost certainly cause the systems to have a net increase in primary energy consumption. Placing air distribution vents at the floor and desk levels would seem to alleviate the need for a separate electric resistance heating panel.

4.10.4 Cost

Summary: Depending on the complexity of a system installed costs range between \$500 and \$1,300 per system (e.g., desk). Considering optimistic energy cost savings, only, gives a simple payback periods that exceed 100 years (far exceeding the reasonable lifetime of the equipment). Though a source of debate, manufacturers argue that the value of increased worker productivity reduces the simple payback to approximately 18 months.

⁵² Binned simulation of conventional and task-ambient VAV systems utilizing economizing and considering COP effects for a typical office building in five U.S. cities: Albuquerque, Chicago, Miami, New York, and San Francisco.

Johnson Controls markets a microenvironment unit for cubicles (called Personal Environments®) with an installed cost of the units between \$800 and \$1,300 according to company literature, with the spread reflecting the range of potential features and quantity of units ordered. Other manufacturers, such as Argon Corporation, offer less complex systems at prices as low as \$500, installed.

Based on a simple binned-load analysis⁵³ of five U.S. cities and using an installed system cost of \$5 per square foot (\$500 per unit where each unit occupies 100 ft²), all five cities saw a simple payback over 100 years (see Table 4-29).

Table 4-29: Estimated Simple Payback Periods for Microenvironments in 5 U.S. Cities (based on Energy Savings only)

Case	Electric Rate (\$/kWh)	Annual Electric Savings (kWh/ft ²)	Simple Payback (years)
New York City	0.10	0.43	115
Chicago	0.05	0.50	200
Fort Worth	0.06	0.52	160
Albuquerque	0.06	0.62	135
San Francisco	0.08	0.16	380

Based on a case study investigation by Johnson Controls, a productivity gain of 2.8% resulted (worth ~\$845/year/person), giving a simple payback of ~18 months (Lomonaco and Miller, 1997). Various studies documenting productivity gains are available in the literature (e.g., Fisk, 2000; Wyon, 2000), but there is little agreement as to the accuracy and magnitude of productivity increases.

Microenvironment systems also offer greater flexibility for re-configuration than conventional HVAC systems, particularly when integrated into a raised floor layout. This reduces the cost of re-configuration, potentially improving the economics of microenvironments in higher “churn” applications.

4.10.5 Perceived Barriers to Market Adoption of Technology

First cost represents the most significant barrier – building owners must be convinced that the value of increased occupant comfort is significant to warrant the significant first cost of a task-ambient system. Contractors, builders, and building owners are also reluctant to adopt an unconventional and relatively unproven air distribution system.

4.10.6 Technology “Next Steps”

While additional education may increase the adoption of task-ambient conditioning in the U.S., much work has already been done. Energy and cost estimates have been extensively documented by Bauman et al. (Bauman et al. 1991; 1992; and 1994). Bauman and Arens (1996) have developed practical design guidelines for contractors and builders, outlining how to install task-ambient conditioning systems. Johnson Controls is currently marketing

⁵³ Binned simulation of conventional and task-ambient VAV systems utilizing economizing and considering COP effects for a typical office building in five U.S. cities: Albuquerque, Chicago, Miami, New York, and San Francisco.

their product actively, and other manufacturers have been marketing products in the U.S. since the early 1990s.

4.10.7 References

Arens, E.A., Benton, C., Brager, G.S., Bauman, F.S., and Heinemeier, K.E., 1991, "Task/Ambient Conditioning Systems in Open-Plan Offices: Assessment of a New Technology", California Energy Institute. September, Report No. UER-271-FR.

Bauman, F., Heinemeier, K., Zhang, H. Sharag-Eldin, A., Arens, E., Fisk, W., Faulkner, D., Pih, D., McNeel, P., and Sullivan, D., 1991, "Localized Thermal Distribution for Office Buildings: Final Report – Phase I", Center for Environmental Design Research, University of California at Berkeley, June.

Bauman, F. G. Brager, E. Arens, A. Baughman, H. Zhang, D. Faulkner, W. Fisk, D. Sullivan, and T. Borgers, 1992, "Localized Thermal Distribution for Office Buildings: Final Report – Phase II", Center for Environmental Design Research, University of California at Berkeley, December.

Bauman, F., Arens, E., Fountain, M., Huizenga, C., Miura, K., Xu, T., Akimoto, T., and Zhang, H., 1994, "Localized Thermal Distribution for Office Buildings: Final Report – Phase I", Center for Environmental Design Research, University of California at Berkeley, July.

Bauman, F., and Arens, E., 1996, "Task/Ambient Conditioning Systems: Engineering and Application Guidelines", Center for Environmental Design Research, University of California at Berkeley for the California Institute for Energy Efficiency, October, MOU No. 4902510.

CBPD, 1994, "DOE Building Studies", Center for Building Performance and Diagnostics, Carnegie Mellon University, October.

Fisk, W.J., 2000, "Health and Productivity Gains from Better Indoor Environments and their Relationship with Building Energy Efficiency", *Annual Review of Energy and the Environment*, vol. 25, pp. 537-566.

Huang, J., Hashem, A., Rainer, L., and Ritschard, R., 1990, "481 Prototypical Commercial Buildings for Twenty Urban Market Areas", Lawrence Berkley Laboratory for the Gas Research Institute, GRI Report 90/0326, June.

Schiller, G.E., Arens, E.A., Bauman, F.S., Benton, C.C., Fountain, M., and Doherty, T., 1998, "A Field Study of Thermal Environments and Confort in Office Buildings", *ASHRAE Transactions*, vol. 94, Part 2.

Lomonaco, C., and Miller, D., 1997, “Environmental Satisfaction, Personal Control and the Positive Correlation to Increased Productivity”, Johnson Controls, Inc. publication, PUBL-2911.

Wyon, D.P., 2000, “Enhancing Productivity While Reducing Energy Use in Buildings”, Paper Prepared for the E-Vision 200 Conference, 11-13 October, Washington, D.C.

4.11 Novel Cool Storage Concepts (Thermal Energy Storage [TES])

4.11.1 Summary

Novel cool storage devices store “cooling” generated off-peak (e.g., nighttime) in anticipation of high cooling loads in a phase change materials (PCMs) with transition temperature approximately equal to the chilled water generation temperature. By using the stored “cooling” to displace a significant portion of on-peak cooling loads, TES enables substantial reduction of installed chiller capacity and peak electricity demand. PCM-based systems save energy relative to conventional ice-based TES systems because the cooling cycle operates at a higher (~15°F) evaporator temperature. Relative to a conventional chiller, PCM-based TES saves energy due to the higher generation efficiency of marginal off-peak electricity generation, as well as off-peak lower off-peak condenser temperatures (particularly for air-cooled condensers). The economics of PCM-based TES depends greatly upon local utility rate structures, above all demand charges. In addition, the space consumed by TES systems represents may have a major impact on the effective system cost. Development of lower cost, compact TES systems for smaller (air-cooled) cooling systems would enable greater market penetration of this technology.

Table 4-30: Summary of Thermal Energy Storage (TES) Characteristics

Characteristic	Result	Comments
Technical Maturity	Current	Almost all TES installations are ice- or water-based
Systems Impacted by Technology	Chilled water systems	
Readily Retrofit into Existing Equipment/Buildings?	Depends	Cool storage tanks take up some space, which could pose a problem in space-constrained situations
Relevant Primary Energy Consumption (quads)	1.2 / 0.3	Potentially, all non-individual systems; at present, almost uniquely only chilled water systems
Technical Energy Savings Potential (quads)	0.2 / 0.03	Including air-cooled systems / only water-cooled systems. ~20% cooling energy savings for air-cooled systems, ~10% energy savings for water-cooled systems
Approximate Simple Payback Period	Varies greatly	Depends greatly upon the local electricity rate structure, particularly the demand charge and its structure (e.g., ratchet), as well as local cost of space for TES
Non-Energy Benefits	Load-leveling can significantly reduce the required chiller tonnage, potentially reducing system first cost; reduction of required storage volume relative to water TES systems	

Notable Developers/Manufacturers of Technology	Cristopia (PCM); Cryogel (prior PCM work, ice balls); Calmac (Roofberg [®] ice storage for rooftop units); several conventional (ice-based) system manufacturers.	
Peak Demand Reduction	Yes	Most TES systems have been sold (and utilities have provided incentives) by virtue of their ability to reduce peak electricity demand. By replacing all or a portion of chiller operation during peak demand periods with stored “cooling”, TES can achieve dramatic peak demand reductions.
Most Promising Applications	Buildings with high cooling loads, in regions with large diurnal temperature (especially wet bulb) swings, regions with very high electricity demand charges that ratchet to the entire year	
Technology “Next Steps”	Lower cost storage units for air-cooled condenser applications	

4.11.2 Background

Thermal energy storage (TES) systems store a sizeable quantity of “cool” thermal energy which is used to help meet the cooling load of a building. A typical system consists of a large vessel filled with water or brine that may contain multiple small containers (e.g., encapsulated bricks or balls) filled with a material (usually water) whose liquid-solid phase change temperature is somewhat lower than the building’s chilled water temperature (see Figure 4-18).



Figure 4-18: Thermal Energy Storage System Tanks (from Calmac Manufacturing Corp.)

In anticipation of periods requiring large cooling loads, i.e., at night, a chiller produces chilled water that flows to the vessel, causing the encapsulated material to solidify (change phase) and creating a low-temperature reservoir. In other systems, an ice harvester may produce ice. When the building requires elevated levels of cooling during the day, the cooling system passes the chilled water line through the TES tank, cooling the water and thus decreasing (i.e., leveling) the chiller load over the course of the day (see Figure 4-19⁵⁴).

⁵⁴ Note that for the case depicted in Figure 4-19, the net cool storage at the beginning of the day is assumed to equal approximately the net cool storage at the end of the day.

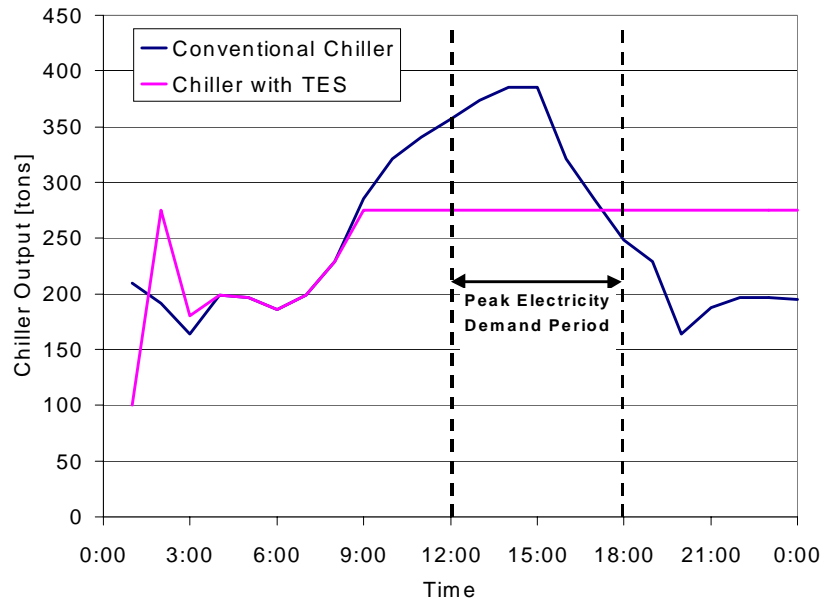

Figure 4-19: Illustrative Example of How TES Levels Chiller Output

Cler et al. (1997, p. 11, from Potter, 1994) estimates an installed base of 2,000-2,500 cold storage installations in the U.S. with an annual market in the \$31-\$34 million range; almost all of these are water- or ice-based systems⁵⁵. However, recent decreases in utility programs to support TES installation may have led to a decrease in current market size.

To date, only a very small fraction of TES systems have used a phase change material (PCM) besides water, typically hydrated salts with a phase change temperature of 47°F (ASHRAE, 1999). This novel cool storage approach saves energy in several ways relative to conventional chillers and more traditional ice-based cool storage. First, relative to ice-based systems, a phase change material with a temperature closer to the chilled water temperature (~47°F) instead of water (32°F) results in a smaller chiller lift, reducing the energy required to create cooling. Second, night operation of a chiller takes advantage of lower dry bulb (for air-cooled condensers) or lower wet-bulb (for water-cooled condensers) temperatures relative to daytime values, which also reduces the chiller lift. Third, on average, the baseload power plants operating in the middle of the night have a higher electricity generation efficiency (on a primary energy basis) than the plants brought on line to meet peak electricity demand during the cooling season, resulting in a primary energy savings from displacing daytime chiller operation with nighttime operation⁵⁶. Fourth, electricity transmission and distribution (T&D) losses typically are higher during peak

⁵⁵ Wildin (2001) reported that, based on an ASHRAE survey, 87% of TES systems use ice, 10% water, and 3% eutectic salt as the storage medium, with capacities ranging from 100 to 29,000 ton-hours (average of 3,000 to 4,000 ton-hours).

⁵⁶ For a specific potential installation, the value can vary substantially based on geographic region and the local utility.

demand periods than during the night, due to the increased power flow through the grid and the related increase in line resistance⁵⁷.

4.11.3 Performance

Summary: PCM- or liquid water-based TES systems can realize about 10% primary energy savings relative to a conventional water-cooled chiller, with improved electricity generation efficiency accounting for most of the energy savings. Relative to an air-cooled chiller, PCM- and liquid water-based TES systems can realize about 20% primary energy savings due to both improved electricity generation efficiency and lower nighttime condensing temperatures. For both scenarios, the condenser cooling approach is assumed to be the same as for the non-TES approach. In both cases, the specific primary energy savings for a given installation will depend greatly upon the difference between on-peak and off-peak marginal electricity generation heat rates. In most instances, ice-based TES systems actually consume more primary energy than a conventional chiller due to higher cycle lifts caused by lower evaporator temperatures needed to freeze the ice.

The energy consumption of a PCM-based TES system was compared to the operation of an ice-based TES system and a conventional chiller, both deployed to serve an office building in the Atlanta climate. Typical meteorological year data (NREL, 1995) were combined with building load data developed for ADL (1999) to develop the model for annual cooling loads. A load-leveling strategy was adopted for this system, i.e., identifying the minimum chiller size that could adequately meet the integrated cooling load during operating hours via 24-hour operation at a level approaching full capacity, and enabled down-sizing of the chiller from 500 tons (without TES) to 300 tons. Subsequently, the integrated cooling load during potential peak demand periods⁵⁸ was found to equal about 52% of the annual cooling load (see Table 4-31) and that a minimum of 40% of the peak period cooling demand could be met by cooling during the nighttime period. In practice, a substantially larger portion of the load could be shifted to off-peak periods, particularly on days that do not approach peak cooling loads. Overall, a relatively small number of hours account for a large portion of annual cooling loads.

Table 4-31: Thermal Energy Storage Model for a 100,000 ft² Office Building in Atlanta

Metric	Value	Comment
Peak Load Cooling Load [ton-hours]	230,000	Over a period of 918 "peak" hours
Annual Cooling Load [ton-hours]	440,000	
Conventional Chiller Capacity	500 tons	
TES System Chiller Capacity	300 tons	
Minimum % of Annual Cooling Load Shifted to Nighttime	21%	From the noon-6pm period to 11pm to 5am; Based on daily load leveling
Wet Bulb Temperature Difference	1.9°C	From the noon-6pm period to 11pm to 5am
Dry Bulb Temperature Difference	6.5°C	From the noon-6pm period to 11pm to 5am

Table 4-32 shows that, on average, the wet bulb temperature in Atlanta does not vary nearly as much from day to nighttime as does the dry bulb temperature, indicating that cool storage

⁵⁷ As the lines heat up, their resistance increases, further increasing line losses.

⁵⁸ Defined here as from noon to 6pm, from May through September

energy savings potential for air-cooled condensers is significantly larger than for water-cooled condensers. A calculation was performed to get an idea of the vapor compression cycle efficiency gains from lower nighttime cooling temperatures relative to the daytime, using R-22 as the refrigerant and using average temperatures from each period (see Table 4-32).

Table 4-32: Temperature Impact of Off-Peak TES Cooling Versus On-Peak Cooling

Scenario	Water-Cooled Condenser ⁵⁹		Air-Cooled Condenser ⁶⁰	
	ΔT	Efficiency Gain	ΔT	Efficiency Gain
Conventional Chiller, 12pm-6pm	50°F	Baseline	61°F	Baseline
PCM-Based Chiller, 11pm-5am	47°F	8%	49°F	27%
Ice-based TES, 11pm-5am	62°F	-20%	64°F	-8%

Nighttime cooling consumes less energy than daytime cooling, particularly for an air-cooled condenser. Moreover, the PCM-based TES consumes about 30% less energy than the ice-based TES, due to the decreased temperature lift of the PCM-based cycle (i.e., because water changes phase at 32°F versus 47°F for the PCM). On the other hand, TES does experience between 1-5% thermal loss from tanks per day (Cler et al., 1997).

As noted earlier, TES also can reduce energy consumption by shifting electricity consumption to off-peak period when the *marginal* electricity produced is generated with a higher efficiency⁶¹ and T&D losses are reduced. Unfortunately, national average data for on- and off-peak electricity generation efficiency and T&D losses could not be found. Data were found for the state of California (from CEC, 1996) that compare heat rates and T&D losses for two major California utilities (see Table 4-33); although these values are not necessarily representative of values for the entire country, they do provide a general magnitude for the savings potential.

Table 4-33: Comparison of On-Peak and Off-Peak Heat Rate and T&D Losses

Value	Southern California Edison	Pacific Gas & Electric	Average Value
Peak Periods	12pm-6pm, June through September	12pm-6pm, May through October	
Off-Peak T&D Losses, as % of On-Peak	95.3%	N/A	95.3%
Off-Peak Heat Rate of Marginal Electricity Production, as % of On-Peak	69.3%	92.3%	81%

Overall, the California results suggest that substituting off-peak electricity consumption for on-peak consumption reduces energy consumption by more than 20%.

⁵⁹ Assumes 47°F chilled water temperature, 7°F refrigerant-evaporator ΔT , 20°F refrigerant-condenser ΔT , 70°F/67°F daytime/nighttime wet bulb temperature.

⁶⁰ Assumes 47°F chilled water temperature, 7°F refrigerant-evaporator ΔT , 20°F refrigerant-condenser ΔT , 81°F/69°F daytime/nighttime wet bulb temperature.

⁶¹ In general, coal-fired, nuclear, and (for some regions) hydro are base-load electricity plants, whereas as combustion turbine and gas combined cycle plants tend to satisfy marginal "on-peak" demand.

Combining the results from the prior tables reveals that the net energy impact of TES depends upon the actual amount of energy storage shifted to off-peak periods (see Figure 4-20).

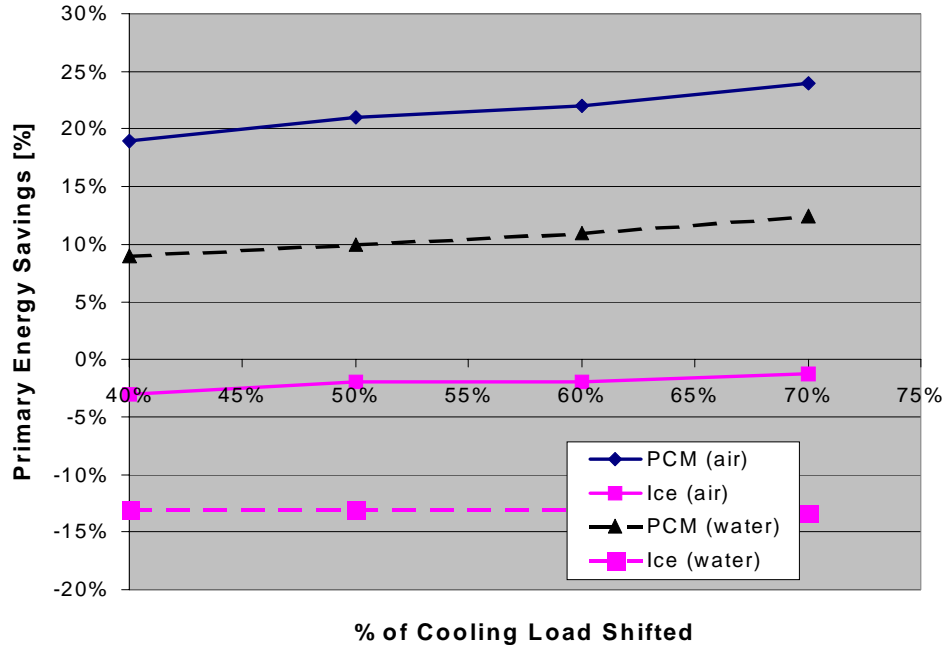

Figure 4-20: Simple Model of TES Impact on Primary Energy Consumption

As noted earlier, 40% represents a lower bound on the percentage of load that could be shifted from peak periods. In all cases, the simple model shows that PCM- or water-based TES realizes energy savings on the order of 10% for water-cooled systems, a value that corresponds closely with the chilled water storage savings for retrofit applications cited in CEC (1996). Moreover, air-cooled systems would achieve ~20% energy savings relative to conventional cooling. In all cases, the ice-based cooling appears to consume more energy, due to the lower COP of the vapor compression cycle.

4.11.4 Cost

Summary: PCM-based TES costs ~\$100 to \$150/ton-hour and can displace a significant portion of chiller capacity. Not taking into account the cost of the space required for the TES, liquid water-based systems can often have lower first costs than conventional systems, while PCM-based have favorable economics in areas with high electricity demand charges without major space constraints. Ice-based TES systems only may have favorable payback in areas with very high electricity demand charges.

Cler et al. (1997) estimate the following costs for TES (see Table 4-34).

Table 4-34: Thermal Energy Storage Cost Estimates (from Cler et al., 1997⁶²)

Storage Medium	Chiller: \$/Ton	Installed Tank Cost, \$/Ton-hr
H ₂ O	\$200-300	\$30-100
Ice Slurry	\$200-500	\$20-30
Ice Harvester ⁶³	\$1,100-1,500	\$20-30
Encapsulated Ice	\$200-500	\$50-70
PCM	\$200-300	\$100-150

Ott (2000) reported similar costs for PCM-based storage systems, primarily due to the cost of PCMs, the need to use special materials to handle PCMs, and larger tank volumes required (about double that of encapsulated ice storage needed to accommodate water plus encapsulated PCMs). In residential/small commercial installations, Ott (2000) estimated the approximate TES prices in the range shown in Table 4-35; in practice, prices are not truly a linear function of capacity.

Table 4-35: Encapsulated Water and PCM TES Costs (from Ott, 2000; includes 1.55 mark-up)

System Type	Material Costs [\$/Ton-Hour]	Tank Costs [\$/ton-hour]	Total Tank + Material Costs [\$/ton-hour]
ICE (H ₂ O) – Encapsulated	\$30	\$15 - \$23	\$45 - \$53
PCM – Encapsulated	\$95	\$45 - \$70	\$140 - \$165

For the 100,000 ft² office considered in the “performance” section, building load estimates showed that a chilled water system outfitted with a 400-ton chiller in Atlanta could be down-sized to a 250- or 300-ton chiller, with 900 or 500 ton-hours of TES, respectively. Using the cost data presented above, a PCM-based TES system would have a ~40% or ~80% price premium, while the chilled water storage has a ~15% lower first cost than the conventional chiller option. Importantly, none of these calculations take into account the cost of the space used for the TES system, a crucial consideration in numerous applications.

Simple payback periods for the PCM-based TES exhibit great sensitivity to the local electricity rate structure, notably the demand charge. For all rate structures without a demand charge, PCM TES has a simple payback period on the order of decades. For all other cases, the economics depend greatly upon demand charges and whether they are applied on a month-by-month basis or a peak rate is applied to the entire year (see Table 4-36).

⁶² Excepting the PCM storage cost, all values coincide with the cost estimates of Dorgan and Elleson (1993).

⁶³ Leaders (2000) cited ice storage systems costs of \$60-\$80/ton-hour of storage, \$900 per ton of ice production capacity.

Table 4-36: Impact of Rate Structure on PCM-Based TES Economics

Rate Structure	PCM-Based TES Simple Payback Period [years]
\$0.05/kWh	68
\$0.10/kWh	57
\$0.20/kWh	29
\$0.055/kWh + \$5/kW [12-month ratchet]	7.4
\$0.055/kWh + \$10/kW [12-month ratchet]	3.8
\$0.055/kWh + \$15/kW [12-month ratchet]	2.6
Note: System has water-cooled 300-ton chiller versus 400 ton conventional chiller and 500 ton-hours of TES; demand charge based on chiller efficiency of 0.8kW/ton	

4.11.5 Perceived Barriers to Market Adoption of Technology

TES has encountered several problems in the marketplace. Often, particularly for ice-based but also for PCM-based systems, a system with TES has a higher first cost than a conventional chiller, even without taking into account the cost of the land needed to accommodate the TES system. In the past, utilities have attempted to overcome this issue by offering financial incentives to companies that install TES systems (e.g., Nye, 2001). The size of TES tanks has posed problems in many space-constrained applications (e.g., downtown office buildings). PCM-based systems have raised potential health/safety concerns, due to handling concerns and the possibility of leaks of the material out of their encapsulation and/or tank. Finally, over time PCMs can breakdown and stratify due to stagnation within the balls, which reduces their thermal capacity and performance.

4.11.6 Technology Development “Next Steps”

Two developments could improve the outlook for TES. First, if possible, the identification of inexpensive, reliable, non-toxic PCM materials with appropriate transition temperatures and high heat capacities would improve the economic attractiveness of PCM-based TES. Second, the development of lower-cost small scale cool storage, particularly PCM-based systems for use with air-cooled equipment, would extend the relevance of TES to a larger portion of the commercial HVAC market and into applications with the potential for shorter simple payback periods due to higher avoided equipment costs, greater energy and demand charge savings.

4.11.7 References

ASHRAE, 1999, **ASHRAE Handbook, 1999: HVAC Applications**, ASHRAE Press: Atlanta, GA.

California Energy Commission, 1996, “Source Energy and Environmental Impacts of Thermal Energy Storage”, Prepared by Tabors, Caramanis & Associates for the California Energy Commission, February.

Cler, G. et al., 1997, **Commercial Space Cooling and Air Handling: Technology Atlas**. E Source, Inc.

Dorgan, C.E. and Elleson, J.S., 1993, **Design Guide for Cool Thermal Storage**, ASHRAE Press: Atlanta, GA.

Leaders, D., 2000, Personal Communication, Paul Mueller Company.

NREL, 1995, “Typical Meteorological Years – Derived from the 1961-1990 National Solar Radiation Data Base”, National Renewable Energy Laboratory.

Nye, H., 2001, “L.A. DWP Energy-Efficiency Programs,” *ACHRNews*, 24 December, p. 21.

Ott, V., 2000, Personal Communication, Cryogel.

Wildin, M.W., 2001, “Thermal Energy Storage – A Primer”, *Energy User News*, August, pp. 38-40.

4.12 Radiant Ceiling Cooling / Chilled Beam

4.12.1 Summary

Buildings with radiant ceiling cooling systems, also known as “chilled beam” systems, cool the room via natural convection and radiative heat transfer. As noted by Mumma (2001b), current systems almost always require dedicated outdoor air systems (DOAS) and tight building envelopes to manage humidity. Energy saving are realized by significant reductions in air moving power (only the outdoor make-up air is distributed to the building) and the higher evaporator temperature of the chiller supplying cool water to the chilled ceiling panels.

Table 4-37: Summary of Radiant Ceiling Cooling Characteristics

Characteristic	Result	Comments
Technical Maturity	Current	Much more common in Europe than in the U.S.
Systems Impacted by Technology	All HVAC systems	
Readily Retrofit into Existing Equipment/Buildings?	No	Requires installation of large ceiling panels and piping throughout building.
Relevant Primary Energy Consumption (quads)	3.4 Quads	All non-individual cooling and ventilation energy, heating energy tied to OA
Technical Energy Savings Potential (quads)	0.6 Quads ⁶⁴	<ul style="list-style-type: none"> • 17% cooling energy reduction • 10% heating energy reduction (all from DOAS) • 25% ventilation energy reduction
Approximate Simple Payback Period	Potentially immediate	In new construction or major renovation
Non-Energy Benefits	Improved occupant comfort, low noise, low maintenance	Radiant heating/cooling generally considered more comfortable than forced-air methods. Low maintenance (assuming humidity issue properly managed). Less noise from air distribution. According to Stetiu (1997), radiant cooling reduces ventilation, which reduces space needed for ducts by up to 75%. Zoning readily implemented.
Notable Developers/Manufacturers of Technology	Frenger (Germany). Trox (Germany). Dadanco (Australia; Active Chilled Beams; uses smaller fans to distribute primary air through unit, in combination with secondary, room air)	
Peak Demand Reduction	Yes	Decreases the peak ventilation load required to deliver peak cooling. Stetiu (1997) found 27% demand reduction on average (throughout U.S.).
Most Promising Applications	Tight buildings with high sensible cooling loads, located in low-humidity cooling climates (e.g., hospitals due to one-pass ventilation requirement). Not buildings with appreciable internal moisture loads (e.g., health/fitness clubs, pools).	
Technology “Next Steps”	HVAC system designer/installer education with approach; integration into commonly-used HVAC design tools; demonstration of operational benefits. Cost comparison with VAV system using an enthalpy wheel and dedicated outdoor air systems. Energy savings of chilled beam versus VAV.	

4.12.2 Background

Buildings with radiant ceiling cooling systems, also known as “chilled beam” systems, incorporate pipes in the ceilings of the buildings through which cold water flows. The pipes lie close to the ceiling surfaces or in panels and cool the room via natural convection and radiative heat transfer (see Figure 4-21). The technology has existed for more than 50 years; however, condensation caused moisture to accumulate on the cooled surfaces, causing ceiling materials (e.g., plaster) to fail and creating conditions favorable to biological growth. As noted by Mumma (2001b), current systems almost always require dedicated outdoor air systems (DOAS; see write-up in Section 4.2) and very tight building envelopes to manage humidity.

⁶⁴ Relative to a DOAS, Radiant Ceiling Cooling has an additional technical energy savings potential on the order of ~0.2 quads.

In typical commercial buildings, the strategy for avoiding condensation on radiant panels is straightforward. A separate system maintains the dewpoint in the space below the temperature of the radiant panels. In most instances, the predominant source of peak humidity load is the humidity contained in ventilation make-up air. Therefore, one option for handling the humidity loads separately from the chilled ceiling is to dehumidify the make-up air, with enough “extra” humidity removed to cover internal moisture generation, prior to introduction to the space. Mumma (2001c) reports that with good base dewpoint control, the chilled panels are quite forgiving (with respect to condensation formation) during upsets, such as unanticipated increases in occupancy or other temporary increases in local moisture loads and dewpoint.

A radiant ceiling cooling system directly delivers sensible cooling to spaces, de-coupling maximum air delivery from the cooling load and reducing ventilation fan energy consumption. Typically, the radiant and natural convection cooling capacity of chilled ceiling panels are comparable, with the combined radiant and natural convection cooling capacity being sufficient to meet peak sensible loads with approximately 50% of the ceiling area covered by cooled panels (for a cooling load on the order of 16 Btu/hr-ft²). With sensible cooling separated from ventilation, ventilation can be provided as needed to satisfy ventilation requirements (on a prescribed cfm/ft² basis, or as determined by CO₂ sensors). As discussed above, radiant panels necessitate the use of a dedicated system for dehumidifying the outdoor air, an approach that, although not unique to radiant panel systems, also reduces ventilation energy consumption relative to a typical VAV system (Mumma, 2001a). In addition, because radiant panels must operate at higher temperatures to avoid condensation, they decrease the lift of the vapor compression cycle delivering the cooling, improving the cycle COP. Finally, radiation heat transfer delivers “cool” directly to the occupants’ bodies, which may allow slightly higher building air temperatures, decreasing building cooling loads.

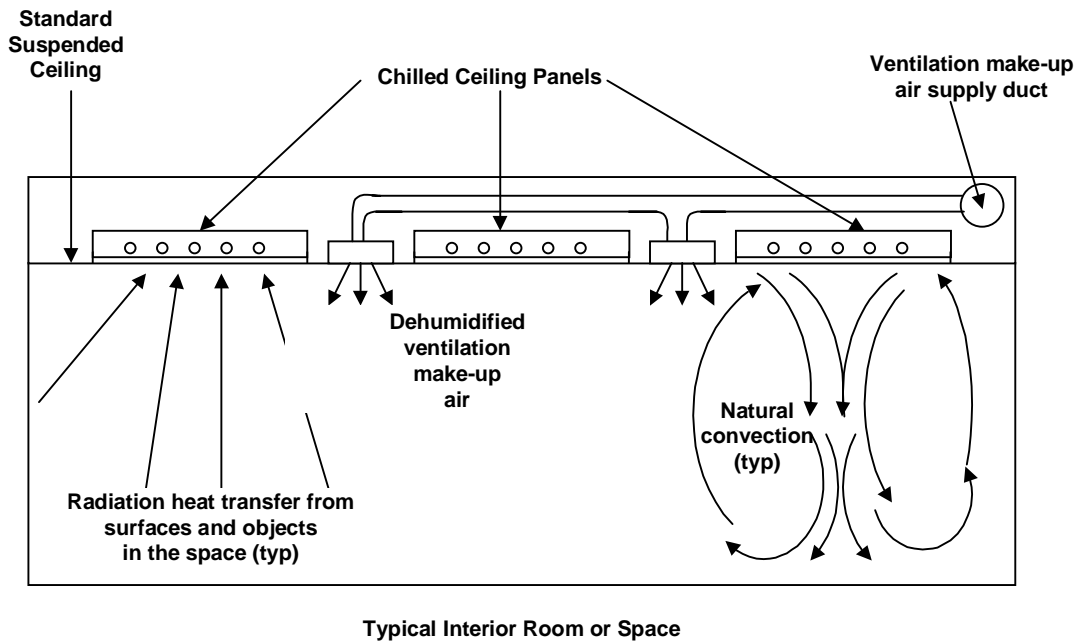

Figure 4-21: Principles of Radiant Ceiling Panel Cooling

It should be noted that DOAS also could be used in parallel with a sensible-only VAV system (instead of a chilled ceiling system), with similar advantages. A detailed comparison of the energy savings and installation costs of DOAS in parallel with each type of sensible load handling system would be useful.

4.12.3 Performance

Summary: Cooling panels/chilled beams (in combination with a DOAS) can reduce cooling and ventilation energy consumption by 25-30% relative to a VAV system.

For passive ceiling panels, the cooling capacity typically is split evenly between radiation and natural convection heat transfer. For example, Frenger ceiling panel units have a capacity split of ~40%/60% radiant/convection, at a density of up to 150W/m² (50 Btu/ft²) of cooling⁶⁵ (Frenger, 2001). Active chilled beam units (e.g., Dedanco active chilled beam units, using recirculated room air flow induced by the ventilation make-up air supply) can supply between 25 and 250 W/m² and achieve ~17% fan power reduction relative to conventional VAV. Each unit can be controlled independently, leading to simple zoning (Dedanco, 2001).

One of the basic energy savings mechanisms is the ability to operate with higher chilled water temperature, allowing the chiller evaporator temperature to be correspondingly higher. According to Springer (2001), chilled ceiling panels typically use 50°F water rather than 40-45°F, while Feustel (2001) noted that an installation in Germany uses the following

⁶⁵ Stetiu (1997) reported a similar value of up to 140W/m².

temperatures: 95°F supply (88°F return) to maintain space at 68°F during the heating season; and 61°F supply, 66°F return, 80°F space temperature for cooling.

As noted earlier, radiant ceiling cooling systems in most climates require installation with a system to manage OA humidity, e.g., a DOAS. Together, the DOAS with radiant ceiling cooling saves energy by reducing air moving power, reducing total ventilation air flow and by handling sensible cooling loads more efficiently. Air moving power is reduced because the only air moved is that required for ventilation (only 25% to 30% of the air flow rate required for peak cooling loads in an all-air system). When the DOAS is designed with ducts matched to this reduced, but constant, flow requirement, blower power is not reduced at periods of low load, as is the case with VAV⁶⁶. Importantly, however, a DOAS can meet ASHRAE 62 ventilation requirements with less ventilation air flow due to the inherent precision of the DOAS in delivering required ventilation flows in the aggregate and in the individual zones in the building.

TIAX developed a simple analysis to compare the energy consumption of a conventional VAV system with a radiant ceiling cooling + DOAS system. Using building load data and binned weather data to compare the air moving performance of the two systems for a small office building in a Middle Atlantic states climate, the radiant + DOAS system realized annual blower power savings on the order of 25%, with larger savings in warmer climates (see Table 4-38). In space cooling mode, energy savings include the benefit of higher chilled water temperature to the radiant ceiling panels for the sensible part of the load, reduced air moving power dissipated within the conditioned space, and reduced ventilation flows to be cooled. In space heating mode, energy is saved as a result of the reduced ventilation air flow allowed by the inherent precision of the DOAS in delivering required ventilation flows in the aggregate and in the individual zones in the building. Simulations show that typically 50 to 60% of the space heating load is due to heating outside air. The DOAS allows outside air to be reduced by approximately 20%, resulting in space heating energy savings on the order of 10%.

Table 4-38: Energy Savings by Radiant Cooling Systems with DOAS Versus Conventional VAV

Category	Percent Energy Saved
Space Heating	8-12%
Space Cooling ⁶⁷	15-20%
Ventilation (air moving) power	20-30%

These results agree reasonably well with the findings from building simulations by Stetiu⁶⁸ (1997), who estimated 17% savings in cold, moist areas to 42% in warm, dry areas, with an average of 30%. Similarly, simulations for an office building in Philadelphia found ~23% decrease in annual HVAC operating expenses (Mumma, 2001b).

⁶⁶ Analysis by TIAX compared air moving energy savings for same sized ducts (baseline VAV vs. DOAS) and for ducts that were downsized in proportion to the reduced design air flow rate of the DOAS system. When the duct cross section remained constant, annual air moving power reductions in excess of 80% occur. When the DOAS duct cross section was reduced to reflect the required OA, air moving energy saving range from nil (moderate climate) to 30% (warm climate). This result indicates that the optimum duct cross section for a DOAS combined with radiant panels is larger than a simple scale down of design air flow rates – reflecting the constant flow use of these ducts by the DOAS.

⁶⁷ Chilled water temperatures: Conventional VAV = 44°F; DOAS = 44°F; Radiant Ceiling Panel = 54°F.

⁶⁸ Using RADCOOL with DOE2.1 inputs

In general, the requirement of a DOAS in most radiant cooling applications generally precludes economizer operation at levels above and beyond those needed to satisfy OA requirements, as the DOAS would most likely not include additional ventilation capacity.

4.12.4 Cost

Summary: In new construction, the installed costs of cooling panel/chilled beam systems plus an appropriately sized DOAS system with enthalpy recovery are similar to conventional VAV systems. However, this depends upon the incorporation of other system components, i.e., if the system requires separate radiant heating systems to meet heating needs, the cooling panel/chilled beam system costs substantially more than an all-air system. A number of sources, indicated below have made similar statements about comparative costs.

Mumma (2001b) posits that a cooling panel system, when used in combination with a dedicated outdoor air system (DOAS) outfitted with sensible and enthalpy transfer devices, costs less to construct than a VAV-based system. It is not completely clear if cooling panels would cost less than a sensible-only VAV system combined with a DOAS (as advocated by (Coad, 1999) (and enthalpy and sensible energy transfer); a price quote provided by a chilled beam manufacturer found that the chilled beam system cost 2% more than a VAV system, with large decreases in costs of ducts and fan equipment (Petrovic, 2001). Similarly, Springer (2001) stated that costs are competitive with VAV, due in large part to lower ventilation costs. One case study by Energy Design Resources (2001) showed a 40-55% reduction in space requirements for mechanical equipment and ductwork due to less ducting. In new construction, this can be translated in lower construction costs and more leasable floorspace. A Dedanco system only costs 2% more than a VAV system, with large decreases in costs of ducts and fan equipment (Dedanco, 2001b).

4.12.5 Perceived Barriers to Market Adoption of Technology

Overall, HVAC system designers and contractors are unfamiliar with the panel cooling approach and often have the perception that it has a higher first cost than other systems. In addition, installation of a radiant ceiling has architectural implications, necessitating early communication on a project between architects and HVAC system designers. Historically, radiant cooling also suffers from past problems encountered involving condensation (and resulting moisture) problems due to higher infiltration levels in older buildings and untreated outdoor air. As noted by Mumma (2001b), “panel cooling cannot be considered unless a parallel system is in place to de-couple the space sensible and latent loads.”

4.12.6 Technology “Next Steps”

- HVAC system designer/installer education with approach;
- Integration into commonly-used HVAC design tools⁶⁹; demonstration of operational benefits.
- Cost and energy consumption comparison with VAV system using an enthalpy wheel and dedicated outdoor air systems.

⁶⁹ Presently, the DOE program EnergyPlus can include DOAS (more information available at: http://www.eren.doe.gov/buildings/energy_tools/energyplus/).

4.12.7 References

Coad, W.J., 1999, Conditioning Ventilation Air for Improved Performance and Air quality,” *Heating Piping and Air Conditioning*, September, pp. 49-56.

Dedanco, 2001, Active Chilled Beam Documentation/FAQ. Available at: www.dadanco.com.au .

Energy Design Resources, 2001, “Design Brief: Radiant Cooling.” Final Draft, prepared by Financial Times Energy, Inc.

Feustel, H., 2001, IES International Energy Studies, Inc. “Hydronic Radiant Cooling”.

Mumma, S.A., 2001a, “Fresh Thinking: Dedicated Outdoor Air Systems”, *Engineered Systems*, May, pp. 54-60. Available at: <http://www.doas.psu.edu/papers.html> .

Mumma, S.A., 2001b, “Ceiling Panel Cooling Systems”, *ASHRAE Journal*, November, pp. 28-32. Available at: <http://www.doas.psu.edu/papers.html> .

Mumma, S.A., 2001c, “Dedicated Outdoor Air in Parallel with Chilled Ceiling System”, *Engineered Systems*, November, pp. 56–66. Available at: <http://www.doas.psu.edu/papers.html> .

Petrovic, V.M., 2001, Personal Communication, Dedanco.

Springer, D., 2001, Personal Communication, Davis Energy Group.

Stetiu, C., 1997, “Radiant Cooling in US Office Buildings: Towards Eliminating the Perception of Climate-Imposed Barriers”, Doctoral Dissertation, Energy and Resources Group, University of California at Berkeley, May. Available at: <http://epb1.lbl.gov/EPB/thermal/dissertation.html> .

4.12.8 Appendix

Building simulations (by Stetiu (1997), using RADCOOL with DOE2.1 inputs) showed that radiant cooling saves 17% in cold, moist areas to 42% in warm, dry areas, with an average of 30%; loads of up to 140W/m² (45 Btu/ft²) managed by radiant cooling. A typical energy breakdown (for the warm-dry climate case) is given in Table 4-39. Note that the duct cross section was not reduced from the VAV case to the radiant panel case. If the duct cross-section was reduced in proportion to the reduction in design air flow rates, the energy savings for air moving power would be less than indicated. It was assumed that half of the heat from the lighting is carried out of the space in the ventilation exhaust air. Also note that the “other loads” (essentially the sensible interior loads) are the same for both cases, so the possibility of increasing the chiller evaporator temperature for radiant panels is not accounted for in this analysis.

Table 4-39: Peak HVAC Energy Consumption Comparison, VAV Versus Radiant Cooling (from Stetiu, 1997)

Item	% Power in VAV	% Power in Radiant Cooling
Fan and motor	37.5%	1.5%
Load from lights	18.8%	9.4%
Air transport load	9.3%	1.9%
Other loads	34.4%	34.4%
Pumps	---	1.5%
Total	100%	57.7%

4.13 Smaller Centrifugal Compressors

4.13.1 Summary

Centrifugal compressors presently are used in chillers with tonnages in excess of 80 tons (ASHRAE, 1998). In fact, the trend has been for screw compressor based chillers to be used in most applications below 300 to 400 tons, with centrifugal compressors used in larger capacities. This option would combine high speed motor technology with centrifugal compressor technology to extend the optimum capacity range lower, providing centrifugal compressors for chillers and unitary air conditioners in smaller sizes, i.e., 25 to 80 tons, currently served primarily by scroll and reciprocating compressors. The potential advantages include increased efficiency, efficient capacity modulation, reduced size and weight, and reduced noise.

Table 4-40: Summary of Smaller Centrifugal Compressor Characteristics

Characteristic	Result	Comments
Technical Maturity	Advanced	Approximate time to commercialization: 3-4 years from the time it is pursued seriously
Systems Impacted by Technology	Refrigerant compressors 20-80 tons capacity	Primary applications – large unitary air conditioners and reciprocating/scroll chillers
Readily Retrofit into Existing Equipment/Buildings?	No	Typically compressors are replaced (with identical replacement compressor) in the field, but a different type compressor would not be installed in the field.
Relevant Primary Energy Consumption (quads)	0.9 quad	Energy consumption of commercial unitary plus reciprocating/scroll chillers
Technical Energy Savings Potential (quads)	0.15 quad	~20% seasonal efficiency improvement, 16% annual energy reduction
Approximate Simple Payback Period	0 to 2 years	Cost potentially comparable to semi-hermetic reciprocating or scroll, once commercialized. Required start-up investment inhibits commercialization at present.
Non-Energy Benefits	Reduced size, weight, and noise levels. Improved occupant comfort from reduced cycling of heating and cooling systems to decrease temperature swings.	
Notable Developers/Manufacturers of Technology	UTC/Carrier	Major ATP program in the late 90's
Peak Demand Reduction	Yes	Potential for increased peak load efficiency of ~10%, relative to state-of-the-art scroll and semi-hermetic reciprocating compressors.
Most Promising Applications	Chillers and unitary air conditioners between 20 and 100 tons	
Technology "Next Steps"	Verify the full load and part load performance and cost (particularly current costs and trends for high speed motors and drives; further R&D and work to commercialize product	

4.13.2 Background

Centrifugal compressors presently are used in chillers with tonnages in excess of 80 tons (ASHRAE, 1998). In fact, the trend has been for screw compressor based chillers to be used in most applications below 300 to 400 tons, with centrifugal compressors used in larger capacities. This option would combine high speed motor technology with centrifugal compressor technology to extend the optimum capacity range lower, providing centrifugal compressors for chillers and unitary air conditioners in smaller sizes, i.e., 25 to 80 tons, currently served primarily by scroll and reciprocating compressors. The potential advantages include increased efficiency, efficient capacity modulation, reduced size and weight, and reduced noise.

The extension of well known centrifugal refrigerant compressor technology down to this capacity range is enabled by the use of electronically driven high speed (on the order of 50,000 RPM) motors, which run at the impeller speed (directly driving the impeller, without speed increase gearing). United Technologies Research Center/Carrier worked on a NIST ATP project for four years to develop a small, high-speed centrifugal compressor for commercial HVAC systems. Figure 4-22 (from Brondum et al., 1998) illustrates the design approach for a 25-ton prototype compressor designed to be capable of operating across the range of conditions normally encountered by unitary air conditioners. To obtain the necessary lift (from 45°F evaporating temperature to condensing temperatures approaching 150°F at high outdoor ambient temperatures), a two-stage design was selected. An additional advantage of the two-stage design is that a “refrigerant economizer” cycle can be used, increasing the COP by 5-7%. In the refrigerant economizer cycle, shown in Figure 4-23, the liquid refrigerant from the condenser is expanded in two steps, first to the interstage pressure between the two compressor stages, with the vapor that is flashed directed to the inlet of the second compressor stage, saving compression power. The remaining liquid is then expanded to evaporator pressure, with less vapor being flashed.

The potential of the high speed centrifugal compressor for reduced energy consumption is due to three factors:

- The full load efficiency of the compressor could be higher than what has been achieved with reciprocating, scroll, or screw compressors in this capacity range. The efficiency levels measured at 45/130 (standard compressor rating conditions – aerodynamic 84%, motor 94%, drive 97%, and allowing 2% for bearing losses equates to a standard conditions compressor EER of 12.4 Btu/W-hr, compared to 11.5 for the best scroll and semi-hermetic reciprocating compressors.
- The variable speed operation of the motor enables close matching of capacity to part-load demands, reducing unnecessary cycling losses, potentially increasing seasonal efficiency (by 20% compared to a single speed, single compressor, by 5% compared to a multiple compressor system).
- The aforementioned refrigerant economizer cycle increases the COP by 5-7%.

The combined effect of these factors is approximately 15% efficiency improvement at full load, plus the benefit to seasonal efficiency or IPLV provided by efficient capacity modulation.

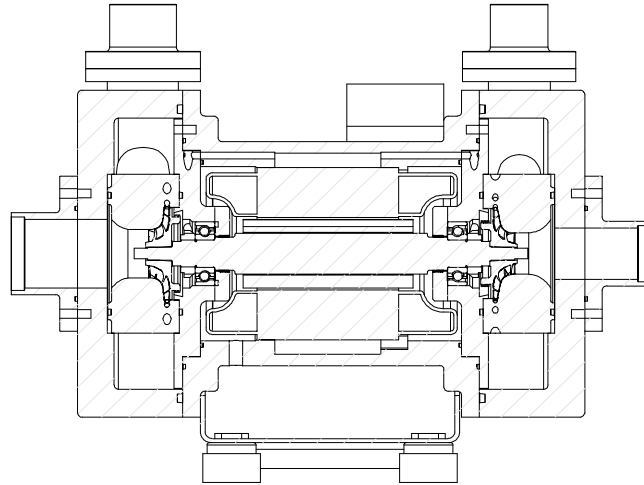

Figure 4-22: Two-Stage, Back-to-Back Configuration, Centrifugal Compressor Cross-Section (from Brondum et al., 1998)

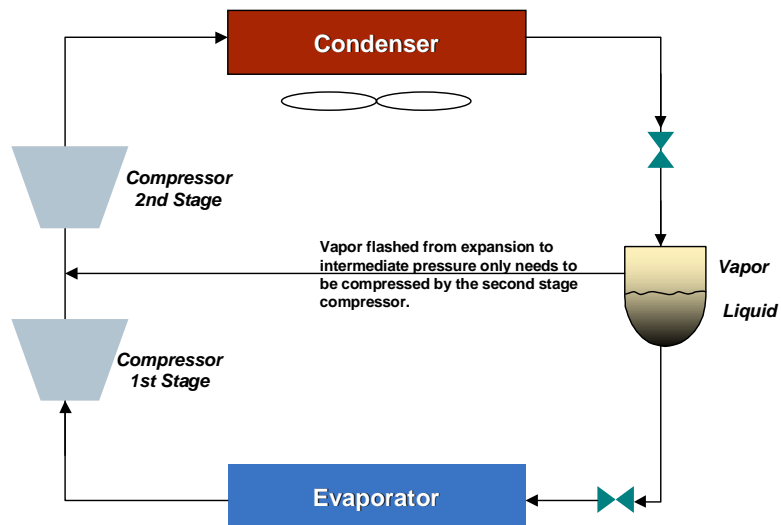

Figure 4-23: Refrigerant Economizer Cycle

United Technologies Research Center/Carrier worked on a NIST ATP for four years to develop a small, high-speed centrifugal compressor for commercial HVAC systems, with a 15 to 20% efficiency gain (compared to state-of-the-art single speed scroll, including both motor/compressor efficiency gain and the benefit of a refrigerant economizer cycle) at design point [Brondum et al., 1998]. Analytical assessments of systems showed that the

devices should attain the efficiency targets. Ultimately, Biancardi (2001) says that the prototypes met their design goals (10-20% design point efficiency gains).

4.13.3 Cost

In volume, projections show that centrifugal chillers can have approximately the same cost as reciprocating chillers. According to Biancardi (2001), the target was same cost as a reciprocating machine and they projected that, at 25,000 units/year, it could be met. The high-speed motor and inverter combined to account for 75% of the total system costs, signaling a major opportunity for further cost reductions as these fast-moving technologies come down further in cost.

4.13.4 Perceived Barriers to Market Adoption of Technology

Carrier decided against commercialization of technology for three reasons, which provide insight into the barriers facing small centrifugal compressor technology. First, on the low capacity end, Carrier had invested much in getting scroll compressors to work and did not want to go through (potentially) another similarly painful effort. Secondly, on the higher capacity end, reciprocating compressor products had no further development costs to amortize, so Carrier did not want to cannibalize their own product while incurring infrastructure costs needed to produce, sell and support a new product. Lastly, the overall market of 25,000 units seemed not large enough to justify displacing existing products.

4.13.5 Technology “Next Steps”

A primary next step would be to verify the full load and part load performance and cost, particularly current costs and trends for high speed motors and drives. If the high speed compressor still appears to be an attractive alternative (with respect to both energy saving and potential cost effectiveness), further R&D and commercialization work need to be completed by a compressor manufacturer to bring the product to market. In general, the product would tend to be a better fit for a company with limited market share in the target size range, as it would represent a growth opportunity without cannibalizing an existing product. Similarly, a company with high-speed motor/drive expertise would tend to have developmental and cost advantages. Finally, product categories/niches where the low noise and compact size of high speed centrifugal provides significant benefits should be clearly identified, as an impetus to begin commercialization.

4.14 References

ASHRAE, 1998, **1998 ASHRAE Handbook: Refrigeration**, ASHRAE Press: Atlanta, Georgia.

Biancardi, F., 2001, Personal Communication, Independent Consultant to United Technologies.

Brondum, D.C., Materne, J.E., Biancardi, F.R., Pandey, D. R., 1998, “High-Speed, Direct-Drive Centrifugal Compressors for Commercial HVAC Systems”, *Proceedings of the 1998 International Compressor Engineering Conference*, Purdue University, July 14-17.

4.15 System/Component Diagnostics

4.15.1 Summary

System diagnostics can be used to automatically identify failures in operation of HVAC equipment and systems. If such systems can identify inefficient system performance and alert building operators, the systems can be fixed sooner, thus reducing the time of operating in failure modes and thus saving energy. Although the approaches to implementing diagnostics vary widely, much fundamental work in this area has been done and many forms of diagnostics have been implemented. Further implementation of more sophisticated approaches and implementation for a wider range of equipment has the potential for significant energy savings. Nonetheless, developing market-acceptable approaches that successfully save energy will be a challenge for the companies attempting to commercialize this technology.

Table 4-41: Summary of System/Component Diagnostics Characteristics

Characteristic	Result	Comments
Technical Maturity	New	Significant R&D work has been done, diagnostic functionality is often built in to electronic controls, but the level of the diagnostic capabilities and the penetration of electronic control varies widely by equipment type.
Systems Impacted by Technology	All HVAC Systems	
Readily Retrofit into Existing Equipment/Buildings?	Yes	Stand-alone diagnostic systems are available but more expensive for new equipment.
Relevant Primary Energy Consumption (quads)	4.5	All HVAC energy consumption
Technical Energy Savings Potential (quads)	0.45	Based on very rough 10% energy savings estimate for all HVAC energy
Approximate Simple Payback Period	0.5 to 3 Years	Varies widely depending on implementation scenario
Non-Energy Benefits	<ul style="list-style-type: none"> • Prevention of equipment failure • Schedule maintenance when it is more convenient • Reduce building occupant discomfort 	Non-energy benefits are associated with the ability to avoid unexpected and potentially catastrophic equipment failures.
Notable Developers/Manufacturers of Technology	Major Control Vendors (Honeywell, Siemens, etc.), niche market service vendors, a number of research organizations and universities (NIST, LBNL, Purdue University, Texas A&M University, University of Colorado, etc.)	
Peak Demand Reduction	Yes	
Most Promising Applications	Energy-intensive buildings with complex HVAC systems and with significant potential revenue loss associated with equipment malfunction and failure.	
Technology "Next Steps"	<ul style="list-style-type: none"> • Focus on the commercialization of products incorporating diagnostic capabilities by mainstream manufacturers of HVAC equipment, controls, or building energy management systems. • Rigorous quantification of benefits 	

4.15.2 Background

A wide range of diagnostic systems have been proposed, researched, developed, and/or commercialized. The common thread in all of these systems is monitoring of equipment to determine whether it is operating properly or needs service. Some examples include the following:

1. Electronic controllers programmed for Maximum and Minimum values of key control parameters, with notification of operators regarding “alarm” conditions when they occur.
2. Facilities connected to Building Energy Management Systems (BEMS) to allow observation of key operating parameters for major equipment. For instance, PC-based programs that obtain data from BEMS and provide user-friendly access to the data. These programs can assist building operators to ensure proper equipment operation by: (a) easily-viewable graphic displays, (b) plotting of data trends, (c) comparison of actual and modeled building operation, etc.
3. Computer programs that perform active analysis of building operating data received from a BEMS to determine possible equipment malfunctions.
4. Enhanced communications interfaces to improve access to data. These include BACNet and other approaches to interoperability of building equipment controls, private networks connecting buildings to central management locations, wireless communications, etc.
5. Algorithms built in to electronic controllers that provide analysis of equipment operating parameters.
6. Add-on systems which incorporate sensors and electronic processors to collect equipment operating data and assess whether the equipment require repair or maintenance. Such systems would not rely on equipment controllers for data and could therefore be used with existing equipment, particularly with equipment controlled by conventional electro-mechanical controls.

Such systems save energy by alerting building operators of malfunctions and other conditions which result in inefficient equipment performance but are not severe enough to be noticed. The problem is resolved long before it would be discovered by routine maintenance or occupant discomfort, thus reducing the total time of operation in the inefficient mode.

A number of processes or algorithms have been proposed and developed for detection of faults and or need for maintenance in a variety of HVAC equipment types; some examples appear in Table 4-42. The table is illustrative of the considerable work that has gone in to developing these techniques, but is by no means exhaustive in terms of equipment type, faults, or diagnosis approach.

Table 4-42: Fault Detection: Equipment, Faults, and Methods

Equipment Type	Faults	Diagnosis Approach	Reference Number
Air-Handling Unit	Heat Exchanger Fouling Valve Leakage	Comparison of Models and actual performance	1
		Comparison of Operation with a Fuzzy Model	2
VAV Air-Handling Unit	Return Fan Failure Supply Fan Failure CHW Pump Failure CHW Valve Stuck	Residual Method and Parameter Identification Method (using ARMAX and ARX models)	3
	Sensor Failure Pressure Sensor Failure Others	Artificial Neural Networks	4
VAV Air-Handling Unit	VAV damper stuck	ARX Models Extended Kalman Filter	5
Water-Cooled Reciprocating Chiller	Refrigerant Leak Liquid Line Restriction CW Flow Reduction CHW Flow Reduction	Modeling, Pattern Recognition, Expert Knowledge	6
Absorption Chiller	COP Degradation	Topological Case-Based Monitoring	7
Unitary Air-Conditioner	Refrigerant Leak Compressor Valve Leak Liquid Line Restriction Condenser Fouling Evaporator Fouling	Statistical Analysis of Residuals of modeled vs. actual operating parameters	8
HVAC, Lighting, etc.	A wide range of building operational problems, also including incorrect billing.	Whole Building Diagnostics	13

ARMAX: Autoregressive moving average with exogenous input

ARX: Autoregressive with exogenous input

CHW: Chilled Water

CW: Condenser Water

4.15.3 Performance

Although few good estimates of energy savings resulting from the use of automatic diagnostics are reported in the literature, extensive anecdotal evidence exists regarding the number of HVAC systems that are not operating properly. Similarly, several specific examples of diagnostics applied to simulated equipment failures exist, but an accurate determination of the level of energy use associated with this poor performance which could be avoided with automated fault detection has not been presented in the literature. Such an analysis would have to be based on a fairly large amount of data, but this data is not readily available (e.g., building operation databases exist, but many of them are either not easily available publicly or are relatively expensive to obtain). Some literature citations addressing this general question are as follows:

- Breuker and Braun [Reference 10] provide estimates of additional energy use associated with a range of common faults of unitary air-conditioning units. However, estimates of the percentage of units operating in each of the fault modes was not provided.

- EPRI Report TR-107273 [Reference 11] describes a two-year study of the energy and demand impacts of maintenance on packaged rooftop equipment. The findings were that, while operational problems were observed in the field, the energy impacts of the maintenance-related items were not significant. Improper refrigerant charge was pointed out as a problem which, while fairly common in the field, did not significantly reduce system performance. Further, the frequency of air filter changes was not found to have a large impact on system performance. In contrast, problems associated with system installation, which were not fixed at the time of installation because of a failure to carry out commissioning of the equipment, did have a significant negative impact.
- A study by the Advanced Energy Corporation⁷⁰ shows that excess energy use in *residential* split system air conditioning systems associated with poor installation or maintenance can represent as much as 40% of energy used.
- Claridge et al [Reference 13] indicated measured savings of 14% to 33% for a number of medical office buildings with simple payback period averaging about a year using Whole Building Diagnostics (WBD).
- Recent study has shown that most economizers are not working properly in the field [Reference 17].

A handful of engineers and contractors interviewed about this topic suggest that this energy “waste” is probably at least in the range of 20% to 30%. Two comments on the topic are summarized below:

- The principal of a company which performs energy conservation studies and designs energy improvements for commercial buildings indicated that more than 20% of energy use for HVAC is likely to be the result of improper equipment operation, poor installation, etc. He indicated that most of the energy savings that he has identified in his 20+ years in the business has been associated with low-cost measures to make equipment and systems operate properly, rather than capital-intensive improvements. [Reference 15]
- Another engineer suggested that well over 50% of packaged rooftop units are not operating properly. [Reference 16]

Energy use associated with different fault modes for unitary air-conditioners are presented in Table 4-43 below. Note that refrigerant leakage was reported to result in a significant increase in energy use [Reference 12], in contrast to the conclusions of the EPRI study cited above [Reference 11]. Some of the fault modes listed below do not have energy use estimates in the public literature. For these, rough reasonable estimates of energy use increase have been made (footnote 2).

⁷⁰ Information available at: www.advancedenergy.org.

Table 4-43: Estimated Increase in Cooling Energy Use for Unitary Equipment Based on Possible Fault Modes

Fault Mode	Potential Increase in Energy Use
Refrigerant Leakage (15% of Design Charge)	5.0% ¹
Liquid Line Restriction (15% Increase in Pressure Drop)	5.0% ¹
Compressor Valve Leak (15% decrease in Volumetric Efficiency)	11.0% ¹
Condenser Fouling (30% of Face Area)	8.0% ¹
Evaporator Fouling (25% Reduction in Airflow)	12.5% ¹
Improper Control Resulting in Overcooling	20.0% ²
No Economizing	10.0% ²
Failure to Switch to Minimum Outdoor Air Setting in Summer	10.0% ²
Operation at Night	20.0% ²
Condenser Fan/Motor Failure	15.0% ²

Sources: ¹Reference 12; ²TIAX Estimate.

The potential cooling energy savings for unitary air-conditioning systems by using diagnostic systems would depend on the frequency of the above fault modes in typical equipment and the extent to which the diagnostic systems would eliminate or reduce operating in fault modes. In order to determine national energy savings potential, all the applicable equipment types must be analyzed for fault modes and savings potential for reducing fault mode operation. At present, accurate information allowing such an estimate is not publicly available.

An illustration of diagnostic system energy savings is presented for a fast food restaurant in Table 4-44 [Reference 9]. This is a 1,500ft² restaurant with separate rooftop units serving the dining and the kitchen areas. Validity of the illustrated scenario depends on the potential savings that a diagnostic system would deliver.

Table 4-44: Energy Savings Potential for a Fast-Food Restaurant (Illustrative, from Reference 4)

Equipment	Annual Baseline Energy Use	Percent Savings	Annual Savings
Electric			
Rooftop Units (Cooling)	12,000 kWh ^a	20%	2,400 kWh
Rooftop Units (Ventilation)	4,000 kWh ^b	25%	1,000 kWh
TOTAL			3,400 kWh
Electric Energy Cost Savings			\$238
Natural Gas			
Rooftop Units (Heating)	180 MMBtu ^a	15%	27 MMBtu
Natural Gas Energy Cost Savings			\$149
Total Energy Cost Savings			\$387

Sources and Notes:

^a Estimated for 1,500 sqft Fast Food Restaurant using building load models developed by Lawrence Berkeley National Laboratory based on building models presented in Huang (1990), assuming 0.7cfm/sqft fresh air delivery during occupied hours and seasonal equipment efficiency of 7.5EER.

^b Operation of 3hp blower for 1,800 hours of the year when no cooling is required.

4.15.4 Cost

A wide range of implementation scenarios can be conceived for system diagnostics for HVAC equipment, as described above. The lowest cost approach is to integrate diagnostic

capability into a system’s electronic controls, a practice that has become the norm for some HVAC equipment, such as centrifugal chillers, but not for all equipment. Even if diagnostics capability is integrated with equipment controllers, it requires a more sophisticated approach to address faults in HVAC system operation, since systems incorporate a range of equipment types. Applying diagnostics to existing equipment or new equipment without electronic control requires the use of add-on systems consisting of sensors, communications interfaces, and microprocessors. In addition, the communications approach selected for a diagnostics installation will also have a significant impact on the cost. Overall, several factors must be considered in evaluating the cost of system diagnostics.

- Is the diagnostics capability built in to the electronic control that would be provided with the equipment, or does it represent additional hardware and software?
- What types of faults will the system identify, and with what level of precision?
- What is the approach for notification of building operators and/or corrective action?
- How complex is the HVAC system?

An estimate of the installation cost and economics (based solely on energy cost reduction) for system diagnostics for the fast food restaurant described above is summarized in Table 4-45 [partially based on Reference 9]. The system assumes use of a stand-alone system (i.e. it is not integrated with existing HVAC system controllers) with wireless communication to a central building location, and internet communication to a service contractor location. The sensor nodes collect measurements from a number of sensors and transmit the data via wireless communications to the hub, which is connected to the internet. This represents but one of many possible scenarios for implementation of automated diagnostics.

Table 4-45: Diagnostic System Installation Cost and Economics for a Fast Food Restaurant

Item	Number	Per Unit Material Cost	Per Unit Installation Time (hrs)	Total Cost ^a
Sensor Nodes	2	\$100	2	\$400
Hub and Middleware	1	\$300 ^b	9	\$750
Fault Detection Computer and Software	0.02 ^c	\$4,000	-	\$80
TOTAL				\$1,230
Annual Energy Cost Savings				\$387 ^d
Simple Payback Period (years)				3.2

^a Labor cost at \$50/hour

^b Assuming that an existing computer in the facility can be used for communications.

^c Assuming that one centrally-located internet-connected computer will service 50 sites.

^d From Table 4-44 above.

The simple payback period based solely on energy cost savings for system diagnostics for this illustration of its use is just over 3 years. Note that there is significant potential to provide additional savings through reduction of equipment down time preventing the loss of revenues and the prevention of costly equipment repairs. Note also that this is a fairly sophisticated scenario for application of automated diagnostics representing relatively high costs, because: (1) it is a standalone system, and (2) it involves a fairly sophisticated

communications network for transmission of the data to a central location for analysis. On the other hand, the rate and level of faults in actual rooftop units will vary significantly from one unit to another, resulting a broad range of simple payback periods. For example, some units would have but a few minor faults with minimal energy impact, resulting in a much longer payback period.

An alternative scenario would be that the rooftop units whose energy use is the basis of the energy savings presented in Table 4-44 have electronic controllers with diagnostic capabilities. Notification of the building operators could be built in to the thermostats. Such a scenario may involve higher costs associated with electronic control, use of electronic controllers with sufficient computing power to handle the required diagnostics algorithms, and use of additional communications interface with the thermostats. Assuming that the rooftop manufacturer provides these features, the end user cost premium may be \$100 per unit. Further assuming that the savings of Table 4-44 could still be achieved, the payback period would equal about one half of a year.

4.15.5 Perceived Barriers to Market Adoption of Technology

Several market barriers have impeded the adoption of system diagnostics in the HVAC industry:

- The use of electronic controls is increasing but is not yet dominant for many equipment types. Hence, incorporation of all but the simplest diagnostic approaches requires separate systems, which represent added cost and complexity.
- The need for automated diagnostics is not recognized. Building operators would not likely admit that the equipment and systems they are responsible for could be operating improperly. Building operators who are sophisticated enough to recognize that equipment may not be installed or operating properly will likely be in a position to easily fix these problems, and hence would have less need for automated diagnostics. There may also be sensitivity among engineers and building owners to potential liability associated with information that the building's systems were not operating properly (in particular, failure to provide proper outdoor air quantities).
- The benefit of automated system diagnostics is not easily quantified. Benefits require: (a) the possibility that something might go wrong, (b) the possibility that the diagnostic system will alert the building operator, and (c) the need for the operator to fix the problem.
- Many possible approaches exist to incorporate automated diagnostics into HVAC equipment and systems and it is not clear which make the most sense from the standpoint of successful operation and good acceptance in the marketplace.

4.15.6 Technology "Next Steps"

- Study to better clarify the energy savings potential of system diagnostics: What is the frequency and degree of occurrence for the important equipment failure modes, and what is the energy impact of these modes?
- Allow marketplace forces to guide development of system diagnostics products. Manufacturers of HVAC equipment, controls, or BEMS should have lead roles in

implementation of this technology if it is to evolve into forms acceptable by the market; this implies co-development of the technology with companies of these groups willing to cooperate in such efforts.

4.15.7 References

1. Haves, P., T.I.Salsbury, J.A.Wright, 1996, "Condition Monitoring in HVAC Subsystems Using First Principles Models", ASHRAE Technical Data Bulletin, Volume 12, Number 2, Fault Detection and Diagnosis for HVAC Systems, February.
2. Dexter, A.L. and M.Benouarets, 1996, "A Generic Approach to Identifying Faults in HVAC Plants", ASHRAE Technical Data Bulletin, Volume 12, Number 2, Fault Detection and Diagnosis for HVAC Systems, February.
3. Lee, W.Y., C.Park, G.E.Kelly, 1996, "Fault Detection in an Air-Handling Unit Using Residual and Recursive Parameter Identification Methods", ASHRAE Technical Data Bulletin, Volume 12, Number 2, Fault Detection and Diagnosis for HVAC Systems, February.
4. Lee, W.Y., J.M.House, C.Park, G.E.Kelly, 1996, "Fault Diagnosis of an Air-Handling Unit Using Artificial Neural Networks", ASHRAE Technical Data Bulletin, Volume 12, Number 2, Fault Detection and Diagnosis for HVAC Systems, February.
5. Yoshida, H., T.Iwami, H.Yuzawa, M.Suzuki, 1996, "Typical Faults of Air-Conditioning Systems and Detection by ARX and Extended Kalman Filter", ASHRAE Technical Data Bulletin, Volume 12, Number 2, Fault Detection and Diagnosis for HVAC Systems, February.
6. Stylianou, M. and D.Nikanpour, 1996, "Performance Monitoring, Fault Detection, and Diagnosis of Reciprocating Chillers", ASHRAE Technical Data Bulletin, Volume 12, Number 2, Fault Detection and Diagnosis for HVAC Systems, February.
7. Tsutsui, H. and K. Kamimura, 1996, "Chiller Condition Monitoring Using Topological Case-Based Monitoring", ASHRAE Technical Data Bulletin, Volume 12, Number 2, Fault Detection and Diagnosis for HVAC Systems, February.
8. Rossi, T.M. and J.E.Braun, 1997, "A Statistical, Rule-Based Fault Detection and Diagnostic Method for Vapor Compression Air Conditioners", *International Journal of HVAC&R Research*, Volume 3, No. 1, January.
9. ADL, 2001, "Wireless, Internet-Enabled Fault Detection and Energy Monitoring Device", Proposal submitted by Arthur D. Little in response to DOE/NETL solicitation DE-PS26-01NT41092, February.
10. Breuker, M.S. and J.E.Braun, 1998, "Common Faults and Their Impacts for Rooftop Air Conditioners", *International Journal of HVAC&R Research*, vol. 4, no. 3, pp. 303-316, July.
11. EPRI, 1997, "The Impact of Maintenance on Packaged Unitary Equipment", EPRI Report TR-107273, abstract at http://www.epri.com/OrderableItemDesc.asp?product_id=TR-107273, February.
12. Breuker, M., Rossi, T., Braun, J., 2000, "Smart Maintenance for Rooftop Units." *ASHRAE Journal*, November, pp. 41-47.
13. Claridge, D., Liu, M., and Turner, W.D., 1999, "Whole Building Diagnostics", Workshop held 16 and 17 June at the Pacific Energy Center. Available at: <http://poet.lbl.gov/diagworkshop/proceedings/> .

14. Huang, J., Hashem, A., Rainer, L., and Ritschard, R., 1990, “481 Prototypical Commercial Buildings for Twenty Urban Market Areas”, Lawrence Berkley Laboratory for the Gas Research Institute, GRI Report 90/0326, June.
15. Donahue, J.L., 2001, Personal Communication, Energy Planning, Inc., January.
16. Shapiro, A., 2001, Personal Communication, Taitem Engineering, January.
17. Energy Design Resources, 2002, “Economizers Design Brief”. Available at http://www.energydesignresources.com/publications/design_briefs/pdfs/VOL_02/DB-Economizers.pdf .

4.16 Variable Refrigerant Volume/Flow

4.16.1 Summary

Variable Refrigerant Volume, or VRVTM, systems are ductless commercial HVAC systems that can be configured in a highly flexible manner by matching numerous (e.g., up to 16) indoor evaporator units of varying capacity and design with a single condensing unit. Currently widely applied in large buildings such as offices and hospitals outside the U.S., especially in Japan and Europe, these systems are just starting to be introduced in the U.S. The systems use multiple compressors, including inverter-driven variable speed units, and deliver excellent part-load performance and zoned temperature control, resulting in excellent occupant comfort. Both installed costs and energy operating costs are highly application dependent, and current simulation tools are probably inadequate to accurately capture the true energy savings potential of VRVTM systems. The most effective way to address these cost and performance issues would be to perform rigorous field tests comparing them to the best available conventional systems in various real-world buildings and operating conditions.

Table 4-46: Summary of VRV™/VRF System Characteristics

Characteristic	Result	Comments
Technical Maturity	Current	Widely available outside the U.S., especially in Japan and Europe, but just starting to be introduced in the U.S.
Systems Impacted by Technology	Commercial HVAC Systems	Best applications are office buildings, schools, hotels, hospitals, and other multi-room commercial buildings
Readily Retrofit into Existing Equipment/Buildings?	Depends on Building	Excellent for retrofits of buildings with no air conditioning or landmark or historical buildings where duct installation is difficult or expensive. Where chillers and associated water piping already exist, a VRV™ retrofit would be much more expensive than a replacement chiller.
Relevant Primary Energy Consumption (quads)	2.2 Quads	Portion of commercial space conditioning applicable to buildings where VRV™ is potentially attractive.
Technical Energy Savings Potential (quads)	0.3 Quads	Assumes overall 15% savings, but actual savings vary according to particular application. Savings potential and break-down highly uncertain.
Approximate Simple Payback Period	Highly application-dependent	Depends on climate, building design, and electricity cost. True market costs for the U.S. are still uncertain since products are not yet available in commercial quantities.
Non-Energy Benefits	Comfort, Size, Weight, Design Flexibility, Noise	Enhanced comfort due to reduced temperature variation that is made possible by variable speed compressors and PID control. Temperature variations can be held to +/- 2°F, less than half that of conventional systems. Smaller and lighter than comparable rooftop systems or chillers of similar tonnage, thus enabling easier installation (e.g. condensing units fit into elevators, thus eliminating the need for cranes or helicopters; no extra roof reinforcement) and avoiding the need for a dedicated machine room. Design flexibility is due to the ability to use various indoor units of different capacity and design, as well as the system's modularity that enables conditioning of parts of the building as they are occupied during construction or renovation and easy adaptation to changes in room layout. Modularity also permits partial system operation even if a single unit fails. Reduces noise by eliminating central station air handlers.
Notable Developers/Manufacturers of Technology	Daikin-Trane, Mitsubishi, Toshiba-Carrier, Hitachi, Samsung	Primarily Japanese manufacturers, in some cases with American partners.
Peak Demand Reduction	Possible	Reduces energy required for air distribution.
Most Promising Applications	Office buildings, schools, hotels, hospitals and other multi-room buildings with irregular room sizes. Landmark or historical buildings where duct installation is difficult or expensive. Southern climates where heating loads are modest.	
Technology "Next Steps"	Demonstration programs, including rigorous monitoring of energy savings. Development of integrated system with gas heating capabilities.	

4.16.2 Background

Variable Refrigerant Volume, or VRV™, systems (referred to as Variable Refrigerant Flow or VRF systems by many manufacturers) were introduced in Japan in 1982 and have since been deployed throughout the world, with the notable exception of North America, where VRV™ market penetration is negligible. These systems are basically very large capacity

versions of the ductless multi-split systems that have achieved a niche market in the U.S. The basic difference between these systems and conventional HVAC systems is that they circulate refrigerant directly to multiple evaporator units, rather than using water (as in a chiller) or air (as in a ducted DX system) to achieve heat transfer to the space. VRVTM systems are extremely flexible, enabling a single condensing unit to be connected to a large number of indoor units of varying capacity and configuration, as shown schematically in Figure 4-24. The exact number of indoor units varies according to the manufacturer, but one typical manufacturer allows connection of up to 16 indoor units to one condensing unit, or up to 30 indoor units on a single refrigerant circuit supplied by 3 outdoor units. Typically, each condensing unit uses 2 or 3 compressors, one of which is an inverter-driven variable speed compressor. Systems are commonly designed by combining multiple condensing units to achieve system capacities of up to several hundred tons.

Energy savings are due to several factors:

- **High Part-Load Efficiency:** Because VRVTM systems consist of multiple compressors, some of which are variable speed, the system's part-load efficiency is excellent. A typical dual compressor system can operate at 21 capacity steps. Since most HVAC systems spend most of their operating hours between 30-70% of their maximum capacity, where the COP of the VRVTM is very high, the seasonal energy efficiency of these systems is excellent.
- **Effective Zone Control:** Indoor units can easily be turned off in locations needing no cooling, while the system retains highly efficient operation. An excellent example of such an application is described in [1]. In that example, a municipal building where much of the space is unoccupied during much of the day when workers are out in the field. A side-by-side comparison of a rooftop VAV and a VRF, showed energy savings of approximately 38% for the VRF, though the exact details of the testing are unpublished, so it is uncertain whether the test was a true "apples-to-apples" comparison.
- **Heat Recovery Operation:** An option in buildings where simultaneous heating and cooling is needed, such as many office buildings, is a 3-pipe heat recovery system. In this type of system, refrigerant flow control is used to circulate refrigerant from the discharge of the evaporators in space being cooled to the evaporators of zones needing heat and visa-versa (see Figure 4-24). By using refrigerant to move heat between zones, a very high COP can be realized.

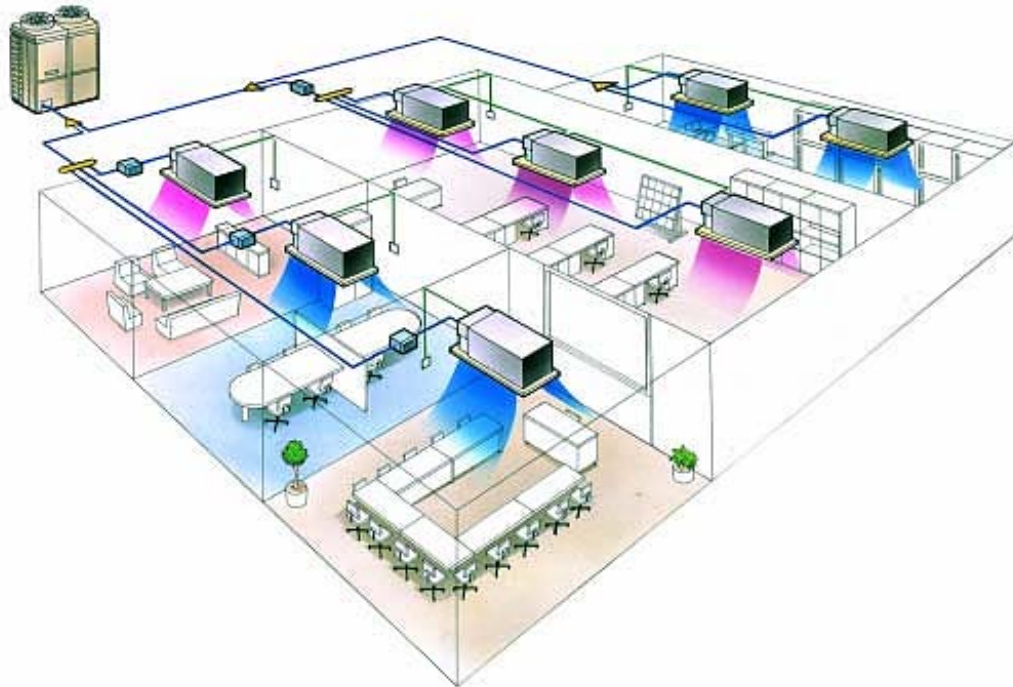

Figure 4-24: Schematic Diagram of VRV™ System with Heat Recovery (from Daikin Industries Ltd.)

4.16.3 Performance

Because the energy savings of VRV™ systems are so application dependent, it is difficult to make definitive, general statements about their energy efficiency. Simulations often fail to take into account actual behavior in a building, as well as many relevant factors such as distribution system losses. Field tests often compare the newest VRV™ technology to older conventional systems that they replaced. Reference [1] found 38% energy savings relative to a rooftop VAV in that particular installation. Reference [2], a full year, hourly simulation, compared a 538 ton VRV™ to the both screw and centrifugal chillers (2 x 240 tons) of the most recent designs. The energy savings of the VRV™ were very impressive in the moderate Brazilian climate, ranging from about 30% in summer to over 60% in winter. These savings seem unusually high and are attributed to the high part load efficiency of the VRV operating in the very moderate climate. Simulations in the U.S. are ongoing, and the current simulation tools are probably inadequate. Initial estimates of energy savings relative to conventional systems are in the range of 5-15%, with higher savings in hot humid climates and lower savings in cold climates due to the advantage of gas heating in colder climates. The only way to address the true energy savings potential of VRV™ systems will be to perform rigorous field tests comparing them to the best available conventional systems in real-world operating conditions.

4.16.4 Cost

Installed costs are highly dependent on the building construction and whether the installation is new or a retrofit. Generally speaking, the equipment cost of a VRV™ system will be higher than that of a comparable DX rooftop or a chiller, but the installation cost

may be lower, particularly if ducting is difficult to install. Because VRVTM systems are not currently being sold in commercial quantities in the U.S., there is no true market price, and costs in overseas markets vary due to many factors such as import tariffs and local regulations. Currently, estimates of the installed cost premium of a VRVTM range from about 5-20% over conventional systems for a single U.S. office building. In [2], a case study of a 17 floor, 100,000 ft² office building in Brazil, the installed cost premium of the VRVTM was about 15-22% relative to chiller options, but this comparison is skewed by high import tariffs for the VRVTM. The net present value, accounting for capital and energy costs, was about 6-10% better for the VRV using a 10% discount rate over 10 years. Electricity rates were comparable to U.S. rates. In [3], a case study of a 43,000ft² German hotel, the costs of a VRVTM and an air-cooled screw chiller were nearly identical. In that case, the costs for the indoor and outdoor units of the VRVTM were approximately 43% higher than for the chiller, but savings on insulation, valves and installation made up the difference. The net result of this uncertainty is that cost comparisons between a VRVTM and other systems are highly application dependent and need to be evaluated on a case-by-case basis.

4.16.5 Perceived Barriers to Market Adoption of Technology

Several barriers exist to the adoption of VRVTM /VRF systems in the U.S., even though these systems are now well established in all other regions of the world. The key barriers are described below:

First Cost: In most cases, a VRVTM system has a higher initial cost than other options such as a chiller or rooftop system. Furthermore, customers expect chillers to run 20-30 years, while a VRVTM /VRF is assumed by contractors to be comparable to other DX systems which have a life of only 10-20 years, thus increasing overall life-cycle costs. The costs associated with a separate gas-fired heating system for the VRVTM are also higher than for other systems. For retrofits or replacements of chillers, where a water loop is already in place, installing a VRVTM would be more expensive than simply replacing the chiller, except in cases where total renovation down to the building shell occurred.

Reliability and Maintenance: Although suppliers claim that VRVTM /VRF systems are very reliable, contractors and engineers believe that a VRVTM /VRF system with many compressors (e.g. 20 compressors for 100 tons of cooling) is inherently less reliable than a chiller which has a smaller number of compressors (e.g. 1-4 compressors for 100 tons). However, it is also acknowledged that this is an advantage of the VRVTM /VRF since, unlike a chiller, a failure of a single compressor would have limited impact on the system's ability to function. Heat pump systems are also regarded as inherently less reliable than gas heating systems. One reason is that heat pumps operate year-round, under a severe duty cycle, while a cooling-only system operates only a few months a year. The maintainability of long refrigerant lines is also questioned by many contractors, who are more familiar and comfortable with water loop maintenance (more below).

Lack of an Integrated Gas Heating Option: There are no systems currently available with gas heat, although such systems are in the development/demonstration phase. In Northern

climates, customers would not accept heat pumps, even if they were rated for low temperature operation, due to the perceived (and often actual) energy efficiency handicaps. It is possible to have a separate gas or oil heating system, in addition to the cooling-only VRVTM/VRF, but the cost would be higher than other integrated heating/cooling options such as a rooftop system with gas heat or a chiller/boiler system.

Long Refrigerant Piping Runs: This is a major maintenance concern since contractors believe that refrigerant leaks are hard to find and cumbersome to repair, particularly when the lines run through inaccessible spaces. Although the system could meet ASHRAE Standard 15 safety requirements and would therefore be acceptable to building code authorities, there is a perception of increased liability exposure due to the large volume of refrigerant present in the system and long runs through occupied spaces. All of these issues have been sufficiently addressed in Europe, Asia, and Latin America, but a major education campaign is necessary to change the perceptions of contractors and engineers.

OEM Support/Brand Name and Reputation: The developers and manufacturers of VRVTM/VRF systems are Japanese and Korean companies with limited name recognition and technical support structures in the U.S. However, now that at least two of the leading Japanese manufacturers have entered into strategic alliances with leading U.S. manufacturers, these barriers may be mitigated.

4.16.6 Technology “Next Steps”

As noted above, VRVTM/VRF systems has substantial energy-related and non-energy advantages over other systems in many cases. The barriers to adoption in the U.S. initially existed in other regions of the world and have been overcome through demonstration of the technology’s benefits and education of contractors and engineers. The energy benefits of these systems are very application specific and can not be proven through simple efficiency ratings. Complex computer simulations can show energy savings, but such simulations are often viewed with skepticism by engineers who believe they can be skewed by the assumptions of the manufacturers. Therefore, the next step in accelerating market adoption of this technology would be rigorous demonstration and monitoring programs to demonstrate the claimed advantages, particularly energy cost savings, and to understand the true installed costs and the importance of other barriers to commercialization in the U.S. These demonstrations would need to encompass different building types and climates. Another important step would be the development of a cost-effective product integrating the VRVTM with gas heating.

4.16.7 References:

1. Nye, H., 2002, “Digital Variable Multi A/C Technology Passes Test,” Air Conditioning, Heating, & Refrigeration News, 14 January.
2. Interact, 2002, “Estudo comparativo de alternativas de climatizacao para o predio Cardoso de Mello” (Comparative Study of Alternative Air Conditioning Systems for Predio Cardoso de Mello), prepared by Interact Ltda. of Brazil for DK Air Condicionado Ltda., February.

3. Daikin Europe NV, 2001, “Case Study of VRV™ and Chiller for Hotel Application in Germany”, Unpublished Presentation by Daikin Industries, Ltd.

5 CONCLUSIONS

Based on surveys of the HVAC literature, this study originally identified 170 technology options that could potentially reduce the energy consumption of HVAC systems in commercial buildings. After developing first-cut energy savings potential estimates for each option, 55 options were selected for further study in consultation with a range of HVAC experts. Each of the 55 options received further study, including more detailed investigation of their technical energy savings potential, current and future economics (cost), barriers to achieving their full market potential, and developmental “next steps” for each technology. An appendix (Appendix A) contains the summaries for the forty options not chosen for more refined study, each about two pages in length. Many of the 40 technologies have significant technical energy savings potentials (see Figure 5-1).

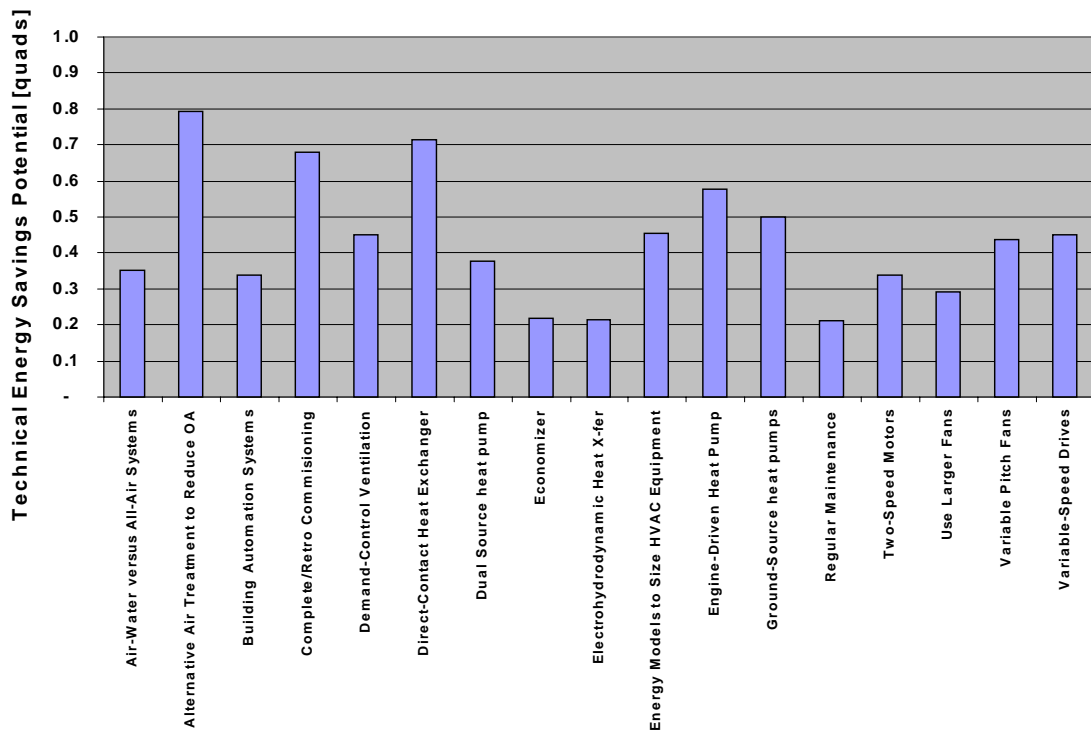

Figure 5-1: Estimated Technical Energy Savings Potential of Technology Options not Selected for 15

Many of the 15 technologies selected for refined study have significant technical energy savings potential, combined with attractive or reasonable simple payback periods (see Figure 5-2). Three of the options, Novel Cool Storage, Variable Refrigerant Volume/Flow, and Adaptive/Fuzzy Control, had highly variable simple payback periods that did not readily translate into an average simple payback period, while the simple payback period for Microenvironments exceeded 100 years.

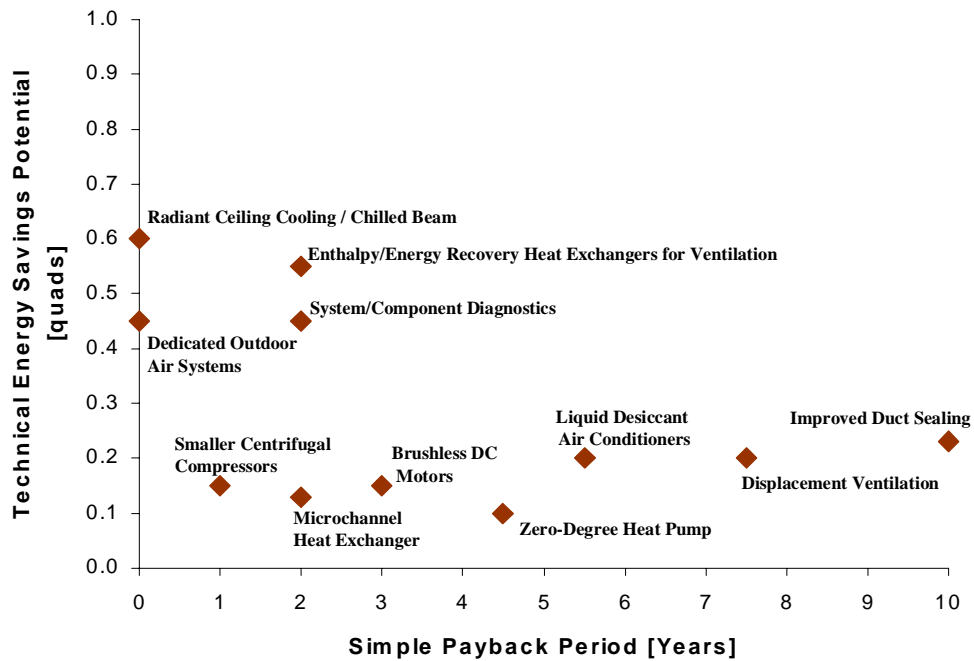

Figure 5-2: Estimated Technical Energy Savings Potential and Simple Payback Periods for the 15 Options

Overall, some common themes arise as to how the 15 technologies reduce energy consumption (see Table 5-1).

Table 5-1: Common Themes to Energy Consumption Reduction

Energy Consumption Reduction Theme	Relevant Technologies
<i>Separate Treatment of Ventilation and Internal Loads</i>	<ul style="list-style-type: none"> • Dedicated Outdoor Air Systems (DOAS) • Radiant Ceiling Cooling • Liquid Desiccant for Ventilation Air Treatment • Energy Recovery Ventilation • Displacement Ventilation
<i>Fix Common HVAC Problems</i>	<ul style="list-style-type: none"> • Adaptive/Fuzzy Control • Improved Duct Sealing • System/Component Diagnostics
<i>Improved Delivery of Conditioning Where Needed</i>	<ul style="list-style-type: none"> • Microenvironments • Displacement Ventilation • Variable Refrigerant Volume/Flow • Adaptive/Fuzzy Logic Control
<i>Improved Part-Load Performance</i>	<ul style="list-style-type: none"> • Electronically Commutated Permanent Magnet Motors • Smaller Centrifugal Compressors • Variable Refrigerant Volume/Flow

Several of the 15 share common non-energy benefits that enhance their commercial potential, notably down-sizing of HVAC equipment, enhanced indoor air quality (IAQ), improved humidity control, and significant peak demand reduction (see Table 5-2).

Table 5-2: Common Non-Energy Benefits of the 15 Technology Options

Non-Energy Benefit	Relevant Technologies
<i>Down-Sizing of HVAC Equipment</i>	<ul style="list-style-type: none"> • Dedicated Outdoor Air Systems (DOAS) • Radiant Ceiling Cooling • Enthalpy/Energy Recovery Exchangers for Ventilation • Displacement Ventilation • Novel Cool Storage • Liquid Desiccant Air Conditioner for Ventilation Air Treatment. Variable Refrigerant Volume/Flow
<i>Enhanced Indoor Air Quality</i>	<ul style="list-style-type: none"> • Displacement Ventilation • Liquid Desiccant Air Conditioner
<i>Improved Humidity Control</i>	<ul style="list-style-type: none"> • Dedicated Outdoor Air Systems (DOAS) • Enthalpy Recovery Exchangers for Ventilation • Liquid Desiccant Air Conditioner
<i>Notable Peak Demand Reduction</i>	<ul style="list-style-type: none"> • Novel Cool Storage • Dedicated Outdoor Air Systems • Enthalpy/Energy Recovery Exchangers for Ventilation • Improved Duct Sealing • Radiant Cooling / Chilled Beam • Variable Refrigerant Volume/Flow

Owing to the range of technology status of the different options, the options have a wide range of “next steps” (see Table 5-3).

Table 5-3: Technology Development Potential “Next Steps” for the 15 Technologies

Potential “Next Step”	Relevant Technologies
<i>More Research and/or Study</i>	<ul style="list-style-type: none"> • Adaptive/Fuzzy Logic Control • Heat Pump for Cold Climates (CO₂ cycle) • Liquid Desiccant Air Conditioner • Small Centrifugal Compressor • System/Component Diagnostics
<i>Education</i>	<ul style="list-style-type: none"> • Dedicated Outdoor Air Systems (DOAS) • Displacement Ventilation • Enthalpy/Energy Recovery Exchangers for Ventilation • Radiant Ceiling Cooling • Variable Refrigerant Volume
<i>Demonstration</i>	<ul style="list-style-type: none"> • Displacement Ventilation • Improved Duct Sealing • Radiant Ceiling • Variable Refrigerant Volume/Flow
<i>Market Conditioning, etc.</i>	<ul style="list-style-type: none"> • Electronically Commutated Permanent Magnet Motors • Enthalpy/Energy Recovery Exchangers for Ventilation • Microchannel Heat Exchangers

Several factors characterize the most promising areas for the application of the 15 technology options, and HVAC energy-efficiencies in general. First, the economics of energy-efficient equipment improve in regions with high electricity and gas rates. For cooling and ventilation technologies, higher demand charges can also result in shorter simple payback periods. Second, as noted in ADL (1999), packaged rooftop equipment presents several opportunities for more cost-effective efficiency gains due to the lower efficiency equipment typically employed⁷¹. Third, institutional purchasers (governments, hospitals, educational establishments, etc.) tend to have a longer time horizon than most commercial enterprises, reducing their sensitivity to first-cost premium and making HVAC technologies with reasonable payback periods more attractive. Fourth, in many instances hospitals should be a preferred building type for more efficient equipment and systems, as they consume high levels of HVAC energy because of ‘round the clock operations and high OA requirements, and are often long-standing institutions willing to invest more funds up front provided they reap a solid return over the equipment lifetime.

Finally, many of the 15 options could be readily retrofit into existing equipment or buildings, increasing the rate at which they could achieve significant market penetration.

⁷¹ The joint DOE/EPA Energy Star® program recently began investigation of a program in light commercial HVAC. For more information, see: <http://yosemite1.epa.gov/Estar/consumers.nsf/content/lighthvac.htm> .

REFERENCES

ADL, 1999, "Energy Consumption Characteristics of Commercial Building HVAC Systems – Volume II: Thermal Distribution, Auxiliary Equipment, and Ventilation", Final Report to the U.S. Department of Energy, Office of Building Technology, State and Community Programs, October. Available at:

<http://www.eren.doe.gov/buildings/documents/pdfs/comhvac.pdf> .

ADL, 2001, "Energy Consumption Characteristics of Commercial Building HVAC Systems – Volume I: Chillers, Refrigerant Compressors, and Heating Systems", Final Report to US Department of Energy, Office of Building Technology, State and Community Programs, April. Available at:

<http://www.eren.doe.gov/buildings/documents/pdfs/hvacvolume1finalreport.pdf> .

ASHRAE, 1999, "ASHRAE/IESNA Standard 90.1-1999: Energy Standard for Buildings Except Low-Rise Residential Buildings", ASHRAE Press: Atlanta, Georgia.

BTS, 2001, "2001 BTS Core Data Book", Office of Building Technology, State and Community Programs. Available at: <http://btscoredatabook.eren.doe.gov/> .

Cler, G. et al., 1997, **Commercial Space Cooling and Air Handling: Technology Atlas**. E Source, Inc.

De Saro, R., 2001, "The Origin of Innovation: Where do New Technologies Come From?", *Energy User News*, June, 2001, pp. 18-24.

DeCanio, S.J., 1994, "Why do Profitable Energy-Saving Investment Projects Languish?". *J. Genl. Mgt.*, vol. 20, no.1, Autumn, 1994.

EIA, 1999, "Commercial Buildings Energy Consumption Survey (CBECS), Energy Information Administration, U.S. Department of Energy. Available at:

<http://www.eia.doe.gov/emeu/cbecs/contents.html> ; new construction data from: <http://www.eia.doe.gov/emeu/cbecs/pdf/b8.pdf> .

Fisk, W.J., 2000, "Health and Productivity Gains from Better Indoor Environments and their Relationship with Building Energy Efficiency", *Annual Review of Energy and the Environment*, vol. 25, pp. 537-566.

Hawken, P., Lovins, A., and Hunter Lovins, L., 1999, **Natural Capitalism**, Back Bay Books: Boston, Massachusetts.

HVAC&R News, 1997, "A/C Equipment Efficiency", *Heating, Ventilation, Air-Conditioning and Refrigeration News*, 10 November, p.3.

RLW Analytics, 1999, "Final Report: Non-Residential New Construction Baseline Study", California State-Level Market Assessment and Evaluation Study, July.

APPENDIX A: DATA SHEETS FOR 40 TECHNOLOGIES STUDIED IN MORE DETAIL

Appendix A contains the write-ups for the 40 technologies studied in more detail but not selected as one of the 15 options receiving more refined study. Each entry begins with an overview of the technology, followed by entries on the following aspects of the technology option:

- Technical Maturity;
- Systems/Equipment Impacted by Technology;
- Readily Retrofit into Existing Equipment and Buildings;
- Total Primary Energy Consumption by Systems/Equipment Impacted by Technology;
- Performance Information/Data and Source (overall summary and brief summary of information for each source);
- Cost Information/Data and Source (overall summary and brief summary of information for each source);
- Non-Energy Benefits of Technology;
- Notable Developers/Manufacturers of Technology;
- Peak Demand Reduction;
- Most Promising Opportunities for Technology, Location(s) and Application(s);
- Perceived Barriers to Market Adoption of Technology;
- Technology “Next Steps”;
- References.

Appendix A - Table of Contents

Technology Option	Page #
Advanced Compressors	A-3
Advanced Desiccant Materials for Desiccant Dehumidification	A-6
Airfoil and Backward-Curved Centrifugal Blowers	A-8
All-Water Thermal Distribution Systems	A-12
Alternative Air Treatment	A-14
Apply Building Energy Software to Properly Size HVAC Equipment	A-17
Building Automation Systems/Building Energy Management Systems	A-21
Chemical Exothermic/Endothermic Heat/Cool Generation	A-25
Complete (New Building) and Retro-Commissioning	A-27
Copper Rotor Motors	A-32
DDC Finite State Machine Control Algorithms	A-35
Direct-Contact Heat Exchanger	A-38
Dual-Compressor Chillers	A-41
Dual-Source Heat Pump	A-44
Ductless Split Systems	A-47
Economizer	A-50
Electrohydrodynamic (EHD) Heat Transfer	A-54

Electrostatic Precipitators	A-58
Engine-Driven Heat Pump	A-61
Geothermal (Ground-Coupled and Ground-Source) Heat Pumps	A-65
Heat Pipes (heat Recovery and Wrap-Around Coil Applications)	A-70
High-Efficiency Fan Blades: Optimized Blade for Each Applications	A-74
High-Temperature Superconducting Motors (HJTSM)	A-76
Hydrocarbon Refrigerants	A-79
IAQ Procedure/Demand-Control Ventilation	A-83
Larger Diameter Blowers and Fans	A-88
Low-Pressure Refrigerant Cycles	A-91
Mass Customization of HVAC Equipment	A-94
Microscale Heat Pipes	A-97
Modulating Boilers and Furnaces	A-99
Natural Refrigerants – Ammonia/CO ₂ /Water Refrigeration Cycles	A-102
Phase Change Insulation/Ceiling	A-107
Refrigerant Additives to Enhance Heat Transfer	A-111
Regular Maintenance	A-114
Twin-Single Compressors	A-120
Two-Speed Motors	A-123
Variable-Pitch Fans	A-126
Variable-Speed Drives	A-129
Zeotropic Refrigerants	A-134

Technology Option: Advanced Compressors

Description of Technology: A linear compressor is similar to a reciprocating compressor, but uses a linear motor to drive the compression piston instead of a standard motor with a cam (reciprocating compressor). Copeland's digital scroll compressor modulates refrigerant by closing a valve to prevent refrigerant from moving through the system while the scrolls continue to orbit, effectively unloading the compressor for that period. By varying the time window during which the compressor pumps refrigerant, it achieves modulation from 17-100% of full load (JARN, 2000).

Description of How Technology Saves Energy: Linear compressors offer the potential for superior performance to reciprocating compressors because they can readily and efficiently modulate their capacity (i.e., the length of the linear compression) to achieve part-load efficiencies very close to full-load levels. Variable- and multi-speed compressors allow part-load matching, which greatly reduces cycling losses suffered by single-speed compressors and improves the SEER of air-conditioning units. Also, the linear compressor uses a permanent magnet motor, which has much higher efficiency than induction motors at smaller sizes, while the free piston design reduces friction losses and eliminates crank shaft losses (total decrease ~50% according to Lee et al., 2000). Finally, part-load operation results, in effect, in larger heat exchangers which decreases approach temperatures and improves COP further.

Technology Technical Maturity: New. LG (Korea) will launch linear compressors in refrigerators, probably this year (Unger, 2001), with plans to explore RAC-sized units); current (variable- and multi-speed, for some larger HVAC). Copeland's digital scroll is currently available.

Systems/Equipment Impacted by Technology: All vapor compression cycles, in sizes of 10 tons or less.

Readily Retrofit into Existing Equipment and Buildings: No.

Total Primary Energy Consumption by Systems/Equipment Impacted by Technology: 0.31 Quads; Based on 5-10 ton unitary AC and HP, RAC, and PTAC, per Unger (2001), who envisions use of linear compressor in size of up to 10kW (Electric), or peak of ~35kW cooling (~10 tons).

Performance Information/Data and Source:

Summary: Both linear and digital scroll compressors offer seasonal energy efficiency gains similar to that of variable-speed drives in compressor applications, i.e., ~20-30%. In their applicable HVAC range, linear compressors also yield another ~15% improvement, primarily by virtue of increased compressor efficiency, for a total improvement of ~35%.

Lee et al. (2000): For household refrigerators, linear compressors are ~20-30% more efficient than crank-driven compressors (reciprocating), in large part due the permanent magnet (PM) motor (~90% efficient in small sizes). The PM motor allows modulation down to ~50% capacity, with no change in performance, with an overall efficiency of ~80% of theoretical.

TIAX Assessment: The magnitude of the linear motor efficiency gain (versus conventional induction motors) decreases for air-conditioning systems applications, particularly those using integral HP motors for compressors. In the 5-ton range, air-conditioning compressors typically have 60 to 65% efficiency (up to 70%), which decreases the advantage of the linear compressor to about 15%.

Unger (1998): The gain in efficiency from a linear compressor is greatest at lower compressor pressures and decreases at higher pressures (i.e., higher temperatures, too.).

ADL (2000): In a 10-ton unitary A/C unit, seasonal simulations show that the Copeland Digital Scroll compressor will result in ~8% reduction in total annual energy consumption relative to a baseline VAV unit.

Cost Information/Data and Source:

Summary: Linear compressors may have ~20% cost premium over reciprocating compressors; however, to realize the benefits from modulation, they will require additional controls which are quite costly. Assuming quite favorable energy savings, a linear compressor in a 5-ton A/C application has a payback period of at least 4 years. The digital scroll compressor's simple payback period in a unitary A/C application exceeds 11 years.

TIAX Analysis: A 5-ton unit where a linear compressor replaces a 5-ton conventional compressor, it will have more than a 100% cost premium relative to the conventional 5-ton compressor (due to the cost of the variable speed drive, estimated from the ADL (2000) cost for a ~2hp VSD drive). Using the ADL (2001) estimate of annual cooling energy consumption of ~3.9kW-h/ft²/year, an electricity rate of \$0.07/kW-h, and assuming an annual cooling energy reduction of 32%, the linear compressor would have a simple payback period of ~4 years. However, all of these gains may not be realized in practice, as part-load operation reduces the ability of the unit to manage humidity and would result in decreased part load operation, as well as decreased benefit in modulating cycle efficiency (because only the condenser - and not the evaporator - approach temperature differences could decrease). At sizes larger than 5 tons, unitary equipment typically employs multiple compressors (e.g., a 10-ton unit using two 5-ton compressors) which achieve most of the benefits of a linear compressor without the price premium for the variable speed drive and controls.

Unger (2001): Linear compressors currently have ~20% cost premium over conventional compressors.

ADL (2000): Copeland's Digital Scroll, applied in a 10-ton unitary unit, has an OEM cost premium of ~\$500 relative to a baseline system, translating into a payback period of more than 11 years.

Non-Energy Benefits of Technology: Modulation reduces temperature swings and improves occupant comfort. Quieter operation. Less wear due to elimination of crankshaft, decreased piston friction.

Notable Developers/Manufacturers of Technology: Copeland (Digital Scroll), Sunpower (Linear).

Peak Demand Reduction?: Depends; the higher efficiency of linear compressors at peak conditions will reduce peak demand; the digital scroll does not offer peak demand reduction.

Most Promising Opportunities for Technology, Location(s) and Application(s): Buildings and regions with high air-conditioning loads.

Perceived Barriers to Market Adoption of Technology: Appliance manufacturers adjusting their product designs to incorporate new components/technologies. First cost. Uncertainty about product reliability.

Technology "Next Steps": Demonstration and verification of cost/energy savings.

References:

ADL, 2000, "Energy Efficient Rooftop Air Conditioner: Continuation Application Technical Progress Statement", Presentation on 7 November, Project #: DE-FC26-99FT40640.

JARN, 2000, "Copeland Digital Scroll™ Unveiled", *JARN*, 25 September, p. 1,15.

Lee, H, Song, G., Park, J.-S., Hong, E., Jung, W., Park, K., 2000, "Development of the Linear Compressor for a Household Refrigerator," *Proceedings of the 15th International Compressor Conference at Purdue University, West Lafayette, IN, 25-28, July*, pp. 31-38.

Unger, R.Z., 1998, "Linear Compressors for Clean and Speciality Gases", *Proceedings of the 1998 International Compressor Engineering Conference*, Purdue University, West Lafayette, IN, 14-17 July.

Unger, R.Z., 2001, Personal Communication, Sunpower Corp.

Technology Option: Advanced Desiccant Materials for Desiccant Dehumidification

Description of Technology: At present, most desiccant systems use silica gel or molecular sieve matrices for exchanging moisture and heat with air streams. Novel desiccant materials which absorb and desorb water at favorable temperatures and in substantial quantities could increase the ease of mass transfer, as well . Past research identified Type 1M materials as having preferred thermodynamic characteristics for a desiccant. Two approaches taken to develop this material, combining existing materials and creating a new chemical compound, yielded promising laboratory results but no commercially-available materials (Collier, 2000). Testing revealed potential flammability problems with the chemicals if used at higher regeneration temperatures characteristic of active desiccants (180-200°C).

Description of How Technology Saves Energy: Advanced desiccant materials with enhanced mass transfer characteristics could improve the efficiency of enthalpy wheels, decreasing the amount of energy required to cool or heat outdoor air. Applied to active desiccant systems, the materials would reduce the amount of energy required to regenerate the desiccant. Alternatively, they could achieve the same enthalpy exchange effect while reducing the ventilation energy penalty imposed by the enthalpy exchange device by decreasing its surface area and flow resistance

Technology Technical Maturity: Advanced.

Systems/Equipment Impacted by Technology: Dehumidification systems, enthalpy exchange devices.

Readily Retrofit into Existing Structures (no major structural modifications): Yes; would require installation of new wheel coated with advanced material.

Total Primary Energy Consumption by Systems/Equipment Impacted by Technology: 2.9 quads (upper bound, as system requires co-location of air intake and exhaust).

Performance Information/Data and Source: Collier (1997) posits that the Type 1M materials increase the desiccant wheel effectiveness, i.e., the percentage of the enthalpy gradient between the incoming and outgoing flow streams transferred between the two streams by the wheel, from ~75% to ~85%. Applying this increase to an enthalpy wheel installed in a New York City Office would increase the savings by about 15%, i.e., reducing unitary energy consumption by 41% (versus 35% for an enthalpy wheel using conventional materials).

Cost Information/Data and Source: Unclear, as the advanced desiccant materials have not been produced commercially. Internal TIAX research found that raw material expenses account for a small percentage of the cost of an enthalpy wheel system (on the order of 5 to 10%), suggesting that changes in the desiccant materials would not have a large impact upon the overall system cost. However, if the desiccant material achieved higher performance levels than conventional materials, it could realize appreciable reductions in

overall system cost by reducing the *size* of the device required for a given application. An enthalpy wheel manufacturer would likely use a high-performance desiccant material to achieve additional chiller plant reduction (via increased wheel efficiency) instead of reducing wheel size and cost (decreasing wheel surface area).

Non-Energy Benefits of Technology: In an enthalpy wheel, a gain in mass transfer effectiveness would augment the decrease in chiller capacity realized by enthalpy wheels. Alternatively, the increased effectiveness per surface area could be used to reduce the size (and cost) of the enthalpy wheel.

Notable Developers/Manufacturers of Technology: NREL performs work on advanced desiccant systems; Kirk Collier (2000) mentioned that he knows of no one actively carrying out research in the field at this time.

Peak Demand Reduction: YES, assuming that the desiccant material is used to increase the enthalpy exchange efficiency.

Most Promising Opportunities for Technology, Location(s) and Application(s): Buildings requiring large quantities of OA, located in humid climates.

Perceived Barriers to Market Adoption of Technology: Technology in R&D stage; no commercially-available chemicals with the appropriate characteristics. All of the barriers facing enthalpy exchange devices. Requires co-location of air intake and exhaust.

Technology “Next Steps”: Development of high-efficiency materials.

References:

Collier, R.K., 1997, "Desiccant Dehumidification and Cooling Systems: Assessment and Analysis", Final Report to Pacific Northwest National Laboratories, PNNL-11694, September.

Collier, R.K., 2000, Personal Communication, RNGTech.

Technology Option: Airfoil and Backward-Curved Centrifugal Blowers

Description of Technology: Many HVAC ventilation systems use vane- or tube-axial fans, while packaged units tend to employ centrifugal blowers outfitted with forward-curved (FC) fan blades. Alternatively, blowers can use a centrifugal blower with engineered airfoil-shaped or backward-curved (BC) blades. The airfoil-blade blower uses multiple (typically, 10-16) blades with airfoil contours curved away from the direction of rotation of the blower wheel. Similarly, a backward-curved centrifugal blower features multiple (10-16) blades of single-thickness which curve away from the direction of rotation. Due to their design, BI and airfoil blowers must turn much faster (about twice) than FC blowers to achieve the same volume flow but generate higher static pressures than FC blowers.

Description of How Technology Saves Energy: In centrifugal blowers, the aerodynamic characteristics of airfoil-blade blowers enable design for superior performance (i.e., efficient expansion of the air from the intake of the blower passages to the outflow) at the design pressure-capacity point. Although not quite as efficient as airfoil designs, the design of backward-curved blades also allow efficient expansion of the air as it passes through the blower. The improved drag-lift characteristics of the airfoil blower improves efficiency relative to standard blower designs. In all cases, improved blower efficiency translates into reduced blower power, as well as decreased cooling energy expended to cool blower energy (heat) dissipation during the cooling season.

Technology Technical Maturity: Current

Systems/Equipment Impacted by Technology: Potentially, all blowers.

Readily Retrofit into Existing Equipment and Buildings: Yes.

Total Primary Energy Consumption by Systems/Equipment Impacted by Technology: 1.2 quads (all exhaust fans and supply and return blowers).

Performance Information/Data and Source:

Summary: Airfoil, BC, and FC blowers chosen in the smallest blower size that can reasonably meet the application requirements (pressure drop and volume flow rate) have similar performance. Airfoil and BC blowers larger than the baseline size provide substantial efficiency gains over FC blowers [see “Larger Diameter Blowers and Fans” option for analysis of this option]. Airfoil and BC exhaust blowers have similar performance levels; FC blowers only appear in smaller exhaust blowers used for low pressure drop applications. In VSD applications, airfoil and BC blowers offer up to 20% efficiency improvements relative to FC blowers and also permit effective operation at much lower flow rates (and pressure drop) than FC blowers. Additional gains in blower static efficiency of up to 10% may be economically attainable.

TIAX Analysis: Performance data was obtained from a major blower vendor (Ludwig, 2001) for different blowers applied in air-handling unit (4,000cfm at a pressure drop of 750Pa) and unitary blower applications (15,000cfm at a pressure drop of 500Pa). Assuming that a designer would select the smallest blower size that can reasonably meet the application requirement, airfoil and BC blowers showed similar performance to FC blowers. Increasing the blower size above the baseline size leads to efficiency gains, particularly for airfoil blowers [see the “Larger Diameter Blowers and Fans” option for the energy savings potential]. Manufacturers’ literature⁷² indicates that most commercial exhaust blowers already have backward-inclined blades; smaller blowers do use forward-curved impellers. Comparisons between airfoil and BC blowers show similar performance when sized with the smallest blower size that can reasonably meet the application requirement. For a VSD application, airfoil and backward-curved blowers increased their efficiencies at lower pressure drop and cfm conditions by up to 20% (for a blower at the baseline size), whereas a blower with FC blades either does not increase in efficiency or could not operate at low enough flow rates⁷³.

Blier (1998): Airfoil and backward-curved performance degrades with dust-laden flows (adversely alters airfoil profile and lift-drag relationship).

ADL (2000): For a 10-ton unitary unit delivering 4,000cfm at 1.0” of water pressure drop, the efficiency and cost characteristics of an 18.5-inch BC plenum blower are similar to those of the 15-inch FC blower. Similarly, data comparing a 16-inch airfoil blower with a 15-inch FC blower show no appreciable difference in energy consumption between the two options wheel.

Cler et al. (1997): A veteran fan engineer sees 83% as the upper bound for practical fan efficiency, and imply that ~80% represents the economic upper bound. Further opportunities for fan efficiency gains include: tapered inlet cones for centrifugal blowers, better axial fan “root” or centrifugal blade-wheel aerodynamics, reduced tip clearances, better tolerances, airfoil shapes, airfoil shapes for support struts; in practice, poor inlet flows often compromise blower performance. They also cite a study that showed forward-curved blowers have inferior performance relative to backward-curved blowers at partial loads.

ADL (1999): Backward-inclined, particularly airfoil blades, perform better than forward-curved blades with VSDs because they exhibit superior stability characteristics at lower speeds.

Gustafson (2001): In many installation, system effects (ducting designs resulting in poor velocity profiles entering the blowers, elbows creating flow swirl counter to the direction of blower rotation, etc.) result in off-peak/design operation of blowers, with a significant (~10%) decrease in performance.

⁷² Comparing upblast exhausters: the ACME Engineering & Manufacturing Corporation airfoil-blade CentriMaster PNU with the Greenheck CVB series with BC blades.

⁷³ Assuming that system pressure drop varies as the square of the volume flow rate, the vendor data shows that the FC fan cannot operate effectively ~40% of maximum flow. For a linear pressure drop-volume flow rate relationship, fan effectiveness plummets ~60% of maximum flow.

TIAX: If the blower operates near the upper range of its pressure capability, a backward-inclined and airfoil blowers can more readily handle increases in pressure than forward-curved blower blades (the forward-curved blowers cannot operate at higher pressures).

Cost Information/Data and Source:

Summary: In air-handling unit and unitary blower applications, airfoil and BC blowers have price premiums on the order of \$500.

ADL (2000): In general, optimized blower/fan control offers more cost-effective energy improvements than changing the blower type. In a 10-ton unitary blower, a 16-inch airfoil blower wheel adds ~\$600 more to the price than a 15-inch FC blower wheel (both sized for a 4,000cfm, 250Pa pressure drop condition). This confirms the view of unitary A/C manufacturers that backward-curved blades as more economical than, and with similar performance to, airfoil blades.

TIAX Analysis: Price information obtained from a blower vendor (Ludwig, 2001) shows that a 15-inch airfoil blower assembly⁷⁴ for a unitary (4,000cfm/500Pa) application costs ~\$450 more than a FC blower. The BC blower (same size) has a similar price premium relative to the FC blower. For an air-handling unit (15,000cfm/750Pa) application, the airfoil and BC blowers both have a ~\$500 price premium relative to a FC blower.

Non-Energy Benefits of Technology: Less noise from more efficient blowers. Relative to FC blowers, airfoil and BC blowers resist stalling and overloading the motor (when the system pressure drop decreases), making them particularly well-suited for variable flow systems.

Notable Developers/Manufacturers of Technology: Numerous blower manufacturers.

Peak Demand Reduction?: No. Excepting “Larger Diameter Blowers and Fans”, for the application (see entry for that technology option), airfoil and BC blowers do not realize appreciable performance improvements at full-flow conditions needed to distribute “cooling” under peak conditions.

Most Promising Opportunities for Technology, Location(s) and Application(s): Variable-air-volume (VAV) units.

Perceived Barriers to Market Adoption of Technology: First cost, benefit for constant-volume operation appears to be negligible.

Technology “Next Steps”: Evaluation of potential design improvements for blowers.

⁷⁴ Including fan, OPD motor and drives; no accessories.

References:

ADL, 1999, "Opportunities for Energy Savings in the Residential and Commercial Sectors with High-Efficiency Electric Motors", Final Report for the U.S. Department of Energy, Office of Building Technology, State and Community Programs. Available at: http://www.eren.doe.gov/buildings/documents/pdfs/doemotor2_2_00.pdf.

ADL, 2000, "Energy Efficient Rooftop Air Conditioner: Continuation Application Technical Progress Statement", Presentation dated November 7, 2000 for the U.S. Department of Energy, Project #: DE-FC26-99FT40640.

ASHRAE, 1996, **ASHRAE 1996 Handbook: HVAC Systems and Equipment**, ASHRAE Press: Atlanta, GA.

Bleier, F.P., 1998, **Fan Handbook**, McGraw-Hill: New York, New York.

Cler, G. et al., 1997, **Commercial Space Cooling and Air Handling: Technology Atlas**. E Source, Inc.

Gustafson, T., 2001, "Is it the Fan or is it The System?", *AMCA International's Supplement to ASHRAE Journal*, November, pp. 21-25.

Jorgensen, R., 1990, "Fans and Blowers", appearing in **Handbook of HVAC Design**, McGraw-Hill: New York, New York.

Ludwig, R., 2001, Personal Communication of Loren-Cook Fan Performance and Cost Data, Alfieri Proctor Associates.

Technology Option: All-Water Thermal Distribution Systems

Description of Technology: The three main system types for distributing heating and cooling throughout a building that has a central or packaged HVAC plant are: all-air, all-water, or air-water. All-air systems, which serve a majority of commercial floorspace, distribute heating and cooling throughout a building via hot or cooled air. An air-water system distributes the heating/cooling from central sources (e.g., a chiller or boiler) to portions of the building via chilled water, from where it is transferred to the air in local ducts for distribution. In contrast, an air-water system heats and cools water at a central location, which flows through pipes to different part of the building. Ultimately, radiators and/or fan-coil units transfer the heat or cooling from the distribution water to areas within the building. Chapters 2,3 and 4 of ASHRAE (1996) discuss the different systems in more detail.

Description of How Technology Saves Energy: Due to the much lower density and heat capacity of air relative to water, all-air systems use significantly more energy to distribute heating and cooling than water systems to distribute the same quantity of thermal energy. Therefore, an air-water system that uses air distribution only to meet minimum fresh air requirements and uses a water-based system to meet any remaining thermal loads will use less energy than an all-air system.

Technology Technical Maturity: Current.

Systems/Equipment Impacted by Technology: Central HVAC pump/fan systems using all-air distribution.

Readily Retrofit into Existing Equipment and Buildings: No.

Total Primary Energy Consumption by Systems/Equipment Impacted by Technology: 1.1 quads (all parasitic energy for Central and Packaged systems, excluding FCUs).

Performance Information/Data and Source:

Summary: Air-water distribution systems would consume 0.35 quads less energy if they replaced the all-air systems in the U.S. (based on replacing packaged and central VAV and CAV systems with a fan-coil unit; detailed calculations of parasitic energy consumption by different types of systems, from ADL, 1999b).

Cost Information/Data and Source:

Summary: Air-water distribution systems (i.e., fan-coil units) have similar installed costs to all-air central distribution VAV systems, implying somewhat higher costs relative to a an all-air central CAV system. On the other hand, unitary equipment has a much lower installed cost than FCUs (based on TIAX Analysis).

Non-Energy Benefits of Technology: Water pipes and pumps use less building space than fans and ductwork (Modera et al., 1999). Air-water distribution systems offer greater occupant control over individual climate conditions resulting in higher comfort levels.

Notable Developers/Manufacturers of Technology: Fan-coil unit manufacturers; hydronic system/radiator manufacturers.

Peak Demand Reduction?: Yes.

Most Promising Opportunities for Technology, Location(s) and Application(s): Buildings with substantial cooling and heating loads with relatively low fresh air requirements (offices, retail, etc.).

Perceived Barriers to Market Adoption of Technology: Low first cost of packaged units relative to FCU architecture. Building designer survey of HVAC professionals (Modera et al., 1999) noted concerns about leaking, first cost, higher maintenance costs with water systems (in that order of concern). Also, the potential for water line leaks and subsequent water damage concerns installers (who catch the blame). Moisture and condensate removal by fan-coil units or radiant panels is perceived as a problem.

Technology “Next Steps”: Developed improved installed cost relative to other systems.

References:

ADL, 1999b, “Energy Consumption Characteristics of Commercial Building HVAC Systems Volume II: Thermal Distribution, Auxiliary Equipment, and Ventilation.” Final Report for the U.S. Department of Energy, Office of Building Technology, State and Community Programs. Available at:
<http://www.eren.doe.gov/buildings/documents/pdfs/comhvac.pdf> .

Modera, M., Xu, T., Feustel, H., Matson, N., Huizenga, C., Bauman, F., Arens, E., and Borgers, T. 1999. “Efficient Thermal Energy Distribution in Commercial Buildings.” Lawrence Berkley National Laboratory Report, LBNL-41365, August.

Feustel, H.E. 1994. “Hydronic Radiant Cooling Systems.” Center for Building Science News. Fall, 1994. page 4. Available at:
<http://eande.lbl.gov/CBS/NEWSLETTER/NL4/RadiantCooling.html> ; accessed February 25,2002.

ASHRAE, 1996, **ASHRAE Handbook: HVAC Systems and Equipment**, ASHRAE Press: Atlanta, Georgia.

Technology Option: Alternative Air Treatment

Description of Technology: At presently, most ventilation air is filtered by conventional (pleated or panel) filters to remove larger particles from the airflow. Alternative air treatment would cleanse the air to a greater degree to neutralize many bacteria and viruses, volatile organic compounds (VOCs, including formaldehyde) and cigarette smoke. In one variant, ultra-violet (UV) light in the “C” band (UVC) irradiates and kills bacteria and viruses. For instance, at least one commercial system⁷⁵ uses UVC lamps specially designed for the cold, HVAC environment that generate about six times the typical UVC output. In another manifestation, a UV lamp excites a photocatalytic surface, which neutralizes organic substances via chemical decomposition.

Description of How Technology Saves Energy: Per ASHRAE 62, a ventilation system must provide minimum quantities of outdoor air per building square foot or, alternatively, achieve certain minimum standards for indoor air quality. By neutralizing bacteria, VOCs, and smoke particulates, alternative air treatment could enable an HVAC system to achieve sufficient IAQ while requiring lower outdoor air volumes, reducing the air conditioning capacity to condition outside make-up air, simultaneously reducing supply and return and exhaust fan energy consumption, as well the energy needed to condition the OA. Some air treatment approaches, if applied to the evaporator coil, will reduce fouling of the coil, improving coil heat transfer and reducing cooling energy consumption.

Technology Technical Maturity: Current/New.

Systems/Equipment Impacted by Technology: Duct-based HVAC.

Readily Retrofit into Existing Equipment and Buildings: Yes.

Total Primary Energy Consumption by Systems/Equipment Impacted by Technology: 4.5 quads (all HVAC energy; however, it only impacts the OA portion of ventilation).

Performance Information/Data and Source:

Summary: Assuming that a UVC system is used to reduce outdoor air, a simple model based on binned weather and building load data reveals that reducing OA by 50% for a small office building⁷⁶ reduces HVAC energy consumption as shown in Table A-1. Clearly, different levels of OA decrease will result in different levels of savings, with large variations between building types and geographic regions. On the other hand, continuous use of UVC lights installed at a level sufficient to treat the peak ventilation requirement decreases the net primary energy consumption energy savings of the system by ~15% (for the 50% OA reduction case).

⁷⁵ Steril-Aire.

⁷⁶ Average of small offices in New York City and Fort Worth. Assumes that fan power varies proportional to the square of flow velocity.

Table A-1: Approximate HVAC Energy Consumption Impact of 50% Reduction in OA

Type of Load	Percentage Reduction	Cost Savings/Year
Ventilation (Supply and Return fans, Exhaust fan)	7%	\$0.01
Heating	27%	\$0.04
Cooling	14%	\$0.03

Claims of reductions in HVAC energy consumption from using air treatment to prevent coil fouling require laboratory assessment of performance degradation, combined with field data on degree and prevalence of fouling, to assess overall energy impact.

ACHRN (2000): A building operator estimated that UVC Light achieved a 28% reduction in HVAC system usage during cooling season by keeping the evaporator coil clean (thus reducing compressor work required). The UVC product company believes that 15-20% HVAC reduction in energy use is “typical”.

UniversalAir (2001): Photocatalytic system has a pressure drop of 0.13 inches of water at 1000cfm. System requires electricity usage for 8-15W UVC lights operated with a 1.25 ballast factor, consuming a total of ~150W for 1,000cfm. Includes ASHRAE 50% Phototech™ Pre-filter.

Cost Information/Data and Source:

Summary: TIAX Analysis – Assuming a first cost of \$0.30/cfm for a simple UVC system and annual operating costs of \$0.07/cfm for maintenance and \$0.02/cfm for UVC lamp operation and system fan power contribution⁷⁷, a 50% reduction in OA does not pay back because maintenance and light operation costs exceed operational savings (using the HVAC energy cost savings shown above in Table A-1).

ACHRN (2000): UVC bulb changeout recommended every year recommended, can be extended to 17 month in practice.

Bas (2000): Cost of installing UV system begins ~\$1,200, typically up to ~\$5,000 including add-ons.

Steril-Aire (2002): Typical cost of \$0.25-\$0.35/cfm, with an additional \$0.05-0.09/cfm for annual maintenance (lamps need replacing ~once per year).

Universal Air Technology (2001): A photocatalytic system costs ~\$1,400 for 1,000cfm duct system (not installed), with a system pressure drop ~0.13 inches of water⁷⁸.

Non-Energy Benefits of Technology: Improved IAQ and occupant health (sick-building syndrome), reduced liability risk from IAQ (e.g., legionella). Reduced evaporator coil and duct cleaning maintenance (ACHRN, 2000). If the air treatment system reduces OA

⁷⁷ Using 150W for 3,450 operating hours for lamps at \$0.07/kW-h; fan power cost for a 0.13 inches of water pressure drop at maximum volume flow rate is much smaller than lamp electricity, particularly for a VAV system.

⁷⁸ Data point selected by ADL; installed system pressure drop will vary depending upon system sizing.

required by 50%, calculations performed for the performance and cost analyses show that it could lead to a ~20% downsizing of the air-conditioning system. Blake (1995) authored a bibliography on processes for treating air or water.

Notable Developers/Manufacturers of Technology:

Solar “Photocatalytic Disinfection of Indoor Air “ research by Goswami (U. Florida), Photocatalytic device: being readied for the market by Universal Air Technology (now part of Lennox) at the Sid Martin Phototechnology Development Institute. Steril-Aire (UVC).

Peak Demand Reduction?: Yes. A decrease in OA requirements would produce the greatest absolute reduction in A/C load at peak demand conditions. For the coil cleaning argument, a clean coil will improve heat exchanger efficiency in all cases.

Most Promising Opportunities for Technology, Location(s) and Application(s):

Buildings with large cooling loads and large OA systems (e.g., hospitals).

Perceived Barriers to Market Adoption of Technology: At present, codes do not permit a decrease in ventilation rates below a required threshold per person. Even if the codes were changed to allow lower OA, any system that actively decreases OA below may assume full liability for any IAQ problems that arise, thus posing a very strong deterrent to this approach.

Technology “Next Steps”: Study of how to monitor the full spectrum of airborne pollutants and how lower OA impacts human health with and without alternative air treatment. Improved energy savings estimate for only keeping coils cleaned (distribution of coil cleanliness in actual HVAC systems and benefits from keeping clean).

References:

ACHRN, 2000, “UV Technology Sheds Light on IAQ Problems”, *ACHRNews*, 10 July, pp. 33-34.

Bas, E., 2000, “Contractor Puts UV Lighting System to the Test”, *ACHRNews*, 7 August, p. 33.

Blake, D., 1995, “Bibliography of Work on the Heterogeneous Photocatalytic Removal of Hazardous Compounds from Water and Air – Update Number 1, to June, 1995”, National Renewable Energy Laboratory, NREL/TP-473-20300, November. Available at: http://www.nrel.gov/chemistry_bioenergy/pdfs/update_1.pdf.

Steril-Aire, 2002, “About UVC – Frequently Asked Questions”, downloaded from: <http://www.steril-aire-usa.com/aboutuvc.htm> , on 26 March, 2002.

Universal Air Technology, 2001, “Sun-Central™ In-Duct Series”, Group A, Product Literature.

Technology Option: Apply Building Energy Software to Properly Size HVAC Equipment

Description of Technology: HVAC equipment, such as air-conditioners, is sized to meet peak thermal loads in a building (with heating equipment usually sized above peak capacity to enable quick “warm-up”). Until the widespread use of high-speed personal computing, complex heat transfer calculations made accurate calculations of actual building HVAC loads cumbersome for designers so they relied primarily on rule-of-thumb sizing estimates to select equipment capacities (based on floor area for example). With the development of personal computers, engineers developed software programs that solve the complex heat transfer equations to help designers more accurately size equipment. These software-based algorithms use weather data and inputs about the building design to predict the peak heating, cooling, and ventilation demands. Ranging from simple one-dimensional heat transfer models and binned weather data to complex three-dimension models using hourly weather data, the building energy models offer a wide range of accuracy and ease-of-use. Manufacturers such as Carrier (HAP™) and Trane (Trace™) distribute programs for equipment sizing (easier to use but less-accurate), while the U.S. Department of Energy has sponsored the development of algorithms (e.g., DOE-2 and Energy+) that are incorporated into commercial software such as VisualDOE and PowerDOE (more difficult to use but also more accurate). Several other, simpler sizing programs also exist (e.g., TRYNSYS, BLAST).

Description of How Technology Saves Energy: In many cases, over-sized HVAC equipment has poorer operational efficiency than properly sized equipment because it operates at lower part-load conditions and/or cycles on and off more often than necessary. In the case of over-sized blowers, they can consume more fan power than needed to meet OA and ventilation air requirements. If energy use models can reduce the occurrence and/or magnitude of equipment over-sizing then they will save energy. It is unclear whether energy use models compel building designers and engineers to reduce over-sizing, but it is likely that if designers have more confidence in energy models than other sizing strategies they may apply a lower factor of safety when sizing equipment.

Technology Technical Maturity: Current.

Systems/Equipment Impacted by Technology: All HVAC equipment and systems.

Readily Retrofit into Existing Equipment and Buildings: Not Applicable.

Total Primary Energy Consumption by Systems/Equipment Impacted by Technology: 3.8 Quads (based on an estimate that 85% of new buildings do not use energy models for sizing⁷⁹).

⁷⁹ This is likely high, as energy models are more likely to be used for larger buildings, i.e., 15% of buildings would represent a larger portion of total commercial floorspace and HVAC energy consumption.

RLW Analytics (1999): Over 25% of California-based building designers used energy model software to size equipment in ~60% of their new buildings, suggesting that ~15% of new buildings already use energy modeling to reduce equipment over-sizing.

Performance Information/Data and Source:

Summary: It is not clear how much energy savings are possible by correctly sizing HVAC equipment. Approximately 25-30% of rooftop air-conditioners are oversized by 25% or more, and possibly could have been more efficient had they been properly-sized by an energy modeling process. While the same percent (or more) of chillers are likely oversized, properly sizing them yields less energy savings in many cases because screw and centrifugal chillers are often staged and have good (relatively speaking) part-load efficiencies⁸⁰.

ASHRAE Handbook (1994): Safety factors of 10-20% are common when sizing HVAC equipment.

Santos et al. (2000): Contractors can dramatically over-estimate office equipment loads by using name plate wattage instead of actual, e.g., Komor (1997) found ~0.8W/ft² versus the 2-3W/ft² assumed by many designers.

Fryer (1997): The San Diego Gas & Electric Company metered chillers at 21 commercial buildings and found that in 2 cases the maximum load never exceeded 60% of the full rating of the chillers.

Wright et al. (2000)/ RLW Analytics (1999): Compared optimum cooling equipment size (as modeled by DOE-2) to actual equipment size in 667 new commercial buildings in California and found that 70% of the buildings had equipment sized within +/-30% of the optimum size.

Johnson (2001): Generally, sizing of cooling equipment on the west coast tends to be quite accurate for rooftop equipment; however, chillers are over-sized (but have better part-load efficiencies, so are not heavily affected).

CEE (2001): At least 25% of rooftop units are oversized by 25% or more; increases equipment costs and reducing efficiency by up to 50% (upper limit) via short-cycling and part-load operation.

Cost Information/Data and Source:

Summary: Running a complex (e.g., DOE-2) model costs \$0.10 to \$0.20/ft². Depending on the prevalence and degree of equipment over-sizing, energy models can yield an immediate

⁸⁰ On the other hand, over-sized chillers will tend to make more extensive use of hot gas bypass due to additional operating hours at low part-load levels, which increases chiller energy consumption.

payback through reduced equipment expenditures, particularly for cooling and ventilation systems.

Fryer (1997): A thorough DOE-2 simulation and building audit (including calibration with utility data) costs between \$0.10-\$0.20/ft². For a chiller retrofit, each extra ton of capacity costs \$800-1,000; in new construction, the cost more than doubles because ductwork and AHU equipment is also impacted.

TIAX Analysis: Based on Fryer (1997) DOE-2 and chiller costs, if each ton of cooling serves about 500ft², this implies a ~\$50 to \$100/ton cost for the simulations. For a retrofit case, assuming that most facilities incorporate a 15% oversizing (safety factor), running a DOE-2 simulation for *all* chiller retrofits should have immediate payback. Presumably, the cost per square foot of running a DOE-2 model will increase for smaller buildings.

Cler et al. (1997): “A thorough building audit, DOE-2 simulation, and calibration with utility billing may cost from \$0.06-\$0.30/ft².”

Hill et al. (2000): Retro-commissioning using DOE2.1 to size VSD gave immediate savings of \$0.18/sq.ft. because of down-sized equipment. The savings exceeded the cost of energy modeling.

Non-Energy Benefits of Technology: Proper sizing can decrease overheating and overcooling caused by cycling-induced temperature swings, improving occupant comfort and equipment reliability and longevity. Oversized air-conditioning equipment can provide poor humidity control. Reduces surge in chillers.

Notable Developers/Manufacturers of Technology: Comprehensive list of software tools is available at: www.eren.doe.gov/buildings/tools_directory/. Most popular models are developed by Carrier (HAP), Trane (Trace), the DOE (DOE-2 and Energy+), Texas A&M University (EnerWin), and Wrightsoft (Right-Suite).

Peak Demand Reduction?: Maybe. Depends on the compressor part-load curves and by how much the units are oversized. Moderately oversized systems should result in peak demand reductions, as they will have more heat transfer area available than a properly-sized system *if* compressor capacity is modulated. It will save energy for unitary A/C and ventilation, which tends to have less capacity modulation capability

Most Promising Opportunities for Technology, Location(s) and Application(s):

New construction (allows accurate sizing of all systems) in buildings with large HVAC loads (more equipment expenditure/ft²), for equipment with pronounced cycling losses (air-conditioners, furnaces) and pronounced part-load inefficiencies (air-conditioning equipment with reciprocating and scroll compressors – unitary equipment).

Perceived Barriers to Market Adoption of Technology: First cost. Mistrust of modeling results by designers and contractors (large room for user input errors). Liability of under-

sized equipment falls on the contractor or designer, so it is safer for them to use large factors of safety when sizing (rather than risk complaints from building occupants and responsibility for fixing problems) even if they have an accurate energy model.

Technology “Next Steps”: Better communication between architects and HVAC system designers. Development of user-friendly tools to decrease cost of performing analyses. Education of building owner of cost benefits of properly sizing equipment. Investigation to develop more information on the degree (amount and prevalence) of over-sizing of cooling and ventilation equipment and potential energy benefits.

References:

ASHRAE, 1994, **ASHRAE Handbook: Refrigeration**. American Society of Heating, Refrigerating, and Air-Conditioning Engineers, Inc., Atlanta, GA.

CEE, 2001, “Guidelines for Energy-Efficient Commercial Unitary HVAC Systems”, Final Report for the Consortium for Energy Efficiency, 19 January.

Cler, G. et al., 1997, **Commercial Space Cooling and Air Handling: Technology Atlas**, E Source, Inc.

Fryer, L., 1997, “Electric Chiller Buyer’s Guide: Water-Cooled Centrifugal and Rotary Screw Chillers”, *E-Source Tech Update*, TU-97-7.

Hill, R. Kessler, H., and Lannon, J., 2000, “Increasing Real Estate Value Through Retro-Commissioning”, *Proceedings of the National Conference on Building Commissioning*, May 3-5, Kansas City, MO.

Johnson, Jeff, 2001, Personal Communication, New Buildings Institute.

RLW Analytics, 1999, “Final Report: Non-Residential New Construction Baseline Study”, **California State-Level Market Assessment and Evaluation Study**, 8 July.

Santos, J.J., Brightbill, E.L., and Lister, L., 2000, “Automated Diagnostics from DDC Data – PACRAT”, *Proceedings of the National Conference on Building Commissioning*, May 3-5, Kansas City, MO.

Wright, R., Brown, M., Mahone, D., Peet, R., and Jacobs, P., 2000, “The California Statewide Baseline Study of the Nonresidential New Construction Market”, *Proceedings of the American Council for an Energy-Efficient Economy (ACEEE) 2000 Summer Study on Energy Efficiency in Buildings*, August, Ocean Grove, CA.

Technology Option: Building Automation Systems/Building Energy Management Systems

Description of Technology: Building Automation Systems (BAS) are control systems that centralize and automate the control of various building systems such as HVAC and lighting. Sometimes referred to as Building Energy Management Systems (BEMS), BAS links all the systems in a building together for smart monitoring, control, and diagnostics to make it run more effectively. The fundamental pieces of a BAS system are sensors, controllers, actuators, and computer workstations (or Internet website) integrated via specialized software. The sensors provide inputs to the controllers such as temperature, humidity, occupancy, or CO₂ levels. The controllers interpret the inputs and, using control algorithm software, determine a response signal to send to the system components to produce the desired system changes such as closing dampers, opening valves, or turning off a chiller. One vision of future BAS systems is to have fully integrated fire, security, lighting, HVAC, and other systems all controlled through one control network.

Description of How Technology Saves Energy: BAS save energy by “intelligently” operating building systems using techniques such as scheduling, occupancy-based operation by zone, night set-back, economizing, optimum start and stop, nighttime ventilation, equipment lockouts, and chiller/boiler setpoint changes. HVAC system energy savings represent only a portion of the energy saved, as BAS systems also can reduce lighting and other equipment energy consumption. Ideally, BAS would integrate all the equipment in a building, giving it a unique ability to optimize energy consumption (though this goal has not yet been realized) throughout the building, something a conventional HVAC control system can not do. BAS also enables large building owners (of an office building for example) to bill their tenants on an individual basis for energy used (rather than on a per square foot basis) giving tenants incentive to save energy where before they had none.

Technology Technical Maturity: Current/New.

Systems/Equipment Impacted by Technology: All HVAC systems and equipment.

Readily Retrofit into Existing Equipment and Buildings: Yes, although in some instances wiring can pose problems; future development and deployment of sensors that exploit wireless communication would address that issue.

Total Primary Energy Consumption by Systems/Equipment Impacted by Technology: 4.4 (all HVAC equipment except “individual” units).

Performance Information/Data and Source:

Summary: While it is not entirely clear how much HVAC energy is saved by a BAS system, whole building savings range between 5% and 10%. While many large commercial

buildings already have a BAS system of some kind, a large portion may not be realizing much of the potential energy savings.

ADL (1997): Pre-installation energy saving estimates typically range from 5% to 15%, but actual savings tend to be lower because of human factors (manual over-rides, optimizing comfort rather than energy savings, and poor maintenance for example). Used 5% energy savings as a realistic estimate of actual building energy savings.

L. Campoy (2000): 15% overall annual energy savings is possible for restaurants using BAS to control HVAC, lighting, refrigeration, and foodservices equipment.

ASHRAE Journal (1998): A BAS installed in a 12,750ft² office building reduced the gas consumed for heating by ~26%.

E-Source (1998): Nearly one-third of all buildings over 100,000ft² have a BAS/EMS system. A study of 11 buildings in New England with BAS systems showed that 5 achieved substantially sub-par energy savings (~55% of expected) with one showing no savings, because the systems were not implemented as intended and were performing tasks that traditional control system already did (Wortman et al. 1996). BAS systems are capable of saving, on average, 10% of the overall annual energy consumed by buildings.

Cost Information/Data and Source:

Summary: BAS systems cost between \$1 and \$4 per square foot, and give a simple payback period of ~8-10 years.

E-Source (1998): BAS systems can cost between \$400 and \$2,000 per monitoring or control point. In case studies office buildings have seen installed costs of \$500-\$1000 per point, or \$2-\$4 per square foot of floor area. Gives an ~8-10 year payback.

ADL (1997): Estimates that a basic system with front-end DDC system for HVAC and lighting costs ~\$1.50 per square foot. Systems typically have about 10-year payback period based on energy savings.

Piette et al. (2000): Cost of a BAS system is ~\$1 per square foot.

Ivanovich (2001): Anecdotal evidence that BEMs “are finding 2-to-5% billing errors from utilities” and that the corrections more than pay for the BEM and its infrastructure.

Non-Energy Benefits of Technology: Improved comfort by reducing over-heating and over-cooling of spaces, and by offering customizable zone control. Saves money by reducing labor required for operating the building (by cutting the number of man hours required to control the systems). May uncover energy billing discrepancies. Building security monitoring.

Notable Developers/Manufacturers of Technology: Numerous. NIST (Cybernetic Buildings Program), Siemens, Honeywell, Johnson Controls, Facility Dynamics, Trane (TRACE).

Peak Demand Reduction?: Yes. A BAS allows a building operator to monitor a building's energy consumption and reduce electric loads at peak demand times to reduce demand and demand charges. Peak electrical demand can be controlled by sequencing fans and pumps to start up one by one rather than all at once and by shutting off pieces of HVAC equipment for short periods (up to 3 minutes), which should only minimally affect space temperature.

Most Promising Opportunities for Technology, Location(s) and Application(s): Larger buildings with large heating and cooling loads and ventilation requirements.

Perceived Barriers to Market Adoption of Technology: First cost; Poor past performance; Fear that complaints may increase when building operation is largely automated; Inability or unwillingness to support BAS with service contracts; Ignorance of savings magnitude; General unfamiliarity of controls; Fear of job losses associated with displacement by technology.

Technology “Next Steps”: More refined breakdowns of energy savings for installed systems (e.g., HVAC, lighting, etc.). Potential energy and cost savings of future BAS “visions” – fully automated systems. Cost reduction efforts. Training for building operators. Facilitate integration of continuous commissioning and diagnostics tasks.

References:

ADL, 1997, “Massachusetts Market Transformation Scoping Study: Stage II Final Report”, Arthur D. Little, Inc. for the Massachusetts Gas DSM/Market Transformation Collaborative, September.

Campoy, L., 2000, “Energy Management System”, **Southern California Edison Emerging Technologies Database**, 4 October, p.11. Available at: <http://www.ca-etcc.com/Database/ETdatabase.pdf> .

David N. Wortman, Evan A. Evans, Fred Porter, and Ann M. Hatcher, 1996, “An Innovative Approach to Impact Evaluation of Energy Management System Incentive Programs”, *Proceedings, American Council for an Energy Efficient Economy Summer Study*, August, pp.6.163–171.

E-Source, Inc., 1998, “Design Brief: Energy Management Systems”, Energy Design Resources, Southern California Edison; last accessed March 2002 at: http://www.energydesignresources.com/publications/design_briefs/pdfs/enrgyman.pdf .

Piette, M.A., Khalsa, S. and Haves, P., 2000, "Use of an Information Monitoring and Diagnostic System for Commissioning and Ongoing Operations", *Proceedings of the National Conference on Building Commissioning*, May 3-5, Kansas City, MO.

Technology Option: Chemical Exothermic/Endothermic Heat/Cool Generation

Description of Technology: Conceptually, a chemical exothermic/endothermic system would use a chemical reaction(s) to locally generate (for heating) or absorb heat (for cooling). In either case, chemicals are isolated from each other until a demand for heating or cooling exists. When heating or cooling is needed, the chemical compounds react to either give off or absorb heat. . In practice, the compounds could be brought together in a vessel and the heating or cooling distributed throughout the building via conventional mechanisms (i.e., air or water distribution). Cold packs activated by the crushing of a plastic bag containing two (before crushing) isolated compounds represent a commercialized example of the technology concept. Absorption cooling represents the cyclical analog to this batch process.

Description of How Technology Saves Energy:

If the energy required to create, transport, and dispose of the chemical compounds used in the reactions is less than the energy consumed by conventional equipment (e.g., a furnace to heat and a chiller to cool a building), then this approach would result in a net energy savings.

Technology Technical Maturity: Advanced.

Systems/Equipment Impacted by Technology: All heating and cooling systems.

Readily Retrofit into Existing Equipment and Buildings: No.

Total Primary Energy Consumption by Systems/Equipment Impacted by Technology: 3.2 quads.

Performance Information/Data and Source: None.

Cost Information/Data and Source:

Summary: In all likelihood, this approach costs significantly more than conventional heating or cooling approaches. An analysis performed with very optimistic assumptions for the transport of ice from cold to warm regions shows that one year of cooling via ice transport exceeds the cost of installing a chiller and the cost of electricity for that year. Although other materials may have a higher energy density (based on chemical potentials), most would cost substantially more than (essentially free) ice, and may pose disposal issues.

TIAX Analysis: An appropriate combination of materials to provide the exothermic/endothermic reaction could not be developed. Clearly, however, salts used in cold packs” would cost too much and provide very large disposal barriers. Similarly, the

transport of aluminum filings (to react with air) or sodium (to react with water) to generate heat⁸¹ would also suffer from very large cost barriers.

To provide a rough idea of the lower-bound on cost for cooling, the transport of ice from colder regions to warmer regions was studied, as it has negligible material costs and minimal disposal problems. In an optimistic scenario, assuming that ice harvesting incurs no labor costs, the ice costs \$0.02/ton/mile to transport⁸² and that the ice travels 1,500 miles from source to end use, complete use of the cooling value of the ice (below 50°F) has a cost of ~\$1.10 per ton-hour of cooling delivered. In contrast, a chiller that consumes 1 kW/ton located in a region where electricity costs \$0.25/kW-hour produces cooling at only \$0.25/ton-hour. Assuming that the ice transport scheme eliminates a chiller costing \$600/ton and that this cost is amortized over a year (with 800 equivalent full-load hours of operation), the chiller still generates cooling less expensively than the ice transport system.

Non-Energy Benefits of Technology:

First cost reduction for cooling equipment, as reactants replace need for chiller.

Notable Developers/Manufacturers of Technology: None known.

Peak Demand Reduction?: Yes. It would supplant chiller operation during cooling periods (parasitic energy required to distribute cooling remains).

Most Promising Opportunities for Technology, Location(s) and Application(s):

Buildings with large cooling loads located near a source of the reactants.

Perceived Barriers to Market Adoption of Technology: Cost. Potentially: Transport and storage of reactants, disposal of reaction products.

Technology “Next Steps”: Pre-R&D conceptual analysis.

References:

Bing, A., 2002, Personal Communication, Arthur D. Little, Inc.

⁸¹ Actually, a most-workable set of materials with an exothermic reaction dominates the heating market: hydrocarbons.

⁸² According to Bing (2002), a value on the low-end of transport costs for large quantity transport for commodities such as coal.

Technology Option: Complete (New Building) and Retro-Commissioning

Description of Technology: Complete commissioning involves thoroughly checking out the building HVAC systems to ensure that all equipment, sensors and systems operate properly and as intended (designed). It also involves tuning the system and its controls to achieve expected equipment and system performance, and providing proper training to building operators and maintenance personnel to facilitate sustained high performance. In addition, commissioning should include documentation of system design, operational procedures and maintenance requirements. To ensure proper building function under a wide range of conditions, ideally the commissioning process should begin during the project design phase and extend well beyond the completion of construction. Retro commissioning denotes performing the commissioning process for an existing building to establish that the existing HVAC systems, equipment, sensors and systems operate properly and as intended.

A related area, continuous commissioning, strives to continuously monitor equipment and system performance to evaluate building performance in close-to real time. As such, it overlaps with building diagnostics, for which Claridge et al. (1999) identify two primary approaches: time series data (automated or manual examination of building operational data to determine if the correct schedules are followed) and Models and Data (comparison of actual building energy consumption to modeled performance). To support this process, he and his group have developed “signatures” for expected performance of several building AHU configurations, which are compared to actual performance to perform diagnosis of many common building operational faults: VAV operating as CAV, simultaneous heating and cooling, excess OA, sub-optimal cold/hot deck schedule, etc.

Description of How Technology Saves Energy: By ensuring proper operation and tuning equipment and systems, as well as allowing prompt fixing of problems that arise, complete commissioning can significantly reduce unneeded heating, cooling and ventilation, and, via maintenance, improve sustained efficient building operation.

Technology Technical Maturity: Current, although not widespread. Commissioning most common in public sector (RLW Analytics, 1999), but it is estimated that less than 5% of new buildings and less than 1% of existing buildings, are commissioned (Engineered Systems, 1999).

Systems/Equipment Impacted by Technology: All HVAC systems.

Readily Retrofit into Existing Equipment and Buildings: Complete commissioning is germane only to new construction or major renovations, while continuous and retro-commissioning apply existing structures

Total Primary Energy Consumption by Systems/Equipment Impacted by Technology: 4.7 quads.

Performance Information/Data and Source:

Summary: On average, commissioning reduces building HVAC energy consumption by ~10%, with larger savings possible for older buildings.

Fault problems in buildings, reported in Piette et al. (2000) from other sources:

- Hagler Bailly Consulting (1998): new construction commissioning survey found that 81% of building owners had problems with new HVAC systems
- Piette et al., 1994 (60 buildings): half of buildings had controls problems, 40% had HVAC equipment problems, 15% had missing equipment, 25% had BEMS, economizers, and/or VSDs with improper functioning.
- Claridge et al. (1998): Continuous commissioning saved an average of >20% of total energy cost, >30% of heat/cooling cost in 80-building study.

Piette et al. (2000): Most BEMS do not include energy monitoring in their scope; many that do need much more user-friendly features to enable user to analyze data.

Piette (2001): BEMS often not optimized for each building, needs to be done via commissioning.

Energy Design Resources (2001a): Cited studies for Montgomery County (MD) facilities division where commissioning saved an estimate \$1.57/ft² in up-front change orders and claims, and \$0.48/ft² in first-year energy savings.

Claridge et al. (1999). Retro-commissioning/whole building diagnostics identified potential annual savings ~11.5%, with 69% of the savings occurring in HVAC (8 buildings, in Texas).

Hewett et al. (2000): Cites Gregerson (1997) study (44 buildings) finding of 19% average energy savings finding with simple paybacks almost always less than 2.5 years.

CEE (2001): cites study showing 8 to 20% less annual operating cost than un-commissioned buildings.

Cost Information/Data and Source:

Summary: On average, commissioning of existing buildings costs ~\$0.20 to \$0.30/ft², with very large variations between buildings, which translates into payback periods on the order of 2 years. For new buildings, commissioning costs ~2 to 4% of initial HVAC equipment costs.

Nadel et al. (1998): Citing Gregerson (1997) as source for \$0.03-\$0.43/ft² cost to commission existing buildings, often with 5-15% energy savings and <2 years payback.

CEE (2001): Cites study showing that commissioning costs 2 to 5% of the cost of the commissioned equipment.

Energy Design Resources (2001a): Cited PECE estimate of commissioning costs \$0.30-\$0.90/ft².

Pierson (2001): For involvement of commissioning professional from beginning to end of construction, “rule of thumb” of 2 to 4% of commissioned systems’ cost; cites simple paybacks for several buildings of 0.2 to 1.9 years. Data for Canada estimates commissioning to cost 1-3% of HVAC construction costs; for buildings with BEMS and in excess of 12,000ft², costs ranged from \$0.02-\$0.64/ft², with an average of \$0.21/ft².

Claridge et al. (1999): Their commissioning work since 1993 in more than 100 buildings shows commissioning costs ranging from \$0.024-\$2.00/ft² (assuming \$100/hour for labor), with an average of \$0.36/ft² (offices ~\$0.33/ft² for a savings of \$0.22/ft²/annum). They further note that advanced BEMS tend to significantly reduce commissioning costs relative to building without or with older EMCS buildings.

McQuillen (1998): Portland Energy Conservation Inc. found an average price of \$0.19/ft² for commissioning activities (175 building case studies).

Non-Energy Benefits of Technology: Improved occupant comfort from better climate control (potentially improving productivity), reduced maintenance (~20%, or ~\$0.15-\$0.20/ft² in one case study by Piette et al, 2000) and complaints. Claridge et al. (1999) mention finding billing errors, identifying leaks which can lead to structural damage. Complete commissioning usually improves owner/occupant satisfaction with building (by dramatically reducing problems upon occupancy).

Notable Developers/Manufacturers of Technology:

Research and Commissioning Software Products: Texas A&M (Claridge); some utilities promote (e.g., PG&E, NW Alliance); Portland Energy Conservation, Inc; Facility Dynamics.

Organizations Supporting Commissioning: *National Environmental Balancing Bureau* (NEEB) – developed a “Building Systems Commissioning Standards” manual. *ASHRAE* issued Guideline 1-1996, “The Commissioning Process” (see also: *ASHRAE* (1999), “Building Commissioning”, Chapter 41; *ASHRAE* Technical Committee, TC9.9: Building Commissioning). National Institute of Building Sciences (NIBS) - “Guidelines for Total Building Commissioning”. Building Commissioning Association (BCA) authored a Building Commissioning Attributes document, to guide commissioning projects and provide training via professional development courses.

Peak Demand Reduction?: Likely – assuming that commissioning improves system performance during peak demand periods.

Most Promising Opportunities for Technology, Location(s) and Application(s): Older buildings/systems with deferred maintenance; buildings with high HVAC energy consumption.

Perceived Barriers to Market Adoption of Technology: First cost; lack of awareness with building owner/operators of what is commissioning; lack of qualified personnel to commission buildings; split incentives (building occupants pay bills but do not own system). Implementation of energy saving measures sometimes difficult because operators may place a very high value on not receiving complaints from occupants and do not want make changes in building operations (Claridge, 1999). RLW Analytics (1999) notes that “most clients feel that testing and balancing of systems by the responsible contractor is sufficient and opt not to follow their advice for complete, independent commissioning,”

Technology “Next Steps”: Owner/operator awareness of commissioning benefits; contractor awareness/training; develop standard for minimum work for commissioning, certification for commissioning professionals. Incorporate cost of commissioning into cost of building renovation/construction mortgage, allowing the energy savings to cover the cost of the additional financing (interest). Incentives for commissioning, e.g., New Jersey’s Energy Efficient Commercial & Industrial Construction Program offers building commissioning: “Building Commissioning is free of charge for larger comprehensive or custom projects where both the customer and the program’s investments are substantial and worthy of additional startup attention.”⁸³

References:

ASHRAE, 1999, **ASHRAE Handbook, 1999: HVAC Applications**, American Society of Heating, Refrigerating and Air-Conditioning Engineers, Inc., Atlanta, GA.

CEE, 2001, “Guidelines for Energy-Efficient Commercial Unitary HVAC Systems”, Final Report prepared for the Consortium for Energy Efficiency, 19 January.

Claridge, D., Liu, M., Turner, W.D., 1999, "Whole Building Diagnostics", *Proceedings of Workshop on Diagnostics for Commercial Buildings: from Research to Practice*, June 16-17, 1999, Pacific Energy Center, San Francisco, available at: <http://poet.lbl.gov/diagworkshop/proceedings/>.

Energy Design Resources, 2001a, “Design Brief: Building Commissioning”, last accessed February, 2001, at: http://www.energydesignresources.com/publications/design_briefs/pdfs/commiss.pdf.

Engineered Systems, 1999, “Issues & Events – In Efficiency (and Market Forces) We Trust”, *Engineered Systems*, July, p.26.

⁸³ http://www.njcleanenergy.com/html/comm_industrial/comm_ind_const.html

Hewett, M.J., Hancock, M.W. and Szydlowski, R.F., 2000, “Competitive Buildings Initiative Brings Retrocommissioning to Minnesota”, *Proceedings of the National Conference on Building Commissioning*, May 3-5, Kansas City, MO.

McQuillen, D., 1998, “3 Case Studies for Improved IAQ”, *Environmental Design and Construction*, May/June. Available at:
http://www.edcmag.com/CDA/ArticleInformation/features/BNP_Features_Item/0,4120,19193,00.html .

Piette, M.A., 2001, Personal Communication, Lawrence Berkeley National Laboratory.

Piette, M.A., Khalsa, S. and Haves, P., 2000, “Use of an Information Monitoring and Diagnostic System for Commissioning and Ongoing Operations”, *Proceedings of the National Conference on Building Commissioning*, May 3-5, Kansas City, MO.

RLW Analytics, 1999, “Final Report: Non-Residential New Construction Baseline Study”, California State-Level Market Assessment and Evaluation Study, 8 July.

Santos, J.J., Brightbill, E.L., and Lister, L., 2000, “Automated Diagnostics from DDC Data – PACRAT”, *Proceedings of the National Conference on Building Commissioning*, May 3-5, Kansas City, MO

Technology Option: Copper Rotor Motors

Description of Technology: Most induction motors presently use squirrel cage rotors with aluminum conductor bars, owing to the high electrical conductivity of aluminum and its relative ease of mass production via die casting (Cowie et al., 2001). Copper rotor motors replace the aluminum motor rotor used in almost all induction motors with copper conductor bars in the rotor.

Description of How Technology Saves Energy: The efficiency of induction motors is limited by the amount of active material in the core, rotor and windings. Materials with superior electromagnetic qualities (such as copper, with approximately twice the electrical conductivity of aluminum) decrease the motor losses, improving the overall efficiency of the motor.

Technology Technical Maturity: New. Copper rotor motors find use in niche applications, where very high energy consumption (and savings opportunity) supports the economics of constructing a copper rotor motor (Cowie, 2000a). For example, Westinghouse uses a copper rotor in all motors over 250HP.

Systems/Equipment Impacted by Technology: All HVAC system motors, particularly those 1HP or larger.

Readily Retrofit into Existing Equipment and Buildings: Yes.

Total Primary Energy Consumption by Systems/Equipment Impacted by Technology: 2.9 quads; ~2.3 quads for motors 1HP or larger (mostly exhaust fans eliminated). Much larger savings outside of commercial HVAC sector, i.e., for industrial motors.

Performance Information/Data and Source:

Summary: Preliminary tests support motor models that show that copper rotor motors can realize at least a 1% improvement over current aluminum motors. As with many energy efficiency technologies, manufacturers will likely seek to achieve a balance between efficiency gains and cost reduction.

Cowie (2000a): Believed that re-design efforts (if put solely into improving efficiency) for a 10HP motor could achieve 92.5% efficiency. This is higher than currently available premium motors. Currently, the premium efficiency of a 10 hp motor is at 91%, compared to EPACT level of 89.5% (ASHRAE Standard 90.1-1999).

Cowie et al. (2001): Full load losses ~40% less than with aluminum rotors; this result varied little between rotors made under different conditions. As a result, motor efficiency improved by between 1.2 and 1.6% in 15HP motors (~35% more copper used in the motor with 1.6% efficiency gain).

Cost Information/Data and Source:

Summary: Presently, copper rotor motors are not cost-competitive in HVAC applications. The success of ongoing research by the Copper Development Association (CDA) to extend the life of dies used to make the copper rotors into the thousands of shots per die range will determine whether or not copper rotors will effectively compete with current aluminum rotor motors. As with many energy efficiency technologies, manufacturers will likely seek to achieve a balance between efficiency gains and cost reduction.

Cowie (2000a): Presently, copper rotor motors cannot compete with aluminum rotor induction motors due to the impracticality of mass-producing the rotors. Specifically, they cannot be die cast because the die does not wear well due to the high melting temperature of copper (relative to aluminum). The CDA projects that if the die design program succeeds (i.e., per Cowie et al. [2001], achieves a die lifetime of several thousand shots), a copper rotor motor re-design focused upon cost could realize a *manufacturing cost* of ~\$204/10HP motor (91% efficiency), versus \$240 for premium 10HP motor.

Cowie (2000b): The economics of a copper rotor motor reflects a balance between the yield of the die (units/die before die failure) and motor cost (size). Consequently, copper rotor technology appears favorable for motors 1HP or larger.

Copper Development Association (2002): Substituting copper for aluminum in a 15hp motor has a ~\$10 cost premium for the materials (\$14 versus \$4). Amortizing the cost of the die insert over a lifetime of 20,000 shots adds ~\$0.65, and the electricity used to melt the copper adds an additional ~\$0.65. In total, the cost premium equals ~1% of the motor *list price*.

Non-Energy Benefits of Technology: Could reduce motor weight (by 5-10%, if focused upon reducing weight; Cowie, 2000a). Lower operating temperatures tend to decrease insulation wear, improving motor lifetime. The improved motor efficiency reduces the waste heat produced by the motor, decreasing cooling loads.

Notable Developers/Manufacturers of Technology: Copper Development Association organized a consortium including: ThermoTrex (die manufacture/development), Formcast (die development), Baldor Motors, Buhler North America (casting process), THT Presses (die casting); Funding from DOE (Office of Industrial Technologies) and Air-Conditioning Research Institute (ARI).

Peak Demand Reduction: YES. The benefit of copper rotors will be the greatest at full power operating conditions; the higher efficiency will reduce the waste heat generated by the motor.

Most Promising Opportunities for Technology, Location(s) and Application(s): All HVAC motors operating with high duty cycles and high loads.

Perceived Barriers to Market Adoption of Technology:

Nadel et al. (1998): Copper is costs more and has manufacturing problems. A single die can only cast a small number of rotors, and as these dies cost \$100,000's each, this facet of production makes production uneconomic.

Cowie et al. (2001): Inconel alloys 617, and 625 operated at high temperatures (600 to 650°C) are very promising mold materials for die casting of copper rotor motors. Test runs of 950 shots demonstrated the importance of elevated mold temperatures (at all times) to minimize damage from thermal cycling; however, the tested lifetimes still fall short of the “thousands of casting cycles” cited for economic feasibility. Recent testing also demonstrated the robustness of the processes under development, as copper rotors cast under a wide variety of conditions performed similarly in motors and exhibited similar physical qualities.

Technology “Next Steps”: Continued development of dies with acceptable lifetimes to cast rotors, with a follow-on push for field testing. Voluntary market promotion program for motors.

References:

Cowie, J.G., 2000a, “Application of High Temperature Mold Materials to Die Cast the Copper Motor Rotor”, White Paper offered by the Copper Development Association, available at: <http://innovations.copper.org/global/motorrotor.html> .

Cowie, J.G., 2000b, Personal Communication, Copper Development Association.

Cowie, J.G., Brush, E.F., Peters, D.T., and Midson, S.P., 2001, “Materials & Modifications to Die Cast the Copper Conductors of the Induction Motor Rotor”, *Die Casting Engineer*, September, pp. 38-45. Available at: <http://www.copper-motor-rotor.org/pdf/nadca.pdf> .

Copper Development Association. 2002. “The Numbers Are In: Important Financial Data Revealed”. *Update: Copper Rotor Motor*, vol.2, issue 3.

Nadel, S., Rainer, L., Shepard, M., Suozzo, M., and Thorne, J, 1998, “Emerging Energy-Saving Technologies and Practices for the Building Sector”, American Council for an Energy-Efficient Economy (ACEEE) Publication, December.

Technology Options: DDC Finite State Machine Control Algorithms

Description of Technology: Air-handling units (AHU) provide heating, cooling, and ventilation to a building and often use outdoor air for cooling (instead of mechanical cooling) when outdoor air is not too hot or humid (called economizer operation). The control of such a system is complex because the AHU must choose the optimum operation of four distinct operating states (heating, economizing, economizing+cooling, and cooling) based on inputs of temperature, humidity, and airflow measurements. As such, some traditional AHU control systems are tuned to exhibit very slow system response to avoid control instabilities, such as oscillation between heating and economizing. A finite state machine (FSM) control system uses different control algorithms for each of the four operating states of an AHU, enabling more aggressive tuning within each operating state (faster response to changing conditions) while limiting the response time to prevent oscillation between the operating states. While traditional AHU control systems use a single proportional plus integral (PI) controller, FSM control systems use three separate PI controllers (one each for the heating coil, cooling coil, and dampers), but all other control system equipment can be the same.

Description of How Technology Saves Energy: On its own, a properly tuned FSM control system will not necessarily save energy versus a properly tuned traditional (single PI controller) system. A poorly-tuned traditional control systems for AHUs may oscillate between two operating states and waste energy as it alternates between states, e.g., heating and cooling. By applying a long time constant to minimize changes between states while using appropriate control algorithms for different states, the FSM control system avoids oscillation between operating states and reduces cycling losses. FSM algorithms only have a significant impact under conditions near the boundaries of different operational regimes.

Technology Technical Maturity: New.

Systems/Equipment Impacted by Technology: Air handling units (AHUs) with heating coils, cooling coils, and economizers (central and packaged).

Readily Retrofit into Existing Equipment and Buildings: Yes.

Total Primary Energy Consumption by Systems/Equipment Impacted by Technology: 2.6 Quads. (Value includes [but should not] non-AHU central heating systems, AHU systems with either heating-only or cooling-only operation, and AHU systems without economizers).

ADL (2001): Energy consumed annually by central and packaged cooling systems and all heating equipment except unit heaters and space heaters is 2.6 Quads.

Performance Information/Data and Source:

Summary: The actual prevalence of mis-tuning is not known, as is the distribution (percentage of systems mis-tuned to different degrees) of mis-tuning, making assessment of the actual energy savings very difficult. For very poorly and aggressively tuned (e.g., at least 5-fold too high gain setting) control systems, FSM system may potentially approach ~30% annual savings in heating energy consumption and ~13% annual savings in cooling energy.

Seem et al. (1999): “The two strategies were found to perform nearly the same under most conditions. However, when the PI controller was tuned too aggressively, the FSM control strategy yielded a 31% reduction in heating coil energy, a 13% reduction in cooling coil energy, improved temperature control, and reduced actuator use” Annual energy savings only occurred in any measurable fashion when the traditional control system was tuned for “very aggressive” control; at other gain settings, the FSM system did not save appreciable energy. Improper tuning that results in a “very aggressive” control setting is a “common occurrence in the field.”

Seem (1998): “The HVAC industry is a cost-sensitive business, and people installing and commissioning systems do not have a long time to tune loops. Consequently, some PI algorithms use the default control parameters shipped with the controller.” The default parameters are often not appropriate (too aggressive) for the system and can result in control oscillations between operating states in an AHU.

Seem (2001): Ultimate annual energy savings range from 5% to 30%; estimates 20-30% for poorly tuned systems (which are often tuned for worst-case scenarios). Can avoid simultaneous heating and cooling.

Cost Information/Data and Source:

Summary: FSM control systems are slightly more expensive, mainly because of the added programming required during installation.

Seem (2001): Johnson Controls has deployed finite state machine control in VAV systems. They find that it reduces cost by reducing installation labor. FSM control systems do not add much cost, “merely” the programming of additional control algorithms in different regimes. The equipment costs are about the same.

Non-Energy Benefits of Technology: Improved control can enhance occupant comfort. Maintenance costs may also decrease because reduction of system oscillation reduce wear and tear on valves, dampers and actuators.

Notable Developers/Manufacturers of Technology: NIST, Johnson Controls (looks to eventually deploy in building EMSs).

Peak Demand Reduction: No. The energy savings of FSM control systems occur during transitional heating and cooling load periods (shoulder seasons, mornings, and evenings), when the electric peak is not likely to occur.

Most Promising Opportunities for Technology, Location(s) and Application(s): Buildings and equipment that are prone to poor control system tuning and commissioning (small to moderate buildings with packaged rooftop units for example).

Perceived Barriers to Market Adoption of Technology:

House (2001): Manufacturers are unwilling to change; Energy savings is not a priority for most building managers. Also, changing the control scheme is less likely than changing the type of heat exchanger or fan. Straightforward changes are easier to promote than more complicated ones.

Seem (2001): Long product cycle for HVAC systems (5-10 years).

Technology “Next Steps”: Deployment and demonstrations to show benefits and costs. Analysis of actual HVAC control system performance. Field research to assess effectiveness of control systems and their settings.

References:

ASHRAE, 1999, **ASHRAE Handbook: Applications**, American Society of Heating, Refrigerating and Air-Conditioning Engineers, Inc., Atlanta, GA, pp. 40.3-40.22.

House, J.M., 2001, Personal Communication, Iowa Energy Center.

Seem, J., 1998, “A New Pattern Recognition Adaptive Controller with Application to HVAC Systems”, *Automatica*, vol.34, no.8, pp. 969-982.

Seem, Park, and House, 1999, “A New Sequencing Control Strategy for Air-Handling Units”, *International Journal of HVAC&R Research*, vol. 5, no. 1, pp. 35-58.

Seem, J., 2001, Personal Communication, Johnson Controls.

Technology Option: Direct-Contact Heat Exchanger

Description of Technology: In traditional heat exchangers a solid layer of metal (or other thermally conducting material) separates the two fluids, but in a direct-contact heat exchanger the two fluids mix together to directly exchange heat with each other. Examples of commercial HVAC direct-contact heat exchangers include furnaces (where combustion gas is forced through the water as bubbles), cooling towers (where cooling water is evaporatively cooled via direct contact with cooling air) and humidifiers (where steam or water jets are sprayed into air and evaporated). Direct-contact heat exchangers could also be used in the condensers and evaporators of vapor-compression air-conditioning cycles, and have been used successfully in chillers that use water as a refrigerant. Since direct-contact heat exchangers have realized widespread use in cooling towers, this study focuses on boilers and vapor-compression air-conditioning cycles.

Description of How Technology Saves Energy: Comparing similarly sized heat exchangers, a direct-contact heat exchanger is more effective than an indirect-contact heat exchanger because of much lower thermal resistance between the hot and cold fluids. Consequently, chiller and air-conditioner efficiencies improve because the direct-contact heat exchangers (condenser and evaporator) reduce the temperature lift across the compressor. In furnaces and boilers, a direct-contact heat exchanger improves thermal efficiency.

Technology Technical Maturity: New; currently used in cooling towers, as well as numerous industrial processes.

Systems/Equipment Impacted by Technology: All liquid-gas heat exchangers.

Readily Retrofit into Existing Equipment and Buildings: No.

Total Primary Energy Consumption by Systems/Equipment Impacted by Technology: 3.1 quads.

Performance Information/Data and Source:

Summary: While little information is available for direct contact heat exchangers, a simple analysis using general estimates for a vapor-compression chiller (using water as the refrigerant and the working fluid) indicates increases in cycle COP of about 35% when using direct contact heat exchangers for the evaporator and condenser. For a furnace or boiler, the efficiency is essentially the same as for a condensing unit (AFUE of ~93%, compared with ~72% for traditional unit). These savings are theoretical, and in practice there are many obstacles (see “Barriers” section) to using direct contact heat exchangers, e.g., they will not work directly with refrigerants other than water.

TIAX Calculation (2002): With a lack of available quantitative information on the efficiency improvement caused by direct contact heat exchangers in an air-conditioning system (condenser and evaporator), TIAX performed a simple calculation to quantify the COP improvement in vapor-compression air-conditioning equipment (using water as the refrigerant). In a traditional heat exchanger, a significant temperature difference must exist between the hot and cold fluids to drive heat transfer, but a much small temperature difference ($\sim 1^\circ\text{F}$) is needed for a direct contact heat exchanger. This decreases the temperature lift across the compressor and improves cycle efficiency. The results in close to a 40% COP increase (7.6 to 10.5) under the following conditions: original condenser refrigerant temperature of 95°F (85°F condenser water), original evaporator refrigerant temperature of 40°F (45°F chilled water), direct contact condenser refrigerant temperature of 86°F , direct contact evaporator refrigerant temperature of 40°F . The same cycle analysis yields a $\sim 35\%$ increase in COP for direct-contact heat exchangers for both R-22 and R-123 cycles.

Cost Information/Data and Source:

Summary: No quantitative data are available for cost data on direct contact heat exchangers. The material cost may be lower since no coils are needed, but the equipment needed to separate the refrigerant or combustion gas from air or water may substantially increase system cost.

Non-Energy Benefits of Technology: Reduction in heat exchanger materials (no coils); no need for additional condensate recovery/removal in condensing boilers and furnaces.

Notable Developers/Manufacturers of Technology: None found.

Peak Demand Reduction?: Yes.

Most Promising Opportunities for Technology, Location(s) and Application(s): Condensing boilers/furnaces and water-refrigerant chillers are proven, and are the most promising applications.

Perceived Barriers to Market Adoption of Technology:

Direct contact heat exchangers are a broad topic, best organized into three main categories: hydronic heating systems, water-refrigerant air conditioning cycles, and traditional-refrigerant air conditioning cycles. In all systems, separation of gas from liquid poses a major a challenge (costly to address) and improper separation can lead to corrosion, flashing (noise and knocking in pipes), and degradation of lubricants. Other problems and issues are separated by category:

Hydronic Heating Systems:

- The combustion gas will tend to form a build-up of damaging substances (e.g., sulfuric acid) in the condensing furnace, boiler, or water heater;

- The combustion gasses may require pressurization to achieve the hydronic system pressure, adding cost and inefficiency to the system.

Water-Refrigerant Cycles:

- Non-condensable gases in water (such as air);
- Water directly mixed into air in ducts creates a fertile environment for biological growth;
- The refrigerant must be pressurized to match the chilled water loop pressures, often requiring multi-stage compressors (added cost and inefficiency).

Consequently:

- Water-refrigerant cycles are large and costly.

Traditional-Refrigerant Cycles:

- Refrigerant in the water loops (or open to air) will likely increase refrigerant loss (adding cost and increasing the system GWP);
- Equipment for separating gas and liquid would likely be expensive and complex;
- Air in the refrigerant loop can cause corrosion and/or lubricant (e.g., for POE) breakdown.

Technology “Next Steps”: More detailed study of the performance benefits and system costs.

References:

Air-Conditioning and Refrigeration Institute, 1998, “Standard for Water Chilling Packages Using the Vapor Compression Cycle”, ARI Standard 550/590-1998.

Air-Conditioning and Refrigeration Institute, 1999, “Standard for Positive Displacement Refrigerant Compressors and Compressor Units”, ARI Standard 540-1999.

Technology Option: Dual-Compressor Chillers

Description of Technology: Most large (500 tons +) chiller applications (about 85% according to Lord, 1999) use two single-compressor chillers working together in parallel. A dual-compressor chiller (possessing two centrifugal or screw compressors instead of one) replaces the traditional two-chiller system with a single chiller, with the dual-compressor system sharing evaporator and condenser coils. Both dual-chiller and dual-compressor chiller systems operate so that only one chiller or compressor operates if it can meet the entire load by itself; the other chiller or compressor turns on only when needed to meet peak cooling loads. The main difference between the two systems is the effective size of the condenser and evaporator when only one compressor is operating – in essence, dual-compressor chiller systems have much larger coils because they share evaporator and condenser coils.

Description of How Technology Saves Energy: Multi-compressor air conditioning equipment gives better part-load efficiencies than single-compressor equipment because the compressors cycle on and off so that each one operates in its most efficient operating regime. However, the part-load efficiency benefits of using more than one compressor for reciprocating and scroll compressors exceeds that of centrifugal and screw chillers because their performance degrades more at part-load efficiency degradation. In centrifugal and screw chiller applications, a dual-compressor chiller will save energy at part-load conditions versus the traditional two-chiller system because the condenser and evaporator – which are sized for the full-load condition – are effectively oversized for a single compressor. This, in turn, reduces the temperature lift across the compressor when only one compressor is running and increases system cycle efficiency.

Technology Technical Maturity: Current.

Systems/Equipment Impacted by Technology: Centrifugal and screw dual-chiller systems.

Readily Retrofit into Existing Equipment and Buildings: Yes.

Total Primary Energy Consumption by Systems/Equipment Impacted by Technology: 0.22 quads; all centrifugal and screw chillers (assumes all are presently multiple-chiller installations).

Performance Information/Data and Source:

Summary: Dual compressor chillers have IPLV performance values that are ~15-20% better than single-compressor chillers.

Watson (2001): estimates ~20% annual savings over two single-compressor systems based on a common load profile (for centrifugal compressors with same full-load kW/ton). Dual-

compressor system had an IPLV ~86% of the single compressor machines, or ~14% annual energy savings.

Fryer (1997): A dual-compressor screw chiller, which has a full load performance about 15% worse than a single screw chiller at full load, will realize superior performance below ~50% of load: about 10% better at 30% of full load, and about 20% better at 20% of full load. One half-sized compressor can actually provide 60% total capacity of a system due to the larger heat exchange surface

Cost Information/Data and Source:

Summary: Compared to single-compressor chillers, dual-compressor chillers cost 20-25% more. Assuming 1,000 full-load equivalent hours of operation a year at an average COP=5, a 25% cost premium translates into ~1.5-year simple payback period⁸⁴.

Watson (2001): Quoted dual-compressor prices (50%-50% capacity split) relative to single compressor prices for 500 to 1000 tons, and dual-compressor machines had an average ~25% cost premium relative to single-compressor machines; at capacities closer to 1000 tons, this decreased to ~20% cost premium.

TIAX Estimate: \$300/ton cost for single-compressor chiller.

Non-Energy Benefits of Technology: Smaller footprint than two-chiller system. The non-benefits of both systems include easy maintenance (of the compressor not operating) and allowing lower part-load conditions before compressor surge occurs (where the refrigerant “surges” backwards when the compressor operates below ~20-30% of full load, and hot-gas bypass is required).

Notable Developers/Manufacturers of Technology: McQuay (Centrifugal compressors); Dunham-Bush (Screw compressors).

Peak Demand Reduction: No. Peak electric loads coincide with peak cooling loads occur, and dual-compressor chillers only save energy during part-load operation (i.e., off-peak cooling periods).

Most Promising Opportunities for Technology, Location(s) and Application(s): Large buildings with large cooling loads (office, hospitals, etc.; in hot regions).

Perceived Barriers to Market Adoption of Technology: Increased first cost. Decreased system redundancy compared to a dual-chiller system (where each component has redundancy, not just the compressor).

Technology “Next Steps”: Promotion of benefits.

⁸⁴ Electricity cost = \$0.075/kW-h

References:

Frye, L., 1997, "Electric Chiller Buyer's Guide: Water-Cooled Centrifugal and Rotary Screw Chillers", *E-Source Tech Update*, July, E Source TU-97-7, pp.34-36.

Lord, R., 1999, "ARI Standard 550/590-98 Improves Chiller Specification but Requires a Better Understanding of the Standard", Forum on ARI Standard 550/590-98 sponsored by HPAC, last accessed January, 2002 at:
<http://www.hpac.com/member/feature/1999/may99/9905ari.html>.

Watson, T., 2001, Personal Communication, Tom Watson, Chief Engineer, McQuay International.

Technology Option: Dual-Source Heat Pump

Description of Technology: A dual-source heat pump (DSHP) has an airside heat exchanger as well as a ground loop and can pump heat to and from either. In essence, it is an air source heat pump (ASHP) modified to also allow use of a ground loop 1/3rd to 1/2 the size of an ordinary ground source heat pump. Depending upon the outdoor conditions, the system selects either the air or ground source for primary space heating or cooling; under some conditions, the system may use both devices.

Description of How Technology Saves Energy: The DSHP saves energy the same way that ground-source and air-source heat pumps save energy: by using a vapor compression cycle to transport thermal energy to the building in heating season and to the sink (usually, the ground) from the building during the cooling season. The moderate temperature of either the ground or air source decreases the lift of the cycle, improving its efficiency. The two thermal sinks give DSHPs the potential to exceed the performance of single-source heat pumps by allowing selection of the source which yields the lower temperature lift for a given set of outdoor and ground (or ground water) temperatures.

Technology Technical Maturity: Current.

Systems/Equipment Impacted by Technology: All heating and cooling systems, as well as the system to deliver the heating/cooling.

Readily Retrofit into Existing Equipment and Buildings: Depends; a DSHP requires installation of a ground loop, which may or may not prove feasible in many applications

Total Primary Energy Consumption by Systems/Equipment Impacted by Technology: 0.8 Quads (considering only Southern and Pacific climates, packaged and individual units, eliminating ~28% for difficulties of applying in high-density areas per GSHP).

Performance Information/Data and Source:

Summary: A DSHP can likely achieve ~30% efficiency gains relative to a conventional heat pump, offering energy savings potential in warmer regions of the country. DSHPs will probably not be used in colder climates, because the ground and air loops cannot effectively meet the heating loads (i.e., a GSHP rates as a better option for those climates).

FEMP (2000): Simulations predict that a 3-ton DSHP unit (17.2 EER cooling) applied in Georgia attains an heating season energy savings of ~15% and about 31% savings during the cooling season, both relative to a (simulated) high-efficiency ASHP, for annual normalized energy savings of ~25%.

TIAX Analysis: It is not clear that a properly-sized DSHP can realize performance approaching 17.2 EER because a DSHP uses down-sized ASHPs and GSHPs (e.g., 1/3rd to

½ the GSHP loop length). As a result, the GSHP incorporated into the DSHP cannot meet the entire cooling load as efficiently as a full-size GSHP. Instead, the DSHP pump will need to use the ASHP to meet the peak cooling load and/or use a much lower refrigerant evaporator temperature to increase the capacity of the undersized GSHP – both options result in less efficient performance than a conventional GSHP.

Cler (1997): Cites industry contact that estimates ~30% efficiency gain versus air-source units.

Glaze (2001): Estimates about 40% greater EER than 9.0 EER heat pump (~12.6), based upon 80°F ground temperature.

Cost Information/Data and Source:

Summary: DSHPs cost at least \$300/ton more than a conventional heat pump, based solely on the additional cost of the ground loop. Assuming the performance available from FEMP (2000), i.e., 17.2 EER, applying a DSHP in a Southern climate (i.e., Fort Worth) results in about ~6 year payback period relative to a packaged heat pump meeting ASHRAE 90.1 criteria (TIAX Calculation, \$0.07/kW-h). A 30% gain in EER results in a payback period of ~10+ years.

Nadel et al. (1998): In certain climates, DSHP costs may approach that of a top-of-the-line ASHP.

GSHP Data: A conventional GSHP loop costs ~\$1,000/ton to install, assuming a length of ~200 feet; a 40-foot loop used with a DSHP significantly decreases the loop cost.

Cler (1997): A DSHP uses 50% to 80% less loop length than a GSHP.

Glaze (2001): A 20-ton DSHP costs ~\$28K installed (or ~\$1,400/ton); ground loop of ~40 feet/ton used (estimated could use closer to 20 feet/ton, but add more to ensure customer satisfaction).

Non-Energy Benefits of Technology: Smaller footprint than a ground source heat pump. Potentially, DSHPs could provide water heating (i.e., heat rejection/pumping to hot water tank).

Notable Developers/Manufacturers of Technology: Global Energy & Environmental Research, Inc. (www.gegsolutions.com).

Peak Demand Reduction: Yes; excellent performance under peak load conditions.

Most Promising Opportunities for Technology, Location(s) and Application(s): Climates with larger cooling loads, e.g., in Southern U.S.; the small ground loop likely could not handle the larger heating loads experienced in cold winter locations.

Perceived Barriers to Market Adoption of Technology: First cost; verification of the performance and operating costs of installed systems. DSHPs have minimal market access and visibility at present. No rating standards exist specifically for DSHPs. Trained designers and installation contractors may not be available in most parts of the country.

Ray Bradford, WaterFurnace (2001, PC): WaterFurnace considered but decided against pursuing DSHPs because economics did not look favorable, geothermal looks better, and they viewed DSHP as niche (geographic) product.

Technology “Next Steps”: Confirmation of efficiency gains by independent organizations. Greater study of potential cost-energy savings.

References:

Bradford, R., 2001, Personal Communication, Water Furnace International, Inc.

Cler, G.L., 1997, “Dual-Source Heat Pump: A Sleeping Giant?”, *E-Source Tech Update*, TU-97-4, 1997.

FEMP, 2000, “Energy Savings from Dual-Source Heat Pump Technology”, Technology Installation Review, DOE/EE-0220.

Glaze, K., 2001, Personal Communication, Global Energy and Environmental Research, Inc.

Nadel, S., Rainer, L., Shepard, M., Suozzo, M., and Thorne, J, 1998, “Emerging Energy-Saving Technologies and Practices for the Building Sector”, American Council for an Energy-Efficient Economy (ACEEE) Publication, December.

Technology Option: Ductless Split Systems

Description of Technology: Many HVAC systems distribute heating and cooling via ventilation air from a central vapor compression unit to different locations in a building. A ductless split system has a central cooling and/or heating (AC or Heat Pump) unit that distributes the chilled refrigerant throughout the building, using fan-coil units at (1-to-3) different locations to transfer the heat from the refrigerant to the room. The “split” refers to the separate locations of the evaporator and condenser: the evaporator(s) lie at the fan-coil units inside the building, while the condenser(s) are outside of the building. In essence, ductless split systems are simpler analogs of VRVs, with less capacity and fewer evaporators. Mini-split systems are the main residential cooling system in Japan, and include features such as variable-speed fans and remote controls. They primarily would serve smaller commercial buildings.

Description of How Technology Saves Energy: By distributing cooling via refrigerant instead of air, ductless split systems save energy in at least two ways. First, air distribution requires much more energy to distribute the same quantity of cooling as refrigerant, owing to the major difference in heat capacity and density of air and refrigerants. The only fans required by a ductless split system are typically fan-coil units, which consume less energy than central ventilation units. Furthermore, ductless systems avoid cooling losses via duct leakage, which can approach 30% for light commercial installations (see “Improved Duct Sealants” option). Finally, multi-evaporator systems enable zoning of cooling, delivering cooling only to a zone(s) as needed. However, equivalent coil sizing (to typical forced air systems) is needed to realize the energy savings. Many split system designs fit into tight space and, consequently, have lower EER ratings.

Technology Technical Maturity: Current

Systems/Equipment Impacted by Technology: In theory, all HVAC. In practice, all units of less than 5 tons; larger systems fall under the “Variable Refrigerant Volume/Flow” classification.

Readily Retrofit into Existing Structures (no major structural modifications): Yes. One of the strengths of this type of unit.

Total Primary Energy Consumption by Systems/Equipment Impacted by Technology: 0.24 quads (PTACs/PTHPs, RACs, individual space heaters). If expanded to include all unitary equipment, the total grows to ~2.2 quads.

Performance Information/Data and Source:

Summary: Mini-splits save energy by reducing the air required to deliver cooling, avoiding any duct losses. Most commercially-available units have ~10SEER, so they do not save appreciable amounts of energy relative to RAC and PTAC/PTHPs. They save energy

relative to unitary A/C systems by reducing distribution energy consumption and eliminating duct losses (leakage and conduction), for a total energy savings on the order of ~15%.

Product Literature: Major manufacturers (Daikin, Mitsubishi, Sanyo) have units in 2-4 ton range. Sanyo units have a SEER=10.0.

Nadel et al. (1998): Savings are projected to be ~29% relative to duct-based systems for residences (e.g., central A/C or HP). TIAX: Assuming that half of leakage is to conditioned zone, savings ~15%.

Cler et al. (1997): Mini-split units have a SEER ~10.

Cost Information/Data and Source:

Summary: Mini-split units are very expensive relative to RACs and PTACs, as well as unitary equipment.

Nadel et al. (1998): Costs are typically \$3/ft² for mini-splits.

Cler et al. (1997, p. 218): *Engineered Systems* survey in 1994 of costs of 2-ton units, installed: A/C - \$2,765-\$4,350, HP - \$3,064-\$4,900.

Non-Energy Benefits of Technology: Zoning improves comfort. Reduced ducting requirements. Very compact units a benefit for retrofit/space-constrained applications.

Notable Developers/Manufacturers of Technology: Several in Japan, including Daikin, Mitsubishi, Sanyo.

Peak Demand Reduction: Yes. Peak ventilation rates are required to deliver peak cooling, so that ductless split systems realize the most savings under these conditions.

Most Promising Opportunities for Technology, Location(s) and Application(s): Drier climates; humid climates require humidity management, as well as sensible heat. Buildings with greater cooling loads.

Perceived Barriers to Market Adoption of Technology: Higher cost. Larger refrigerant charges and long refrigerant runs.

Technology “Next Steps”: Monitored demonstration projects. Explore application of microchannel heat exchanger to improve performance of dimensionally-constrained indoor fan-coil units, possible in combination with higher EER/SEER unitary outdoor units.

References:

Cler, G. et al., 1997, **Commercial Space Cooling and Air Handling: Technology Atlas**.
E Source, Inc.

Nadel, S., Rainer, L., Shepard, M., Suozzo, M., and Thorne, J, 1998, “Emerging Energy-Saving Technologies and Practices for the Building Sector”, American Council for an Energy-Efficient Economy (ACEEE) Publication, December.

Technology Option: Economizer

Description of Technology: Air-side and water-side economizers take advantage of cooler outdoor temperatures to reduce or eliminate the need for mechanical cooling. An air-side economizer brings in cooler outdoor air to cool a building when the outdoor air temperature (or enthalpy) falls below a chosen temperature or enthalpy set-point. In function, the air-side economizer system modulates both the outdoor air (OA) and return dampers to supply as much as the entire design supply air volume as outdoor air. Water-side economizers function in conjunction with chilled water systems and pass cooling water through an outdoor heat exchanger or cooling tower, rejecting heat to the cooler environment and achieving the desired chilled water temperature without using a vapor compression cycle.

Description of How Technology Saves Energy: By using outdoor air instead of a refrigeration cycle to cool a building, air-side economizer can eliminate much or most of air-conditioning loads that occur when outdoor temperatures fall below ~65°F (with sufficiently low moisture levels). In essence, an airside economizer replaces vapor compression cycle energy consumption with less intensive ventilation (fan) energy consumption. Analogously, water-side economizer reduce chiller loads by replacing chiller energy consumption with the pump energy required to push the water through the economizer heat exchanger. Additionally, night-time ventilation to pre-cool a building (using thermal mass heat storage) can extend the benefits of economizing even when the daytime hours are too warm for economizing.

Technology Technical Maturity: Current. ASHRAE Standard 90.1 prescribes air and water economizers (and their control systems) for buildings that require minimum cooling loads (for a given climate) exceeding minimum levels. Nastro (2001) indicated that economizers are an option on rooftop units and that most units sold have economizers.

Systems/Equipment Impacted by Technology: Cooling equipment, ventilation loads

Readily Retrofit into Existing Equipment and Buildings: Yes.

Total Primary Energy Consumption by Systems/Equipment Impacted by Technology: 2.8 Quads (all cooling energy and parasitics).

Water-side economizers tend to be limited to applications in colder climates that have substantial cooling loads independent of the outdoor conditions, i.e., the core regions of larger buildings.

Performance Information/Data and Source:

Summary: Proper economizer design, maintenance, and operation will save between ~1-40% in annual energy consumption for cooling, and depends on the allowable hours of economizer operation (which depends heavily on climate and operating criteria). Regulating

economizer operation using wet-bulb temperature (enthalpy) rather than dry-bulb temperature significantly extends the number of hours available for economizing. Moderate and dry climates have the largest potential for economizers.

Brecher (1998): In a Boston-area laboratory, chilled water economizers can realize about 2,400hrs/year of free cooling (i.e., no need to run vapor compression cycle), and an additional ~1,800hrs/year of partial cooling ($29^{\circ}\text{F} < T_{\text{wb}} < 40^{\circ}\text{F}$).

ADL (2000): Applied economizing in a 10-ton unitary unit for a small New York City office, binned weather analyses, combined with detailed operating models of the unit for each temperature bin, estimate that an economizer reduces annual cooling season energy consumption (parasitics plus compressors) by 9%. Simpler binned analyses for other climates suggest that savings will tend to be smaller (~5%) in the Southern and Mountain regions and potentially higher in the Pacific region. If used in conjunction with an energy recovery wheel, it is important to economizer *around* the wheel to avoid additional pressure drop/fan energy penalties.

Brandemuehl and Braun (1999): Economizers passing through and not by-passing energy-recovery devices (e.g., heat wheel or flat-plate heat exchangers) can create appreciable increases in fan power which can approach or even exceed the economizer energy savings. Hourly building simulations (DOE2 with TMY2 weather data) for three climates and four different building types predict annual energy savings (for cooling loads) ranging from 1 to 8% for temperature-based economizers, and 10 to 40% for enthalpy-based economizers. Enthalpy-based systems are far more effective than the temperature-based systems, particularly in drier climates where economizers can operate for more hours.

Brademuehl and Braun (1999): An economizer can dramatically improve the savings attained by the Demand-Control Ventilation strategy, in many instances enabling Demand-Control to save (versus consume additional) energy.

Cler et al. (1997): Night pre-cooling study showed that cooling *cost* savings from night ventilation cooling, 10-story office building, range from 5% (Phoenix) to 18% (Denver).

Cler et al. (1997, p. 154): Simulations of night cooling for a 100,000ft² office building (3 stories) showed possibility for up to 12.6% cooling energy reduction in Sacramento, 6.2% in Washington, DC.

Cler et al. (1997, p. 160): “In northern climates, the opportunity for free cooling with a water-side economizer typically exceeds 75% of the total annual operating hours. In southern climates such free cooling may only be available during 20% of the operating hours.”

Cost Information/Data and Source:

Summary: Economizer systems will payback in between ~2-10 years, depending on climate, operation, and system type (air-water or air-air economizer).

ADL (2000): Economizer system studied (10-ton unitary system in a NY office) gave a ~8 year simple payback period (for electricity cost of \$0.076/kW-h). For 10-ton Rooftop unit, ~\$500 price premium (\$186 cost, 2000cfm unit).

Cler et al. (1997, p. 152): Packaged unit costs ~\$50/ton over 10-ton units; ~\$100/ton for smaller units; built-up unit costs: \$20-200/ton, higher end for smaller systems. Water-side economizers typically have 2-5 year payback period (added costs include controls, heat exchangers, pumps and piping); all this comes with a central chiller/cooling tower design.

Non-Energy Benefits of Technology: When operating, air-side economizers improve IAQ by increasing the quantity of OA ventilation, resulting in more rapid elimination of indoor air pollutants from the building.

Notable Developers/Manufacturers of Technology: Numerous companies include economizers with unitary equipment.

Peak Demand Reduction?: No. Temperatures during peak periods exceed economizer set-points (~60°F).

Most Promising Opportunities for Technology, Location(s) and Application(s): Buildings with higher internal loads, high ventilation requirements, and nighttime occupation (hospitals, hotels, and university buildings for example). Climates that are seasonal and dry will have the most hours of potential economizer operation.

Perceived Barriers to Market Adoption of Technology: Added first-cost and design challenges (bypassing equipment, installing dampers and sensors, controls). Very high malfunction rates in the field. Enthalpy sensors are perceived as costly and unreliable. Require regular maintenance. In spite of these barriers, ASHRAE Standard 90.1 virtually requires economizers.

Johnson (2001): A survey of ~900+ commercial buildings showed that most of the economizers did not function properly, primarily due to actuator failure, disablement by occupants, and failed sensors (temperature and enthalpy); survey for California market.

CEE (2001): Cites study where ~75% of economizer on rooftop units malfunction (frozen, broken disconnected linkages, dampers and actuators, sensor malfunction), often consuming more energy.

Technology “Next Steps”: Purchase incentives, design for less-maintenance and higher reliability.

References:

ADL, 2000, “Energy Efficient Rooftop Air Conditioner: Continuation Application Technical Progress Statement”, Presentation on 7 November, Project #: DE-FC26-99FT40640.

Brandemuehl, M.J. and Braun, J.E., 1999, “The Impact of Demand-Controlled and Economizer Ventilation Strategies on Energy Use in Buildings”, *ASHRAE Transactions*, vol. 105, part 2.

Brecher, M.L., 1998, “Designing for Efficiency”, *Engineered Systems*, October, 1998, pp. 46-54.

Cler, G. et al., 1997, **Commercial Space Cooling and Air Handling: Technology Atlas**. E-Source, Inc.

Consortium for Energy Efficiency (CEE), 2001, “Guidelines for Energy-Efficient Commercial Unitary HVAC Systems”, Final Report, January 19, 2001.

Johnson, J., 2001, Personal communication, New Buildings Institute.

Nastro, T., 2000, Personal Communication, Trane Company.

Technology Option: Electrohydrodynamic (EHD) Heat Transfer

Description of Technology: Heat exchanger refrigerant-side design focuses heavily on reducing the thermal resistance at the fluid-surface interface. Conventional design approaches have focused on disrupting the fluid boundary layer to reduce its thickness and thus its thermal resistance (by adding ridges to the wall for example). Electrohydrodynamic (EHD) heat exchanger designs use electrodes suspended in the fluid to create a high-voltage (1,500-2,500V) but low-current (1mA or less) electric field between the heat exchanger surface and the electrode. The electric field induces secondary fluid motion in the fluid boundary layer thus reducing thermal resistance. The result is a heat exchanger with higher effectiveness than a conventional design with the same surface area.

Description of How Technology Saves Energy: EHD can enhance heat transfer in any heat exchanger that uses low-conductivity fluid (such as refrigerant or air), but it is most effective when used with liquids. As such, EHD is most useful in air-conditioning applications when the electrodes are placed on the refrigerant-side of the evaporator to raise the convection coefficient between the liquid refrigerant and the wall. This arrangement allows a higher evaporator refrigerant temperature for a given airside temperature and surface area, which reduces the overall cycle lift and increases the COP.

Technology Technical Maturity:

Advanced. Researchers have teamed up with industrial partners, though production remains at the prototype level.

Systems/Equipment Impacted by Technology: Vapor-compression air-conditioning systems.

Readily Retrofit into Existing Equipment and Buildings: No.

Total Primary Energy Consumption by Systems/Equipment Impacted by Technology: 1.4 Quads (all compressors).

Performance Information/Data and Source:

Summary: Depending on the electrode design, heat exchanger surface, and working fluid, EHD enhances the convection heat transfer coefficient in a heat exchanger by 300 - 1000%. When used in the evaporator of a vapor-compression air-conditioning cycle, EHD improves the system COP by about 10 to 20%.

TIAX Calculations (2001): With a lack of available quantitative information on the efficiency improvement caused by EHD in an air-conditioning system, TIAX performed a simple calculation to quantify the COP improvement in vapor-compression air-conditioning equipment. Assuming that the air-side and refrigerant-side resistances account for $2/3^{\text{rd}}$ and $1/3^{\text{rd}}$ of the heat transfer resistance, a 300% enhancement of the refrigerant-side convection

coefficient decreases the temperature gradient between the refrigerant and the air by ~25%. For an air-cooled system using R-22, EHD applied only to the evaporator results in a ~5% increase in system COP; applying it to both the evaporator and condenser decreases system COP by ~20%⁸⁵. The resulting increase in cycle COP is ~50% (3.5 to 5.3) under these typical operating conditions: R-22 refrigerant.

ASHRAE (1997): Heat transfer is enhanced by 300-1000% depending on electrode design (voltage, polarity, pulsed versus steady, electrode geometry and spacing), heat exchanger surface (geometry, roughness, and thermal conductivity), and working fluid (electrical conductivity, temperature, mass flow, and density). Pressure drop is much less than with other heat transfer enhancement techniques (rotation, injection, and vibration techniques). EHD systems use relatively little electric power despite large voltages (up to 2,500V) because they use small currents (1mA or less). EHD systems consist of a transformer, insulators, and a wire, tape, or mesh electrode placed parallel and adjacent to the heat exchanger wall.

Cler et al. (1997, page 321, from Ohadi, 1994): Heat transfer is enhanced by 300-500% in condensers and evaporators of direct-expansion refrigeration systems. COP of refrigeration system increases with heat transfer enhancement: 9% COP increase for 100% enhancement, 12% COP increase for 200% enhancement, 13% COP increase for 300% enhancement. A prototype EHD condenser in a 15-ton refrigeration system consumed <8W of electricity.

Ohadi et al. (1998): Reducing the separation between the electrode and the heat exchanger surface significantly reduces the required voltage (< 2 kV), but in such cases insulating the electrode from the heat exchanger wall is essential to avoiding short-circuits. These lower-voltage electrode types can be applied on the air-side (finned-side) of heat exchangers where the thermal resistance is greater than on the fluid-side. In gasses, heat transfer is enhanced by corona discharge (sometimes called ionic wind) produced by EHD, while in fluids EHD produces boiling at the heat exchanger surface. EHD is most effective in laminar and transitional fluid flow since turbulent flow already promotes good mixing near the boundary layer.

Cost Information/Data and Source:

Summary: A balance exists between performance and cost with EHD heat exchangers. Compared with conventional heat exchangers with the same performance, EHD heat exchangers use less material (reducing costs) but will add electronics (increasing costs), so the costs will be similar between the two designs (The goal of current research is to integrate EHD into heat exchangers without increasing the overall cost. This is accomplished through the reduction of materials required for the same level of performance (Ohadi). To save energy, however, the EHD heat exchanger must perform better than the conventional design and will cost more since it will use the same amount of material as the

⁸⁵ Base case: condenser temperature = 130°F (95°F surrounding air), evaporator temperature = 45°F (80°F surrounding air); EHD case: condenser temperature = 121°F, evaporator temperature = 48°F.

conventional design while adding the cost of electronics. Payback periods are difficult to estimate without quantitative cost information. Numerous hermetic seals where electrodes would pass through the end turns will increase the manufacturing cost significantly.

There is a lack of quantitative cost data for EHD heat exchangers.

Non-Energy Benefits of Technology: EHD heat exchangers present a trade-off between energy savings and size. Heat exchangers can either be more effective (saving energy), or they can have the same effectiveness as conventional heat exchangers while being smaller and using less material.

Notable Developers/Manufacturers of Technology:

The University of Maryland (Ohadi) has established the AHX/EHD Consortium to further develop EHD: Allied Signal, ITRI, LG Electronics, NASA, York International, Samsung, Swales, SABROE, Thermo King, Wolverine Tube, Wieland, Heatcraft, ATEC, DOE, and Modine.

Peak Demand Reduction: Yes.

Most Promising Opportunities for Technology, Location(s) and Application(s): EHD is most attractive to manufacturers of air-conditioning systems and heat exchangers where reduced size and weight are critical (automotive, aeronautic and space applications). It is also attractive for technologies that want to improve energy-efficiency but are currently limited by heat exchanger size (HVAC retrofits for example).

Perceived Barriers to Market Adoption of Technology: Cost of applying electronics in actual systems (e.g., electrode seals), reliability, safety (high-voltage electricity), and need to demonstrate efficiency gains in actual systems.

Technology “Next Steps”: Study to assess the cost implications of EHD integrated into a commercial cooling system. Deployment and field testing of EHD technology in actual systems and equipment to understand performance and operational issues.

References:

ASHRAE, 1997, **1997 ASHRAE Handbook: Fundamentals**, ASHRAE Press: Atlanta, Georgia, pp. 3.15 – 3.17.

Cler, G. et al., 1997, **Commercial Space Cooling and Air Handling: Technology Atlas**, E-Source, Inc.

Ohadi, M.M., Li, S.S., and Dessiatoun, S., 1994, “Electrostatic Heat Transfer Enhancement in a Tube Bundle Gas-to-Gas Heat Exchanger”, *Journal of Enhanced Heat Transfer*, vol. 1, no. 4., p. 327-335.

Ohadi, M.M. and Dessiatoun, S.V., 1998, "Electrohydrodynamic Enhancement of Heat Transfer", U.S. Patent 5,769,155, Granted 23 June.

Ohadi, M.M., "Smart and Small Thermal Systems Laboratory Website", The University of Maryland, Department of Mechanical Engineering,
www.wam.umd.edu/~ohadi/research/index.htm, last accessed November 20, 2001.

Technology Option: Electrostatic Precipitators

Description of Technology: Used in lieu of conventional filters, electrostatic precipitators use an electric field between two oppositely charged electrodes to charge particles flowing in a gas stream. Initially, in the ionization section, a large potential difference between two wires creates a charge on the particles. Downstream, collector plates (deployed in pairs, with a large voltage potential between them) draw the charged particles to the plates and cause the particles to deposit on the plates, from whence they are removed (via cleaning or vibration). Typical operating voltages range from 4 to 25kV. Electrostatic filters can be designed to operate at very high (up to 98%) collection efficiencies depending upon their design and the air flow rate (ASHRAE, 1996).

Description of How Technology Saves Energy: Electrostatic filters have a much smaller frontal area (while increasing the open flow area) than traditional fiber-based or baghouse impaction filters, which ideally would reduce the filter pressure drop and decrease blower energy consumption. In practice, electrostatic filters have similar pressure drops to fiberglass filters and often cannot function effectively with higher particle loading and are used in conjunction with pleated filter. As such, systems electrostatic filters consume more energy than conventional filters.

Technology Technical Maturity: Current. Electrostatic precipitators are widely used in industrial applications, as well as in HVAC.

Systems/Equipment Impacted by Technology: All supply and return fans (i.e., ventilation systems with filters).

Readily Retrofit into Existing Equipment and Buildings: Yes.

Total Primary Energy Consumption by Systems/Equipment Impacted by Technology: No more than 0.24 quads (an upper bound, based on internal study by ADL, 1999) showing that dirty filters can account for up to 20% of system pressure drop).

Performance Information/Data and Source:

Summary: Typically, electrostatic precipitators are used in conjunction with conventional filters to reduce the cleaning frequency of the precipitators, leading to higher system pressure drops. They provide superior dust removal relative to conventional filters.

ASHRAE (1996): In general, electrostatic precipitators provide superior particle removal characteristics relative to conventional filters (up to 98% arrestance versus 50 to 85% for panel or pleated filters). Fiberglass filters Typical electrostatic precipitator electric power consumption ranges from 20 to 40W per 1000cfm. Pleated extended-surface filters average ~0.5" (between 0.1" and 1.0") of pressure drop, which translates into 60W of pressure drop losses; assuming a 50% fan efficiency and 80% motor efficiency, this equals ~150W of

additional power draw. Electrostatic precipitator collection efficiencies decrease as the collector plates become covered with particulates.

Cler et al. (1997, p. 123): Electrostatic precipitators are often used with low-efficiency impaction filters (for larger particles), with a net system pressure drop greater than conventional filters.

CEE (2001): Low pressure drop pleated filters can have pressure drops as low as 0.1"; dirty filters can increase the filter pressure drop up to 20-fold.

Honeywell (2002): A series of electrostatic home filters rated for 1,200 to 2,000cfm have a pressure drop that "is approximately equal to that of a fiberglass filter"⁸⁶; it requires a maximum of 36W to operate.

Cost Information/Data and Source:

Summary: Electrostatic precipitators have a much greater first cost than conventional pleated filters. In contrast to pleated filters, they do not require regular replacement but require cleaning with detergent and water to maintain their efficiency (ASHRAE, 1996). The washing frequency varies greatly with operating conditions (i.e., particle loadings).

Abbas Quality Air Filters (2001): 12 pleated filters cost \$43 to \$58 (20"x25")⁸⁷.

Honeywell (2002): A 2,000cfm home electrostatic filter costs ~\$500⁸⁸. Recommended washing frequency varies from 10 to 180 days, depending on operating conditions.

Creech et al. (1996): Residential electrostatic precipitators cost from \$600 to \$1,200, including installation.

Cler et al. (1997, p. 123): One source estimated 2-3 times greater maintenance expense for powered electrostatic filters than conventional filters.

Non-Energy Benefits of Technology: Superior collection efficiency of smaller particles.

Notable Developers/Manufacturers of Technology: Numerous manufacturers.

Peak Demand Reduction: Yes. Highest ventilation rates typically occur at peak loads, when the ventilation system must use very large volumes of air to deliver required cooling.

⁸⁶ Product literature for the Honeywell F300E series, available at: http://electronicaircleaners.com/database/documents/honeywell_f300e_product_data.pdf.

⁸⁷ Product literature at: www.abbasqualityfilters.com.

⁸⁸ Price of \$492.09 for the Honeywell F300E1035 found at: <http://www.longviewweb.com/buy1a.htm>.

Most Promising Opportunities for Technology, Location(s) and Application(s):

Buildings requiring very high ventilation loads (e.g., food service), in locations with long cooling seasons.

Perceived Barriers to Market Adoption of Technology: Most electrostatic filter applications require a conventional filter to remove larger particles; higher first and maintenance costs than conventional filters.

Technology “Next Steps”: Development of low-maintenance electrostatic filter.

References:

ADL, 1999, “Energy Consumption Characteristics of Commercial Building HVAC Systems Volume II: Thermal Distribution, Auxiliary Equipment, and Ventilation”, Final Report for the U.S. Department of Energy, Office of Building Technology, State and Community Programs. Available at: <http://www.eren.doe.gov/buildings/documents/pdfs/comhvac.pdf> .

ASHRAE, 1996, **ASHRAE Handbook: HVAC Systems and Equipment**, ASHRAE Press: Atlanta, Georgia.

CEE, 2001, “Guidelines for Energy-Efficient Commercial Unitary HVAC Systems”, Final Report, Prepared for the Consortium for Energy Efficiency, January. Available at: http://www.ceeformt.org/com/hecac/Com_HVAC_spec.pdf .

Cler, G. et al., 1997, **Commercial Space Cooling and Air Handling: Technology Atlas**. E Source, Inc.

Creech, E., Barcik, M., and Byers, S., 1996, “Clearing the Air: Filters for Residential Forced-Air Systems”, *Home Energy Magazine*, July/August. Available at: <http://www.homeenergy.org/archive/hem.dis.anl.gov/eehem/96/960709.html>

Technology Option: Engine-Driven Heat Pump

Description of Technology: Traditional heat pumps use an electric motor to power the compressor that drives the cooling and heating cycles. An engine-driven heat pump eliminates most of the need for electricity by burning fuel at the point of use to power the compressor directly, thus avoiding energy conversion losses. In a heat pump, the waste heat from the engine can be recovered to supplement the heating cycle. While large higher-efficiency engines have emerged in the engine-driven chiller market, the engine-driven heat pump market typically relies on smaller less-efficient automotive-type engines. The Asian market is much more mature than the American market.

Description of How Technology Saves Energy: Depending on the engine used, the electric motor it replaces, and the efficiency of the electric grid, engine-driven heat pumps can reduce total primary energy consumption as compared to electric heat pumps. For example, a high efficiency (~45%) natural-gas fired diesel cycle engine has almost a 20% absolute efficiency gain relative to a ~27% efficient motor-electric grid (primary energy basis⁸⁹). This example is not typical, however, because the engine-driven heat pump market does not use high-efficiency (and high cost) engines. Instead the market calls for lower-cost engines with resulting efficiencies between 15-25%, which will not necessarily save energy versus typical electric compressor motors and the electric grid. An engine-driven heat pump's efficiency will increase if the waste heat from the engine is utilized to supplement the heating cycle.

Technology Technical Maturity: Current.

Systems/Equipment Impacted by Technology: All heating and cooling equipment except individual units.

Readily Retrofit into Existing Equipment and Buildings: Yes.

Total Primary Energy Consumption by Systems/Equipment Impacted by Technology: 2.9 quads.

Performance Information/Data and Source:

Summary: Most studies compare engine-driven heat pumps with typical electricity-driven equipment and suggest primary energy savings of up to ~25%, with larger savings for unitary equipment and much smaller savings for larger (e.g., centrifugal) chillers. The primary energy savings include any equipment efficiency improvements (COP or IPLV) and the avoided electric grid inefficiencies. IPLVs for engine-driven heat pumps range between 1.1 to 2.0 (heating cycle efficiencies tend to be higher than cooling cycle efficiencies).

⁸⁹ Assuming 85% electric motor efficiency and that the grid converts and distributes primary energy to electricity at a 30% efficiency.

Nowakowski and Busby (2001): Engine-driven heat pumps have full-load cooling COPs that vary by compressor type: ~1.0 for reciprocating compressors, 1.3-1.9 for screw compressors, and 1.9 with centrifugal compressors. IPLVs are higher, reaching 1.9 to 2.5 for water-cooled screw compressor and 2.5 for water-cooled centrifugal compressor units. Efficiency is increased ~15-25% by recovering heat from engine jacket and exhaust (up to 75% of heat is recovered). They found simple payback periods of between 2 and 10 years for engine-driven chillers applied in hospital applications over a wide range of climates (this includes using the “waste” heat to meet hot water heating loads).

Nowakowski (1996): Typical gas seasonal COP (SCOP, i.e., the integrated part-load value capacity divided by the integrated part load value gas input) of 1.3 (heating) and 1.1 (cooling) for a 4-pipe unit. Tests in 1990-1992 showed ~42% primary energy savings versus a 10 SEER electric heat pump, but only 26% versus a combination of an 80% efficient furnace and a 10 SEER electric air conditioner.

ASHRAE (2000): Example of an engine-driven heat pump has a COP (heat energy output divided by fuel heating value input) of 1.45 without heat recovery, 1.7 with heat recovered from the engine jacket, and 2.0 with heat recovered from the jacket and exhaust.

ADL (1995): Engine-driven chillers (no heat recovery) had an IPLV of 1.8 in 1995, with IPLV of 1.9 projected for Y2005. Adding heat recovery would increase the COP by 20 to 30%.

Goettl (2002): A 15-ton unit has a 1.3 IPLV, a 20-ton unit a 1.5 IPLV⁹⁰.

Fischer and Labinov (1999): Cite a seasonal heating COP of 1.44 and cooling season COP of 0.9 for an internal combustion engine-based engine-driven heat pump, *not* including parasitic energy (fans, blowers, etc.).

Cost Information/Data and Source:

Summary: The installed cost of engine-driven heat pumps ranges between \$600-\$1000/ton, depending upon unit size. The non-fuel operating and maintenance (O&M) cost is estimated between \$20-\$80/ton-year.

ADL (1995): For units larger than 200 tons without heat recovery, the 1995 retail cost was ~\$450/ton and installed cost ~\$600/ton. Non-fuel O&M cost ranges between \$20-30/ton/year.

Goettl (2001): A complete 20-ton unit costs ~\$1,000/ton installed; 15-ton unit costs ~\$1125-ton installed. Maintenance is required about every 4,000 operating hours (~once/year) at a cost of ~\$1,000/unit/year.

⁹⁰ For the NGED1800 and NGED2400 models, respectively.

Nowakowski and Busby (2001): Non-fuel O&M cost is \$0.02/ton-hour (~\$87/ton-year with 50% capacity factor). Overall economics are very dependent on demand charge structures, since engine-driven heat pumps reduce electric demand at peak hours.

Non-Energy Benefits of Technology: Reduces peak electric demand (and associated electric demand charges).

Notable Developers/Manufacturers of Technology: Originally commercialized in Japan (1987), later in US (1994), with ~30,000 unit market per annum in Japan (circa 1995). Four Japanese manufacturers dominate the market, in sizes from 2-50 tons: Sanyo, Yamaha (recently retreated from market), Yanmar, and Aisin-Seiki. Trane, York, Goettl, and Tecogen have brought engine-driven chillers to market in the U.S. GRI helped fund engine-driven heat pump programs in the U.S. resulting in products by York and Goettl. York stopped marketing its Triathlon engine-driven residential heat pump but Goettl still markets its engine-driven heat pumps.

Peak Demand Reduction?: Yes. Currently, this ranks as the primary driver for engine-driven chillers and heat pumps.

Most Promising Opportunities for Technology, Location(s) and Application(s): Larger buildings with consistently large cooling and heating (including water heating) demand, in locations with high electricity demand charges – hospitals.

Perceived Barriers to Market Adoption of Technology: First costs are higher than electric heat pumps (York Triathlon went off market because of high first cost). Owners will pay higher first costs for large engine-driven chillers (since they payback in a few years), but engine-driven heat pumps are smaller and owners are less willing to pay high first costs. Regular maintenance is essential with an engine (whereas electric motors rarely require maintenance) and leads to higher operating cost and more effort for a building owner. Pollutant discharges can also work against engine-driven heat pumps, as units must meet stationary source emission requirement (often requiring controls and/or catalysts). Noise and vibration is another perceived problem.

Technology “Next Steps”: First-cost reduction for higher-efficiency engines (currently, more-efficient engines are more expensive). Extend maintenance and overhaul intervals.

References:

ADL, 1995, “EIA – Technology Forecast Updates”, Final report to the U.S. Department of Energy (EIA), 7 June.

ASHRAE, 2000, **2000 ASHRAE Systems and Equipment Handbook**, ASHRAE Press: Atlanta, GA.

Fischer, S. and S. Labinov, 1999, "Not-In-Kind Technologies for Residential and Commercial Unitary Equipment", Oak Ridge National Laboratory Report, ORNL/CON-477, December.

Goettl, 2001, Personal communications with Dave Wonnacott and Jerry Baughman, Goettl Air Conditioning, Phoenix, Arizona.

Nowakowski, G.A. and Busby, R.L., 2001, "Advances in Natural Gas Cooling", *ASHRAE Journal*, April, pp. 47-52.

Nowakowski, G.A., 1996, "An Introduction and Status Update on Unitary Engine-Driven Heat Pumps", *ASHRAE Journal*, December, p.42.

Technology Option: Geothermal (Ground-Coupled and Ground-Source) Heat Pumps

Description of Technology: A ground-coupled heat pump uses the heat contained in the soil below the ground as a heat source for exchange with heat pumps to provide space heating or cooling. A similar device, a ground-source heat pump, exchanges heat with the local ground or surface water. The temperature of the soil or water below a certain depth approaches the mean annual temperature of that geographic location; in much of the United States, this temperature is $\sim 60^{\circ}\text{F}$. A fluid, typically water, flows through a long run of pipe placed in the earth in the constant-temperature region, where it exchanges heat with the surrounding soil and/or ground water. In soil applications, a grout material back-filled around the pipe (between the pipe and the soil) helps to improve the thermal contact between the piping and the surrounding soil. After exchanging heat with ground, the fluid exiting the ground piping loop passes through a heat pump, which “pumps” heat from the fluid to the building during the heating season, and from the building to the fluid during the cooling season.

Description of How Technology Saves Energy: The GCHP can save significant amounts of energy by taking advantage of the approximately constant temperature of the earth below a certain depth to greatly reduce the lift, i.e., the difference in refrigerant temperature entering the condenser and entering the evaporator, of cooling or heating equipment. A conventional vapor-compression cycle transfers heat between the outdoor air (say, $\sim 80^{\circ}\text{F}$) and the cooling coil temperature, typically $\sim 45^{\circ}\text{F}$, while the earth temperature ($\sim 60^{\circ}\text{F}$) decreases the GCHP temperature lift. Similarly, during the heating season, a GCHP can decrease the heat pump lift because heat is pumped between the heating coil temperature ($\sim 105^{\circ}\text{F}$) and the earth temperature ($\sim 60^{\circ}\text{F}$) instead of the outdoor temperature (often below 40°F). Lastly, the GCHP enables effective heat pump operation even when the outdoor temperature lies well below the balance point ($\sim 30^{\circ}\text{F}$), i.e., the temperature below which an air-source heat pump lacks sufficient capacity to meet the heating load, because the GCHP always pumps heat from the earth temperature. In general ground-source heat pumps have higher energy efficiencies than ground-coupled heat pumps, due to lower resistance to heat transfer between the piping and the water and additional convection of the pumped heat/cold away from the piping. In soils with little or no groundwater flow, heat build-up or draw down needs to be considered, and the best results are obtained with balanced annual heating and cooling loads.

Technology Technical Maturity: Current. El-Sharif (2000) notes that $\sim 500,000$ GCHPs are installed in US (mostly in residences). The Geothermal Heat Pump Consortium (GHPC), a six-year project, with \$35 million of DOE funding matched by $\sim \$65$ million of private funds (GeoExchange) has set a goal of selling $\sim 430\text{K}$ units per year in 2005.

Systems/Equipment Impacted by Technology: Heating and cooling systems

Readily Retrofit into Existing Equipment and Buildings: Depends upon ease of installing loop under local geological conditions.

Total Primary Energy Consumption by Systems/Equipment Impacted by Technology: 2.2 quads; Rafferty (2001) indicates that the very high loads per building footprint area and the proximity of buildings will dramatically limit the application of GSHPs in downtown areas of major cities. According to the Y2000 US Census, ~28% of the US population lived in towns with 100,000 or more people. Taking this as a rough proxy for the percentage of commercial buildings that cannot apply GSHPs and eliminating cooling loads provided by high-efficiency screw and centrifugal chillers⁹¹ yields an estimated 1.6 quads of potential equipment replacement by GSHPs.

Performance Information/Data and Source:

Summary: Very difficult to generalize; ASHRAE 90.1-1999 levels are somewhat representative of performance levels.

ASHRAE (1999): ASHRAE 90.1 standard: Ground Source HP: Cooling, 77°F entering fluid - 10.0EER (brine)/13.4 EER (water; as of 10/29/2001); Heating, 32°F entering fluid – 2.5 COP (Brine)/ 3.1 COP (water, as of 10/29/2001); Groundwater Source HP: Cooling, 70°F entering fluid=11.0EER, 59°F=16.2 EER(as of 10/29/2001, for 16.2 EER); Heating, 70°F entering water– 3.4 COP, 50°F water, 3.1 COP (10/29/2001, for 50°F).

ASHRAE (1999b): Local soil conditions have a large impact upon soil conductivity and, hence, required bore length/depth and system cost.

Kavanaugh (1996): Weather bin analyses for *homes* in Atlanta and Chicago showed that a 15SEER GSHP (COP~4.4) reduces primary energy consumption by 55% and 39% in Atlanta and Chicago, respectively (see Table A-2). TIAX Note: Commercial buildings would tend to have less heating and more cooling, which would tend to increase the energy savings of the GSHP.

Table A-2: Residential GSHP Energy Savings Calculations (from Kavanaugh, 1996)

Energy Metric	Atlanta GSHP	Chicago GSHP	Atlanta Furnace / AC	Chicago Furnace / AC
kW-h	6,067	9,123	7,536	2,715
Ccf-gas			616	1,306
Primary Energy, MMBtu ⁹²	66	100	146	164
% Savings, GSHP	55%	39%		

Outside the Loop (1998c): EPRI has recently released 17 new GSHP publications covering introductory topics, equipment directories, bore hole grout properties and installation guides, soil classification, anti-freeze solutions, and loop installation guides. Available at: <http://geoheat.oit.edu/otl/index.htm> .

⁹¹ This presumes that a cooling tower can provide lower water temperatures than the GCHP; in practice, this will vary with climate and ground conditions.

⁹² Assumes 1 kW-h=10,958 Btu of primary energy (BTS, 2000).

Cost Information/Data and Source:

Summary: The local geological conditions have a very strong influence upon the actual cost of any ground loop installation cost, e.g., unconsolidated soils can necessitate lined well holes that increase the loop cost three-fold (Rafferty, 2001). In general, GCHPs cost about \$1,000/ton, installed (not including in-building thermal distribution); ground-source heat pumps can cost significantly less, declining to \$200 to \$600/ton above 200 tons (depending upon well depth, system size, etc.). Horizontal trenches with coiled polyethylene “slinky” tubing can be more cost-effective than vertical boreholes, provided that the trenching work coincides with other excavation on the site (new construction). In practice, “slinky” installations may be limited for commercial buildings because they require a larger footprint than boreholes.

Rafferty (1995, 2000) on *Installed Loop Costs Only*: Groundwater system costs very sensitive to tonnage sizes, particularly <100 tons; in >200 tons range from \$200-\$600/ton (depending upon depth of wells, system size). Ground-coupled runs ~\$1,000/ton for all sizes (due to cost of installing loop); hybrid ground source systems (i.e., with cooling tower, but not including cooling tower) run \$500-\$600/ton over 100 tons.

Outside the Loop (1998): Loop costs typically fall in between \$2 and \$4 per foot of loop.

Outside the Loop (1998b): in Austin. GSHPs with classroom console units (no ductwork or ventilation air) were averaging \$3,000 per ton (\$9,000 for a three-ton system).

Amerman (2001): Hopes to reduce by 25% (for residences) by leveraging oil well technology, i.e., smaller diameter holes to improve pipe-ground conductivity and reduce bore hole length by ~15% (also decrease required volume of grout). In practice, they employ a much faster drill bit (3-4 times faster) and 500-foot continuous pipe reels to avoid stopping every 10 feet to add new pipe sections to expedite loop installation. They drill at angles of up to 30° off vertical to decrease the footprint needed to install loop; he estimates about ~3x more loop into same area relative to conventional techniques.

Brookhaven National Laboratory (2001): Developed grouts with up to three times the thermal conductivity of bentonite and neat cement, which analyses shown can reduce bore length by up to 22-35%.

Non-Energy Benefits of Technology: Can eliminate noisy and unsightly roof equipment, providing aesthetic advantage. In many instances, GCHPs reduce ducting runs by using multiple heat pumps distributed throughout a building to deliver conditioning, also providing a degree of zone control.

Notable Developers/Manufacturers of Technology: Geothermal Heat Pump Consortium (GeoExchange); The International Ground Source Heat Pump Association at Oklahoma State University; Geoheat Center (at the Oregon Institute of Technology); WaterFurnace International; ClimateMaster (up to 20-ton Unitary rooftop units).

Peak Energy Reduction: Yes. The GCHP saves the most energy during the periods of peak cooling loads, because that condition coincides with the greatest difference in temperature lift between conventional air conditioning and a GCHP.

Most Promising Opportunities for Technology, Location(s) and Application(s):

Buildings in climates with more extreme climate ranges (e.g., Midwest) and lack of competitively priced fuel (e.g., no gas). Buildings with large cooling loads and significant land availability for ground loop, in regions with more extreme heating or cooling seasons.

Perceived Barriers to Market Adoption of Technology: First cost of the ground loop. Potential legal issues with water source heat pumps and groundwater contamination. Contractor and building/HVAC system designer unfamiliarity with GCHP/GSHP. Buildings without sufficient real estate for ground loop installation can incur a substantial incremental cost premium over existing systems. Castle (2000) and Bradford (2001) note that many contractors come from a well drilling background and may not apply best practices, for example, they may use bentonite or neat cement grouts that have less than half of the conductivity of newer grouts, significantly increasing loop length and cost.

Technology “Next Steps”: Shonder (2000) suggests that the current design programs are reasonably effective (e.g., ~11% of mean difference in bore length recommended by different programs). Furthermore, Rafferty (2000) describes resources available to assess the local feasibility of GSHPs (maps, geological conditions, well reports, etc.). Instead, it appears that GCHPs would benefit most from a spreading of “best practices”, enhanced industry professionalism (Castle, 2000; El-Sharif, 2000; Bradford, 2001), e.g., via industry consolidation), and increased awareness of GCHP option with designers. Creative financing, e.g., installing GCHP via an easement and guaranteeing a fixed cost of cooling and heating for a set period of time (Castle, 2000), would help greatly in overcoming the first-cost disadvantage of GCHPs. *Energy Star* ground source heat pumps have come to market.

References:

Amerman, 2001, Personal communication, President of EnLink Geoenergy, Houston, TX.

Anstrand, D.E. and Singh, J.B., 2001, “Geothermal Lessons Learned”, *HPAC Engineering*, August, pp. 41-71.

ASHRAE, 1999b, “Geothermal Energy” in **1999 ASHRAE Applications Handbook**, ASHRAE Press: Atlanta, GA.

Bradford, R., 2001, Personal communication, WaterFurnace International.

Brookhaven National Laboratory, 2001, “Thermally Conductive Cementitious Grouts for Geothermal Heat Pumps”, Project Summary downloaded on 21 September, 2001, from: <http://www.bnl.gov/est/GHP111.htm> .

Castle, R., 2000, Personal Communication, EnLink Corp.

El-Sharif, W.M., 2000, “GeoExchange Market Development: The U.S. Experience”, *Proc. Heat Pumps in Cold Climates: Fourth International Conference*, 17-18 August, Aylmer, Quebec, Canada.

Geoheat Center: <http://geoheat.oit.edu/index.htm> .

Kavanaugh, S., and Gilbreath, C., 1995, “Cost Containment for Ground-Source Heat Pumps”, Final Report Submitted to the Alabama Universities-TVA Research Consortium and the Tennessee Valley Authority.

Kavanaugh, S., 1996, “Using Existing Standards to Compare Energy Consumption of Ground-Source Heat Pumps with Conventional Equipment”, appearing in: **Commercial Ground-Source Heat Pump Systems**, ASHRAE Press: Atlanta, GA.

Nadel, S., Rainer, L., Shepard, M., Suozzo, M., and Thorne, J, 1998, “Emerging Energy-Saving Technologies and Practices for the Building Sector”, American Council for an Energy-Efficient Economy (ACEEE) Publication, December.

OPT, 2001, “Success Stories”, US Department of Energy, Office of Power Technology; downloaded on 21 September, 2001 from: http://www.eren.doe.gov/power/success_stories/introduction.html .

Outside the Loop, 1998, “Letters, Comments, Questions, & Suggestions”, vol.1, no. 2, page 6.

Outside the Loop, 1998b, “Loop Contractors – Unsung Heroes Reach 11,000 GSHP Bores in Austin”, vol.1, no. 3, pp. 1 and 4.

Outside the Loop, 1998c, “Publications”, vol.1, no. 3, page 7.

Rafferty, K., 1995, “A Capital Cost Comparison of Commercial Ground-Source Heat Pump Systems”, appearing in **Commercial Ground-Source Heat Pump Systems**, ASHRAE Press: Atlanta, GA, pp. 1-7.

Rafferty, K., 2000, “A Guide to On-Line Geological Information and Publications for Use In GSHP Site Characterization.” *Proc. Heat Pumps in Cold Climates: Fourth International Conference*, 17-18 August, Aylmer, Quebec, Canada.

Shonder, J.A., 2000, “Comparison of Commercially Available Design Software for Closed-Loop Vertical Ground Heat Exchangers”, *Proc. Heat Pumps in Cold Climates: Fourth International Conference*, 17-18 August, Aylmer, Quebec, Canada.

Technology Option: Heat Pipes (Heat Recovery and Wrap-Around Coil Applications)

Description of Technology: Heat pipes enhance conductive heat transfer over relatively long distances (~1 to 4 feet). A traditional heat pipe consists of a sealed metallic pipe filled with a fluid (e.g., ethylene glycol or ammonia) in vapor-liquid equilibrium tilted so that the liquid collects at one end of the tube (lower end) and the vapor rises to the other end (upper end). The outside of a heat pipe is typically finned and divided into two isolated sections: the lower section exposed to “hotter” air, and the upper section exposed to “colder” air. The heat transfer process is a continuous three-step cycle of conduction, convection, and phase-change. First, the “hot” air heats and boils off the liquid inside the lower section of the heat pipe. Second, the hot vapor rises up to the upper section of the heat pipe and transfers heat to the “cold” air, causing the vapor to cool and condense. Third, the condensed liquid travels back down to the lower section (driven by gravity or wicking) to refresh the liquid supply at lower section of the heat pipe. Depending upon the application, heat pipes come in straight, curved, or even looped shapes, as long as the fluid can collect at the lower section of the pipe and the vapor can rise to the upper section.

While heat pipes may take on many forms for various applications (electronics, ground temperature regulation, HVAC, etc.), two common HVAC heat pipe applications exist: direct heat recovery, and wrap-around coils. In direct heat recovery applications, straight heat pipes are installed in a flat plate that separates an HVAC system’s exhaust air from its inlet air (to pre-heat or pre-cool the inlet air). In wrap-around coils, a heat pipe loop straddles the evaporator coil of an air conditioner so that the lower end lies before the evaporator coil and the upper end comes after the evaporator coil, serving to pre-cool and re-heat the air, respectively.

Description of How Technology Saves Energy: In heat recovery applications, heat pipes transfer heat from the exhaust air to pre-heat or pre-cool the inlet air, saving energy by reducing the load on air conditioner or furnaces. The heat pipe also increases the cycle efficiency of air conditioners by reducing the temperature lift across the compressor. In wrap-around coil applications, heat pipes both pre-cool and re-heat the inlet air. Reducing energy consumption by decreasing the sensible cooling load on the evaporator coil and by decreasing or eliminating the energy needed to re-heat the air after it has been over-cooled to remove moisture. As such, wrap-around heat pipes exhibit particular value in humid climates, where high humidity requires lower evaporator temperatures to effectively manage humidity. In both applications, the heat pipes increase the pressure drop through the system and increase fan power requirements, canceling a portion of the energy savings benefit.

Technology Technical Maturity: Current

Systems/Equipment Impacted by Technology: Heating and cooling systems (for heat recovery applications); cooling systems (for wrap-around coil applications). Heat recovery devices require that the air intake and exhaust are located next to each other.

Readily Retrofit into Existing Equipment and Buildings: Depends; in unitary equipment, adding a wrap-around coil will increase system pressure drop and can pose major space problems.

Total Primary Energy Consumption by Systems/Equipment Impacted by Technology: 2.1 quads total: 1.3 quads (for heat recovery applications – all central air conditioning systems and furnaces, heat pumps, and packaged units for heating); 0.83 Quads (for wrap-around coil applications – air conditioning systems in the Southern region of the U.S.).

Performance Information/Data and Source:

Summary: Wrap-around coils save between 10% and 30% of annual air-conditioner electricity consumption in humid climates, and the savings depend on climate and building type (climates and building types with higher latent load ratios will save more energy). The added pressure drop of the wrap-around equals ~0.5” of water (0.018-psi) at an airflow ~500cfm.

Thermacore (2002): The relative (to solid material) thermal conductivity of a heat pipe improves with length. Unlike solid materials, a heat pipe's effective thermal conductivity will also change with the rate of heat transfer. For a well designed heat pipe, effective thermal conductivity can range from 10 to 10,000 times the effective thermal conductivity of copper depending on the length of the heat pipe.

Wrap-around Coils

EPA (1995): A simulation of a wrap-around heat pipe coil at an EPA laboratory in Pensacola, Florida showed ~\$7,700 savings, or 10% of total annual electricity consumption for the building. The system was then installed in the building, and realized 14% savings in total annual energy consumption (\$10,000 in operating cost) per year. These results were in addition to reducing the average indoor humidity level in the building (75% to 65%) indicating that the original (non-wrap-around coil) cooling system could not handle the latent loads.

Heat Pipe Technology, Inc. (2002): In 14 commercial building case studies, wrap-around coils reduced the air-conditioning electricity consumption by between 13.4% (supermarket in Georgia) and 30% (library in Florida).

Cler et al. (1997, p. 181): A wrap-around coil added 0.4 inches of water column to the pressure drop of the system at 500 cfm. At 300 cfm, it added 0.17 inches of water column to the pressure drop.

Heat Recovery System

Petersen (2000): Heat pipes in heat recovery applications have a lower pressure drop than flat-plate heat exchangers with the same effectiveness. To determine actual performance, hourly simulations of annual weather and heating/cooling/ventilation are required.

Cost Information/Data and Source:

Summary: In favorable climates (i.e., hot and humid) wrap-around coil applications pay back in 1-3 years, with climate, building type, and utility rates having major influences on the economics. For heat recovery applications, however, flat-plate heat exchangers and heat/enthalpy wheels deliver similar savings, at lower costs.

Wrap-around Coil

EPA (1995): The Pensacola retrofit installation cost \$42,000 (versus \$30,000 needed to fix the humidity problem with additional mechanical cooling capacity – net cost of \$12,000) and saved \$7,700 in annual electricity costs, giving a simple payback of 15 months.

Heat Pipe Technology, Inc.(2002): In 14 commercial building case studies, wrap-around coils had a simple payback of 2-3 years (without utility rebate incentives) and 1-2 years (with Florida Power Corporation rebate program – one case gave \$100/kW peak load reduction in summer and \$60/kW peak load reduction in winter).

Cler et al. (1997, page 181): Installed cost of ~\$200-300/ton of cooling for wrap-around coil application.

Heat Recovery System

Petersen (2000): Estimates ~20% more expensive than flat-plate heat exchangers (~\$1.20/cfm).

Non-Energy Benefits of Technology: Permits down-sizing of air-conditioners in humid environments. Lack of moving parts enhances a wrap-around coil's reliability and reduces maintenance versus a conventional over-cool/reheat system. Reduced humidity levels improves occupant comfort and potentially enhances IAQ via reduced mold formation.

Wrap-around Coil

EPA (1995): Showed 22% reduction in required A/C capacity due to wrap-around heat pipe.

Heat Recovery System

Besant and Johnson (1995): Simulations of office building in a dry climate showed up to 30% boiler, and ~8% chiller and cooling tower size reduction.

Notable Developers/Manufacturers of Technology: Heat Pipe Technologies; Engineered Air; Thermacore; DesChamps (Sweden). Several OEMs use wrap-around coils in their equipment (GE and Lennox for example).

Peak Demand Reduction?: Yes. The energy recovery and wrap-around sensible load reduction is greatest at higher temperatures.

Most Promising Opportunities for Technology, Location(s) and Application(s): For wrap-around coils, buildings with a high outdoor air ventilation requirement, in regions with

high latent cooling loads (ACHRN, April, 2000). Examples of the most promising applications include hospitals, hotels, restaurants, and supermarkets in southern climates.

Heat Pipe Technology, Inc.(2002): Taco Bell and Burger King are implementing wrap-around coils in their standard building specifications for all restaurants “below the Mason-Dixon line.”

Perceived Barriers to Market Adoption of Technology:

Wrap-around Coils: First cost increase; new practice for many contractors.

Heat Recovery Systems: Heat pipes for energy recovery have fallen out of favor and are rarely specified, because of cost (flat-plate heat exchangers are cheaper, analogous efficiency), moving parts (tilt motor), and maintenance.

Technology “Next Steps”: Devices which by-pass coils when not in use, to avoid parasitic energy losses. Market promotion, awareness, inclusion in HVAC sizing/design software programs.

References:

Cler, G. et al., 1997, **Commercial Space Cooling and Air Handling: Technology Atlas**. E Source, Inc.

Environmental Protection Agency, 1995, “Heat Pipe Effectiveness Study – Gulf Breeze Laboratory Installation, Pensacola, Florida”, last accessed on February 19, 2002 at: <http://www.epa.gov/oaintrnt/intrnlp2/energy/hpipe.htm>.

Heat Pipe Technology, Inc., 2002, “Why Heat Pipes? – Case Summaries”, last accessed on February 19, 2002 at: http://www.heatpipe.com/mktg%20materials/case_summaries.htm.

Thermacore International, Inc., 2002, “Frequently Asked Questions About Heat Pipes”, Thermacore website last accessed on February 19, 2002 at: http://www.thermacore.com/hpt_faqs.htm.

Technology Option: High-Efficiency Fan Blades: Optimized blade for Each Application

Description of Technology: Fan manufactures mass-produce fans in a wide range of configurations and capacities. It would be technically feasible to make fan blades in shapes that are optimal for a given application and set of operating conditions. For example, a chiller condenser fan could be designed with blades optimized for the specific operating conditions that fan will encounter. In essence, this is an example of mass customization, applied to HVAC fans.

Description of How Technology Saves Energy: By making fan blades in shapes that are optimal for a given application and set of operating conditions, one can engineer a more energy-efficient fan for a given application than an off-the-shelf solution. For example, chiller condenser fans could operate more efficiently with a fan equipped with blades optimized for the operating conditions that fan would encounter. Much of fan energy (excepting vent fans) ends up as heat inside buildings, so decreasing fan energy consumption also reduces cooling loads.

Technology Technical Maturity: New.

Systems/Equipment Impacted by Technology: Potentially, all fans. In practice, only smaller fans with sheet metal propeller blades (e.g., condenser fans for RAC, PTAC, small unitary, and cooling towers) represent more likely applications.

Readily Retrofit into Existing Equipment and Buildings: Yes.

Total Primary Energy Consumption by Systems/Equipment Impacted by Technology: Up to ~1.3 quads; data for equipment listed above suggest an upper bound of ~0.09 quads (condenser and cooling tower fans).

Performance Information/Data and Source:

Summary: Custom-designed condenser fans can reduce fan energy consumption by ~15%.

ADL (1996) estimated that, for refrigeration applications, more-efficient fan blades custom-designed for each application could realize a 10-20% fan shaft power reduction.

ADL (2000): Changing conventional condenser fans to plastic injection molded condenser fan would reduce *total* cooling season energy consumption (i.e., blower, condenser fans, compressors) by about 2%.

Cost Information/Data and Source:

Summary: Custom-designed condenser fans have a simple payback periods on the order of 5 to 10 years.

ADL (1996): estimated that, for refrigeration applications, more-efficient fan blades custom-designed for each application would entail roughly a 100% cost premium. Payback periods were less than one year for all applications; this holds true after eliminating the reduction in cooling load gained by the more efficient fan blades. Adjusting for the ratio of the annual duty cycle of a refrigeration fan relative to a condenser fan, i.e., ~5:1, yields a payback period of around 5 years.

ADL (2000): For condenser fans, plastic injection molded condenser fan has a ~\$150 price premium over sheet metal fans, leading to about a 9-year payback period in New York City small office simulation.

Non-Energy Benefits of Technology: Potential to use slightly smaller motors, less noise and vibration.

Notable Developers/Manufacturers of Technology: Fan manufacturers are potential developers. Companies performing air flow research design custom fans and blowers for automotive cooling applications.

Peak Demand Reduction?: Yes. More efficient fans reduce the fan power consumption while also reducing the cooling load created by the fan energy dissipated as heat.

Most Promising Opportunities for Technology, Location(s) and Application(s): Smaller HVAC propeller-style fans, i.e., RAC, PTAC, and small unitary condensers.

Perceived Barriers to Market Adoption of Technology: First cost. New industry practice.

Technology “Next Steps”: More thorough analysis of cost-savings benefit. Cultivate HVAC-fan manufacturer partnership to develop more specific fans.

References:

ADL, 1996, “Energy Savings Potential for Commercial Refrigeration Equipment,” Final Report for the U.S. Department of Energy, Office of Building Technology, State and Community Programs, June.

ADL, 2000, “Energy Efficient Rooftop Air Conditioner: Continuation Application Technical Progress Statement”, Presentation on 7 November, Project #: DE-FC26-99FT40640.

Technology Option: High-Temperature Superconducting Motors (HTSM)

Description of Technology: Superconducting motors employ high-temperature superconducting (HTS) wires in the stator and/or rotor windings, as compared to copper wire in standard motors. HTS wires are made of ceramic oxides (e.g., using Bismuth) whose electric resistance decreases dramatically below a critical temperature, T_c (typically at least $\sim 80^\circ\text{K}$ versus 10 to 20°K for low-temperature superconductors). High-Temperature Superconducting Motors (HTSMs) require cooling of the motor windings to maintain operation below the critical temperature, which is typically carried out using liquid nitrogen or gaseous helium (Mulholland, 2000). Applied in a motor, HTSs radically decrease the resistance of the motor windings while increasing the allowable winding current density. HTSMs have yet to reach commercialization status, with only prototypes tested to date.

Description of How Technology Saves Energy: The dramatic reduction in motor winding resistance can greatly reduce the heat energy generated in the windings, reducing Ohmic losses.

Technology Technical Maturity: Advanced.

Systems/Equipment Impacted by Technology: Very large HVAC motors (e.g., centrifugal chillers).

Readily Retrofit into Existing Equipment and Buildings: No, for centrifugal chillers.

Total Primary Energy Consumption by Systems/Equipment Impacted by Technology: <0.1 quads; very limited HVAC potential, as larger motors targeted by HTSM manufacturers ($>1,000$ HP) are rarely used in HVAC applications, typically appearing only in very large centrifugal chillers (ADL, 1999).

Performance Information/Data and Source:

Summary: HTSMs could improve the efficiency of larger (more than several hundred HP) motors by 0.5 to 1.0%.

Reliance Electric (2001): HTSMs have \sim half of the losses of high-efficiency induction motors built today of the same rating (see: http://www.reliance.com/prodserv/motgen/b2776_1.htm). The APS and the DOE shows similar information for larger motors (<http://www.aps.org/dcmp/pubint2.html> ; http://www.eren.doe.gov/superconductivity/pdfs/potential_of_supercon.pdf).

Mulholland (2000): indicates 50% losses of conventional induction motor, 0.5-1.5% efficiency gain over high-performance motor; cooling costs are only $\sim 0.5\%$ of total energy consumption of motor.

Cowern (1994): A typical 5HP, three-phase motor has ~40% of its losses in stator resistance, and another 25% in rotor resistance losses. Thus, an HTSM could reduce motor losses by ~50%.

Cost Information/Data and Source:

Summary: In the size range of almost all motors used in HVAC applications today, HTSMs will likely not be cost competitive.

Mulholland (2000): For larger sizes (>~2000HP), commercialized HTSMs will cost 25-40% less than conventional motors due to their greatly reduced size and weight.

Walls (2000): At smaller sizes (<~2000HP), HTSMs become un-competitive because of the increased cost of the superconducting wire material relative to the motor efficiency improvements (D. Walls, ADL, 2000).

Lawrence et al. (2000): Commercialization of motors projected in Japan and Europe in 2006; U.S. later.

Non-Energy Benefits of Technology: Very-low resistance enables much higher (~100 times) current densities in superconducting wires than conventional copper wires, resulting in much smaller motors; estimates range from a 45% (DOE website; see above) to 80% reduction in motor size (Mulholland, 2000). Decreased winding heat dissipation should lower winding temperatures and increase winding lifetimes.

Notable Developers/Manufacturers of Technology:

The U.S. Department of Energy Superconductivity Partnership Initiative consists of: American Superconductor (wire manufacturer), Rockwell Automation/Reliance Electric (team leader), Air Products Corp. (industrial end user), Centerior Energy (Utility end user), and Sandia National Laboratories (supporting research). The IEA Annex 10, “Implementing Agreement on High Temperature Superconductivity” acts as a forum for international HTS research for up to 16 participating countries (See: <http://www.iea.org/techno/impagr/hosted/scond/scond.htm>).

Peak Demand Reduction?: Yes.

Most Promising Opportunities for Technology, Location(s) and Application(s): Very large chillers appear to be the only portion of the HVAC motor market suitable for HTSMs.

Perceived Barriers to Market Adoption of Technology: First cost; need to maintain cooling system.

Technology “Next Steps”: None.

References:

ADL, 1999, "Opportunities for Energy Savings in the Residential and Commercial Sectors with High-Efficiency Electric Motors", Final Report for the U.S. Department of Energy, Office of Building Technology, State and Community Programs. Available at: http://www.eren.doe.gov/buildings/documents/pdfs/doemotor2_2_00.pdf .

Cowern, E.H., 1994, "Conserving with Premium Efficiency Motors", *Proceedings of the World Energy Engineering Conference*, 7-9 December.

Lawrence, L.R., Cox, C. and Broman, D., 2000, "High Temperature Superconductivity, The Products And Their Benefits – 2000 Edition", ORNL Subcontract 4500006921. Available at: <http://mfnl.xjtu.edu.cn/www.ornl.gov/HTSC/prodben.pdf> .

Mulholland, M., 2000, Personal Communication, American Superconductor.

Walls, D., 2000, Personal Communication, Arthur D. Little, Inc.

Technology Option: Hydrocarbon Refrigerants

Description of Technology: Hydrocarbon refrigerants (propane, butane, isobutane, ethane, etc.) are used successfully in refrigeration equipment, especially isobutane in domestic refrigerators, but their inherent flammability presents technical and safety obstacles for widespread adoption in commercial air-conditioning systems. Recently, however, the commercial air-conditioning industry has revisited using hydrocarbon refrigerants as substitutes for HCFCs and HFCs. Propane and isobutane/propane mixtures in particular have been investigated since their thermodynamic properties are similar to R-22 and R-12 respectively. The primary motivation is the low global warming potential of hydrocarbons compared to HCFCs and HFCs.

Description of How Technology Saves Energy: The transport properties of hydrocarbons lead to increased refrigerant-side heat transfer coefficients, potentially decreasing the lift and increasing the efficiency of a vapor-compression air-conditioning system. Theoretical COPs with hydrocarbons, based on the thermodynamic properties, tend to be somewhat lower than with HCFC-22, comparable to HFC alternatives. If a secondary loop is required to connect the evaporator with the indoor cooling coil (to exclude flammable hydrocarbons from the interior space), a significant efficiency penalty is incurred. Again, the primary motivation for considering hydrocarbons is the low global warming potential of hydrocarbons compared to HCFCs and HFCs, as opposed to any inherent potential for higher efficiencies.

Technology Technical Maturity: Current

Systems/Equipment Impacted by Technology: All vapor-compression air-conditioning and heat pump systems.

Readily Retrofit into Existing Equipment and Buildings: Generally, no, due to safety code issues. For some small chiller applications, a hydrocarbon-based chiller could be substituted for a conventional fluorocarbon refrigerant-based chiller.

Sand et al. (1997): Propane is compatible with existing air conditioning equipment (fire safety considerations aside) because of it has similar thermodynamic properties as conventional refrigerants (HCFC-22 for example). Propane also uses the same lubricant (mineral oil) as most HCFC refrigerants.

Total Primary Energy Consumption by Systems/Equipment Impacted by Technology: 1.3 QUADS.

Performance Information/Data and Source:

Summary: Study of hydrocarbon refrigerants for air-conditioning equipment has focussed heavily on propane (R-290), which has very similar thermodynamic properties as HCFC-22

(a commonly used refrigerant). While slight performance increases (on the order of 5%) are theoretically possible by switching from common refrigerants to propane, when a secondary heat transfer loop is installed for safety reasons the efficiency actually decreases (10-20% in overall COP). The major opportunity, therefore, is in small positive displacement chiller applications.

Treadwell, 1994 (found in Sand et al., 1997): Propane has “slightly better capacity and performance” than HCFC-22 when tested in a 2.5 ton air-conditioner.

Radecker and Lystad, 1996 (found in Sand et al., 1997): A small (~5%) increase in overall heating COP resulted from replacing HCFC-22 refrigerant with propane in “hydronic, heating only heat pumps commonly used in Europe.”

Sand et al. (1997): Several methods are available for improving safety in a hydrocarbon refrigerant system including complete sealing of refrigerant loop, isolating propane loop outdoors by using a secondary heat exchange loop, sealing or re-location of wiring and fan/blower motor components, propane leak detectors. If a secondary loop is used to increase safety, the overall COP of a propane system is ~80% that of HCFC-22 and HFC-134a when used in a heat pump.

Rodecker and Goerocke (1996): A propane-based heat pump achieves a cycle COP of 6.5 versus 5.9 for HCFC-22 (10% increase) and 5.6 for R-407C (16% increase). The heat pump tested was a water-water system.

Fischer and Labinov (1999): “There is essentially no difference in efficiency between a heat pump using propane and the baseline electric heat pump using R-22”.

Cost Information/Data and Source:

Summary: Hydrocarbon air-conditioning systems are more expensive than traditional HCFC and HFC refrigerant systems because additional safety systems (sensors, secondary loops, etc.) increase the cost (by on the order of ~30%).

Treadwell, 1994 (found in Sand et al., 1997): Cost estimates for a 3.5-ton air conditioner using propane were 30% higher than for a comparable system using HCFC-22 (considering the modifications necessary to handle the flammable refrigerant).

Douglas et al. (1999): Cost estimates indicate that, without any additional safety modifications, a propane-based air conditioner would cost ~5% lower than a similar system using HCFC-22 (because of a smaller evaporator and condenser, and the lower cost of propane).

Fischer and Labinov (1999): Based on prior literature, they noted cost increases of up to ~35% to incorporate design changes required by hydrocarbon flammability concerns.

Non-Energy Benefits of Technology: Relative to CFC, HCFC, and HFC refrigerants, hydrocarbon refrigerants have a lower global warming potential (GWP ~20 relative to 1 for CO₂; from ADL, 2001). The indirect impact, however, will counteract the direct benefits if air-conditioning systems with hydrocarbon refrigerants are less efficient.

Notable Developers/Manufacturers of Technology:

Propane and propane/isobutane mixtures are used in Europe (especially Germany and the UK), specifically for residential refrigerators. In 1992 DKK Scharfenstein began marketing a propane/isobutane residential refrigerator in Germany. Today many major European appliance manufacturers market a propane or isobutane/propane residential refrigerator (Bosch, Siemens, Electrolux, Liebherr, Miele, Quelle, Vestfrost, Bauknecht, Foron, and AEG for example). Use of hydrocarbons in air-conditioning systems is limited and no major manufacturers were found that are marketing such equipment. In Canada, Duracool Ltd. markets three hydrocarbon refrigerants that they claim to be “direct replacements” for R-12, -22, and -502 (Powell, 2002); these have been used (in Canada) in ice machines and coolers, either with a secondary loop or set-ups similar to ammonia.

Peak Demand Reduction: Yes (to the degree that they improve cycle efficiency, improvements expected to be small).

Most Promising Opportunities for Technology, Location(s) and Application(s):

Summary: Since flammability of hydrocarbons is a major concern, applications that minimize the perceived risks will be most successful in the marketplace, e.g., unitary systems that do not use a large quantity of refrigerant charge are promising or split air-conditioning systems with a secondary loop that keep the refrigerant loop outside the building. Small capacity (with small refrigerant charge size) positive displacement chillers located outdoors have the most readily managed set of safety issues.

Sand et al. (1997. From UNEP, 1995): Chillers are an “unlikely” target for hydrocarbon refrigerants because the large quantity of flammable refrigerant charge is a perceived safety risk.

Perceived Barriers to Market Adoption of Technology: Flammability is the primary barrier to the adoption of hydrocarbon refrigerants in the commercial air conditioning market. Perceived safety concerns and the additional costs of adding safety enhancements to equipment have limited propane usage, especially in the United States and Japan.

Technology “Next Steps”: System testing to document the performance of hydrocarbons in real air-conditioning systems (i.e., with added safety measures).

References:

ADL, 2001, "Energy Consumption Characteristics of Commercial Building HVAC Systems Volume 1: Chillers, Refrigerant Compressors, and Heating Systems," Final report to the U.S. Department of Energy, Office of Building Technology, State and Community Programs, April. Available on-line at:
<http://www.eren.doe.gov/buildings/documents/pdfs/hvacvolume1finalreport.pdf> .

Douglas, J.D., J. E. Braun, E. A. Groll, and D. R. Tree, 1999, "A Cost-Based Method for Comparing Alternative Refrigerants Applied to R-22 Systems", *Intl. J. of Refrigeration*, vol. 22, no. 2, pp. 107-125.

Fischer, S. and S. Labinov, 1999, "Not-In-Kind Technologies for Residential and Commercial Unitary Equipment", *Oak Ridge National Laboratory Report*, ORNL/CON-477, December.

Powell, P., 2002, "European Push for HCs Reaches the United States", *ACHRNews*, February 4, pp. 10-12.

Radecker, H. and Lystad, T., 1996, "Propane, An Alternative Coolant for Heat Pumps", *Workshop Proceedings: Compression Systems with Natural Working Fluids*, Trondheim, Norway, IEA Heat Pump Programme, Report No. HPP-AN 22-1, October, pp.145-159.

Rodecker, A. and Goericke, P., 1996, "Practical Experiences of Heat Pumps with Hydrocarbons as Working Fluids", *International Energy Agency Conference on Heat Pumping Technologies Toward the Next Century: Applications and Markets*, Natural Resources Canada, pp.223-242.

Sand, J.R., Fischer, S.K., and Baxter, V.D., 1997, "Energy and Global Warming Impacts of HFC Refrigerants and Emerging Technologies," Report prepared by Oak Ridge National Laboratory for the Alternative Fluorocarbons Environmental Acceptability Study (AFEAS), U.S. Department of Energy.

Treadwell, 1994, "Application of Propane (R-290) to a Single Packaged Unitary Air-Conditioning Product", *ARI Flammability Workshop*, Arlington, VA, Air-Conditioning and Refrigeration Institute.

UNEP, 1995, 1994 Report of the Refrigeration, Air Conditioning and Heat Pumps Technical Options Committee, 1995 Assessment, Kenya.

Technology Option: IAQ Procedure/Demand-Control Ventilation

Description of Technology: Demand-control ventilation regulates the amount of outdoor air coming into a building based on varying occupancy levels. Historically, standards and building codes have prescribed a minimum outdoor ventilation rate that is fixed depending on maximum design occupancy and building type (20 cfm per person for office spaces for example). ANSI/ASHRAE Standard 62-2001, “Ventilation for Acceptable Indoor Air Quality,” offers two options for maintaining adequate ventilation, the ventilation rate procedure and the IAQ procedure, and building codes throughout the United States are currently adopting it. The ventilation rate procedure uses the traditional prescriptive method, i.e., a minimum quantity of *cfm* per person (based on maximum occupancy) for minimum outdoor ventilation. In contrast, the IAQ procedure allows designers to vary the outdoor ventilation rate (from 0% to 100% of the supply airflow rate) if the measured carbon dioxide (CO₂) level remains below a set level; in this case, CO₂ levels serve as a proxy for building occupancy. The addition of the IAQ procedure to the standard allows for demand-control ventilation in buildings. Just as thermostats regulate the amount of cooling or heating supplied to a building space, CO₂ sensors measure and regulate the amount of fresh air supplied to the building space for buildings using a demand-control ventilation strategy.

Description of How Technology Saves Energy: If a demand-controlled ventilation strategy calls for less outdoor air than a prescriptive ventilation strategy (over the course of the heating and cooling seasons), the annual energy required to heat or cool the outdoor air taken into the building decreases. In addition, lower OA requirements decrease the fan energy expended to introduce and expel the air from the building. Theoretically, demand-control ventilation could also allow a building operator to cut off the flow of outdoor air entirely for short periods during the day to save energy, e.g., during the warmest time of day in summer or the coldest time of day in the winter, as long as the CO₂ levels do not exceed the maximum threshold (a 700ppm inside/outside differential [Schell and Int-Hout, 2001]).

Technology Technical Maturity: Current.

Systems/Equipment Impacted by Technology: All HVAC except individual units.

Readily Retrofit into Existing Equipment and Buildings: Yes; requires installation of CO₂ sensors and control systems.

Total Primary Energy Consumption by Systems/Equipment Impacted by Technology: 4.1 Quads. All parasitic energy, all central and packaged cooling equipment and all heating equipment except unit heaters and individual space heaters.

Performance Information/Data and Source:

Summary: It is widely held that actual occupancy levels in U.S. buildings are significantly less than the design occupancy levels that conventional ventilation systems are set to

handle. Field experience indicates that actual occupancy levels are at least 25-30% less – and perhaps as much as 60 to 75% less for some buildings - than design levels. While no one study conclusively demonstrated what the national energy savings potential, available data suggested that DCV reduces ventilation, heating and cooling loads by 10-30%, with the ultimate energy savings depending on actual versus design occupancy level patterns, building type, and climate.

TIAX Analysis: Annual binned weather and building load data for VAV systems deployed in small office buildings in Fort Worth and New York City were analyzed, assuming that DCV enabled a 25% decrease in OA required. On average, the 25% decrease in OA resulted in a 13% decrease in annual ventilation energy consumption, a 15% decrease in heating energy, and a 7% reduction in cooling load⁹³. A 50% reduction in OA generates a 25%, 31%, and 14% reduction in ventilation energy, heating energy, and cooling load, respectively⁹⁴.

Brandemuehl and Braun (1999): The peak occupations for buildings often fall well below their design occupations (and almost always operate substantially below). According to their model, the *average* occupancies for most commercial buildings equals between 10% and 40% of the design (peak) occupancy, with schools at 60% to 70% of peak occupancy. Using these occupation patterns, they performed hourly simulations in several locations to determine the energy impact of DCV. Their analysis found that DCV reduced annual heating input energy for office buildings in Madison, Albuquerque and Atlanta by 27%, 38%, and 42%, respectively. An office using DCV (w/o an economizer) reduced the cooling load by ~15% in Atlanta and by ~5% in Madison⁹⁵, but lead to a very slight increase in cooling load in Albuquerque due to loss of “free cooling” from the excess OA. They also studied retail, restaurants, and schools, and found that DCV could dramatically increase cooling demand for buildings with higher OA requirements *and* large variations in occupancy, due to the loss of “free cooling”.

Schell, Turner, and Shim (1998): Using a simulation program to model a classroom with CO₂ based demand-controlled ventilation showed that the volume of outdoor air consumed over the course of one day was reduced by 25% compared with a fixed 100%-design ventilation rate.

E-Source (1995): Using a CO₂ based demand-controlled ventilation system in a Swiss auditorium resulted in a 79% cooling+ventilation energy savings in summer, and a 30% heating+ventilation energy savings in winter (savings are relative to a prescriptive ventilation strategy using timeclock controls for unoccupied setbacks).

Schell (2001): Approximately 70% of buildings in the United States are over-ventilated (by >25%), except in humid climates (where under-ventilation is common).

⁹³ For ventilation, heating, and cooling energy: Fort Worth - 11%/14%/9%; New York City – 15%/17%/5%.

⁹⁴ For ventilation, heating, and cooling energy: Fort Worth – 21%/28%/17%; New York City – 29%/34%/11%.

⁹⁵ These two data points estimated from plots in paper.

Timmons and Tozzi (2000): A building load simulation of a 10-screen movie theater in Dallas, Texas indicate ~25% savings in annual energy consumption when using a CO₂-based demand-controlled ventilation system. The building was conditioned by rooftop units with gas heating (one per theater); the baseline ventilation system provided 100% of the design ventilation rate for the building's 14 occupied hours and 20% of design ventilation rate for the remaining 10 unoccupied hours. Movie theaters will tend to have higher energy savings than other buildings because they have highly variable occupancy levels (partly filled theaters, changeover to ~zero occupancy between movie showings, etc.).

Turk et al. (1987): Of 38 commercial buildings sampled, the average outdoor air ventilation rate was ~59cfm per person (range: 10-178cfm). The design ventilation rate was 15-20cfm per person based on design occupancy, so actual occupancy was ~1/3 of the design occupancy on average. Building design occupancies are often very high relative to actual occupancies and even maximum occupancy in practice.

Cost Information/Data and Source:

Summary: CO₂ sensors cost approximately \$400-\$500 each (installed), and there is typically one sensor installed per zone (~2,000-3,000 sq. ft. each), but will likely require additional expenses to integrate it into building controls. Annual operating cost savings of \$0.05 to \$1.00 per square foot have been realized, with large variations created by the range of building types studied. Using a \$600 cost per sensor and \$20 in annual maintenance (calibration) expense, for a system serving 2,500 ft² at a cost of \$0.57/ft² (weighted average for commercial building expense, based on ADL, 2001 data), and reducing HVAC expenses by 20% results in ~2.5-year payback period.

Bearg (2001): Indoor CO₂ sensor costs ~\$400, one per zone (e.g., conference room, auditorium, etc.), requires ~annual maintenance.

Schell (2001): Sensor ~\$500/installation, typically 1 per zone (for VAV box, 2000-3000 foot zones), same as thermostats.

Schell and Int-Hout (2001): CO₂ sensors have dropped from ~\$500/sensor to about half that (contractor price); some manufacturers offering integrated temperature-CO₂ sensors. Observed operating cost savings from \$0.05-\$1.00+/ft² using CO₂-based demand-controlled ventilation.

Timmons and Tozzi (2000): A building load simulation of a 10-screen movie theater in Dallas, Texas indicate 25% savings in annual operating cost⁹⁶ when using a CO₂-based demand-controlled ventilation system. The building was conditioned by rooftop units with gas heating (one per theater); the baseline ventilation system provided 100% of the design ventilation rate for the building's 14 occupied hours and 20% of design ventilation rate for the remaining 10 unoccupied hours. Movie theaters will tend to have greater cost savings

⁹⁶ A constant electric utility rate of \$0.10/kWh was combined with a fixed \$7/MMBtu natural gas rate for the economic analysis.

than other buildings because they have highly variable occupancy levels (partly filled theaters, changeover to ~zero occupancy between movie showings, etc.).

Cler et al. (1997): Costs range \$495-\$821/unit; calibration for NDIR sensors should occur annually, and takes ~15 minutes/sensor; calibration kits \$300-400, with \$100 for a tank of calibration standard gases each. AirXpert system: costs ~\$45k plus \$3-\$5k installation labor, for 24 measurement points.

Non-Energy Benefits of Technology: DCV method quantifies the quality of the air in the building, so applying the method also ensures that the indoor air quality meets standards, potentially improving the comfort and productivity of the occupants and greatly decreasing the potential for “sick building” syndrome. On the other hand, if DCV reduces the actual OA inflow, it would increase the concentrations of contaminants relative to a building constantly ventilated at the design level. Monitoring of CO₂ levels can diagnose IAQ problems (identifying contaminated outdoor air for example) and also provides documented evidence that the IAQ in a building is maintained.

Notable Developers/Manufacturers of Technology: ASHRAE, Honeywell, AirXpert, Telair, Carrier.

Cler et al. (1997): Lists CO₂ sensor manufacturers and their characteristics.

Peak Demand Reduction: Yes. If maximum ventilation rate under the prescriptive option exceeds both the ventilation required to deliver cooling and that needed to fulfill ASHRAE 62, the IAQ method will reduce the cooling and ventilation energy at peak loads. Further, demand-controlled ventilation has flexibility to close fresh air dampers during the hottest hours in the summer (thus reducing electric load at times of peak electric load).

Most Promising Opportunities for Technology, Location(s) and Application(s): Densely populated buildings with large variations in occupancy (e.g., performance halls, movie theatres, conference rooms, food service, etc.). Naturally ventilated buildings or buildings with operable windows that have significant fresh air supplied by sources other than the ventilation system.

Perceived Barriers to Market Adoption of Technology: Contractors and designers may be held liable for systems that do not meet IAQ standards when using CO₂ sensors, especially if the sensors fail or are installed improperly (whereas if they use the prescriptive standard, there is less room for liability). Also, although CO₂ tends to correlate well with occupancy, it does not take into account the buildup of non-occupancy-related pollutants, e.g., fumes from copiers and printers, out-gassing from building materials, carpets, furniture, and vapors from cleaning supplies. In practice, many building operators likely do not want to know if the quality of the air in the building is substandard, as this creates a problem, both physical and legal, that was not detected beforehand. One system designer remarked that the IAQ method also demands more savvy system installation and operational personnel, both of which cost more and are not readily found. Maintenance of the CO₂

sensors is essential (typically annually), and calibration and accuracy issues still exist. IAQ procedure is a new concept for standards, and local building codes have been slow and hesitant to adopt it (often requiring additional permitting and verification if they do adopt it). Most HVAC control systems do not support CO₂ sensor input for ventilation control (requiring the installation of custom programming and controls).

Technology “Next Steps”: Address liability issues under non-compliance, e.g., if the outdoor air has IAQ problems, what does this mean for indoor IAQ liability? Further case studies that clarify the costs and benefits of using the IAQ method.

References:

Bearg, D., 2001, Personal Communication, AirXpert.

Brandemuehl, M.J. and Braun, J.E., 1999, “The Impact of Demand-Controlled and Economizer Ventilation Strategies on Energy Use in Buildings”, *ASHRAE Transactions*, vol. 105, part 2, Available at: <http://hbctechlit.honeywell.com/techlit/pdf/63-0000s/63-7063.pdf> .

Cler, G. et al., 1997, **Commercial Space Cooling and Air Handling: Technology Atlas**, E-Source, Inc.

E-Source, 1995, “Demand-Controlled Ventilation: Teaching Buildings to Breathe”, *E-Source Tech Update*, September, TU-95-10.

Schell, Turner, and Shim, 1998, “Application of CO₂-Based Demand-Controlled Ventilation Using ASHRAE Standard 62: Optimizing Energy Use and Ventilation”, *ASHRAE Transactions Symposia*, January 21, 1998, TO-98-21-1. pp.1213-1225. Available at: www.carrier-commercial.com/pdf_files/public/c0005020.pdf.

Schell, M., 2001, Personal Communication, Telaire, Inc.

Schell and Int-Hout, 2001, “Demand Control Ventilation Using CO₂”, *ASHRAE Journal*, February, pp.18-29.

Timmons and Tozzi, 2000, “Off-Peak Building Control Consideration Utilizing CO₂ Based Demand-Controlled Ventilation (DCV) with Large Packaged Rooftop Units”, Carrier Corporation Publication 833-015, September.

Turk, B.H., Brown, J.T., Geisling-Sobotka, K., Froehlich, D.A., Grimsrud, D.T., Harrison, J., Koonce, J.F., Prill, R.J., and Revzan, K.L., 1987, “Indoor Air Quality and Ventilation Measurements in 38 Pacific Northwest Commercial Buildings”, Lawrence Berkeley National Laboratory Report LBL-22315.

Technology Option: Larger Diameter Blowers and Fans

Description of Technology: A larger diameter blower or fan can provide the same air flow as a smaller device, at a lower blade velocity and motor speed (rpm). In an application, one would specify a larger diameter blower or fan.

Description of How Technology Saves Energy: Because a larger fan rotates more slowly than a smaller diameter fan while moving the same volume of air, it may use less energy (i.e., less drag) while developing the same pressure head. The blower discharge air has less velocity head that ends up being dissipated. The magnitude of the energy savings from a larger fan increases with a VAV system, where slower wheel speeds at part-loads are akin to an increase in fan diameter.

Technology Technical Maturity: Current.

Systems/Equipment Impacted by Technology: All fans.

Readily Retrofit into Existing Equipment and Buildings: Yes. If blower size increases too much, the blower housing size will grow (e.g., for unitary equipment).

Total Primary Energy Consumption by Systems/Equipment Impacted by Technology: 1.3 quads.

Performance Information/Data and Source:

Summary: Data collected from Ludwig (2001) and Loren-Cook product information (see Table A-3) shows that centrifugal blowers one or more sizes larger than the minimum blower size recommended for the application can achieve more than 20% (absolute) efficiency gain in both rooftop and air-handling unit applications, particularly for backward inclined and airfoil fans.

Table A-3: Larger Diameter Blower Efficiency Gains

Rooftop Blower	Static Efficiency		
	Forward Curved	Backward Inclined	Airfoil
15"	47%	42%	40%
16.5"	N/A	50%	48%
18"	53%	54%	63%
19.5"	N/A	58%	67%
21"	N/A	72%	70%
Air Handling Unit	Forward Curved	Backward Inclined	Airfoil
27"	51%	51%	57%
30"	58%	60%	63%
33"	N/A	68%	69%
36.5"	N/A	74%	77%

Forward-curved blowers cannot increase too much in size before they cannot meet the application conditions, i.e., fall short of providing the required pressure drop for the required volume flow rate. Larger blower size could increase blower entry/exit velocity profile issues, compromising efficiency gains and/or increasing cost by altering system design to manage transitions.

Based on product literature, smaller gains (up to ~10%) occur for larger diameter backward-inclined and airfoil exhaust fans.

Cost Information/Data and Source:

Summary: Data collected from Ludwig (2001) shows that payback periods for larger diameter blowers range from about 1 to 3 years, for both the rooftop blower and AHU applications (see Table A-4).

Table A-4: Larger Diameter Blower Simple Payback Periods

Rooftop Blower	Simple Payback Period ⁹⁷		
	Forward Curved	Backward Inclined	Airfoil
15"	N/A	N/A	N/A
16.5"	N/A	1.7	1.9
18"	3.6	2.8	1.5
19.5"	N/A	3.3	2.3
21"	N/A	2.7	2.8
Air Handling Unit	Forward Curved	Backward Inclined	Airfoil
27"	N/A	N/A	N/A
30"	2.7	1.45	2.6
33"	N/A	0.77	1.0
36.5"	N/A	1.86	2.4

Non-Energy Benefits of Technology: Quieter operation enabled by lower blade velocities; reduced vibration and, perhaps, maintenance. By virtue of their higher efficiency, larger diameter blowers could reduce the motor size required for a given application. In practice, higher efficiency blowers are not likely to significantly reduce motor sizes except perhaps in the case of very large AHUs. For example, a 10% efficiency increase (from 55% to 65%) for a 8HP air moving load translates into a 12.3HP versus 14.5HP motor requirement, both of which would likely be met with at least a 15HP motor.

Notable Developers/Manufacturers of Technology: Not Applicable. Numerous fan/blower manufacturers produce a full range of products.

Peak Demand Reduction?: Yes. Relatively speaking, a large diameter blower or fan will save the most energy at the maximum flow (velocity) condition, as the efficiency of a smaller diameter blower or fan will also increase at partial loads (e.g., for a VAV application).

⁹⁷ Electricity cost = \$0.075/kW-h, 2,000 operating hours per year.

Most Promising Opportunities for Technology, Location(s) and Application(s):

Unitary blowers, with backward-curved and airfoil blades replacing forward-curved blades. Applications with large ventilation requirements and high duty cycles (e.g., hospitals).

Perceived Barriers to Market Adoption of Technology: Contrary to current practice. Space constraints for blowers and appropriate ducting installation (HVAC typically last into building, must fit into existing, limited space; if not using larger ducting, appropriately sized upstream and downstream transition sections are important to create decent flow profile and minimize losses – if not done, efficiency gains could disappear). Space constraints are particularly important for unitary equipment, where even moderate increases in blower size could necessitate an expensive transition to a larger “box” size. First cost of larger device.

Technology “Next Steps”: More thorough cost-benefit study of larger diameter blower installations that take into account additional housing and ducting costs, as well as actual installation practice upon fan performance.

References:

Ludwig, R., 2001, Personal Communication of Loren-Cook Fan Performance and Cost Data, Alfieri Proctor Associates.

Technology Option: Low-Pressure Refrigerant Cycles

Description of Technology: Throughout the temperature range of HVAC applications, low-pressure refrigerants have a lower-pressure state than conventional refrigerants (e.g., HCFC-123 <40psia versus ~300psi for HCFC-22). Because of their thermodynamic characteristics over the temperature range encountered in HVAC applications, low-pressure refrigerants have inherently better theoretical thermodynamic cycle efficiencies than higher-pressure refrigerants. On the other hand, a lower pressure results in lower densities, which translates into higher volume flow rates and larger-diameter piping systems for low-pressure refrigerant systems. Historically, low-pressure refrigerants (especially CFC-11) have been used in large chiller applications with large energy demand, and correspondingly large energy savings potential. With the phase-out of CFC refrigerants, HCFC-123 has replaced CFC-11 in large chillers but has not been widely adopted in smaller chillers or unitary equipment. High-speed centrifugal compressors could extend the application range of low-pressure refrigerants downward to lower capacity systems. Water, another potential low-pressure refrigerant, is covered in the “Natural Refrigerants” discussion.

Description of How Technology Saves Energy: A vapor compression air-conditioning cycle is theoretically more efficient when it operates at temperatures and pressures well below the refrigerant’s critical point. The actual energy savings of an air-conditioning system using a low-pressure refrigerant depend partly on the theoretical cycle efficiency and partly on the equipment efficiencies (especially the compressor efficiency). Low-pressure refrigerants require higher flow rates and the compressor must accommodate more mass and volume flow (this means the compressor must be larger, faster or both).

Technology Technical Maturity: Current.

Systems/Equipment Impacted by Technology: All vapor-compression air-conditioning cycles.

Readily Retrofit into Existing Equipment and Buildings: No. Lower-pressure refrigerants cannot substitute for higher-pressure refrigerants in existing equipment. A new system designed to accommodate the properties of the low-pressure refrigerant would be required.

Total Primary Energy Consumption by Systems/Equipment Impacted by Technology: 1.4 quads (all vapor-compression cycles).

Performance Information/Data and Source:

Summary: Low-pressure refrigerant cycles yield a 5-10% efficiency gain over higher-pressure refrigerant cycles. The larger required flow rates require larger piping systems (including condenser and evaporator) and create complications in compressor selection and sizing (centrifugal compressors are better suited than reciprocating compressors). With low-

pressure refrigerants, the evaporator pressure is sub-atmospheric, so that any leakage draws air and moisture into the system. Purge systems are generally used to prevent air and moisture from accumulating in the system. As such, low-pressure refrigerants are best suited for large chiller applications.

Sand et al. (1997): The most efficient chillers available use R-123, with COPs up to 7.82 at ARI conditions. They estimate the following integrated part-load values, based upon then-current data, ARI members, and AGCC (see Table A-5).

Table A-5: Efficiency Comparison of R-123 to R-134a and R-123 (from Sand et al., 1997)

Centrifugal Chiller (kW/ton)	Y1996 (350/1000RT)	Y2005 (350/1000RT)
HCFC-22	0.59/0.54	0.53/0.48
HCFC-134a	0.56/0.54	0.52/0.48
HCFC-123	0.52/0.47	0.47/0.45

- 5% – 10% savings in efficiency results by using HCFC-123 versus high-pressure refrigerants.

Cost Information/Data and Source:

Summary: Centrifugal chillers have the compressor mounted on the shell of the evaporator, with a short, large diameter suction line to the compressor, minimizing the suction pressure loss. For other types of equipment, the refrigerant piping system, the condenser, the evaporator, and the compressor must all be larger in a low-pressure refrigerant system than in a higher-pressure refrigerant system. As such, the capital cost of a low-pressure air-conditioning system would be greater (no specific cost information available). Low-pressure refrigerant equipment would be expensive for lower-tonnage/smaller scale equipment because low-pressure cycles generally require larger evaporators and compressors to accommodate the (relatively) larger vapor volumes occurring at lower pressures (as well as the additional cost of a purge system). In the case of a packaged rooftop unit, a very space-constrained environment, larger equipment size would likely increase the size of the box and, hence, its cost. Moreover, lower pressure cycles tend to have higher compressor pressure ratios, which may require 2- or 3-stage compressors to operate.

Non-Energy Benefits of Technology: Maintaining low-pressure systems is perceived as safer than maintaining higher-pressure systems (further, associated safety codes and standards may be less intrusive if the operating pressures are low enough – a maximum high-side pressure of 15psig).

Notable Developers/Manufacturers of Technology: Carrier, Trane, and York all market large-scale low-pressure (HCFC-123) centrifugal chiller systems.

Peak Demand Reduction?: Yes.

Most Promising Opportunities for Technology, Location(s) and Application(s): Low-pressure refrigerants are best suited for large-scale centrifugal chiller equipment in buildings with large cooling loads (best opportunity for payback on capital cost of the equipment).

Perceived Barriers to Market Adoption of Technology: HCFC-123 (best suited to replace CFC-11 in chillers) is moderately toxic, so it has some associated safety concerns. First cost premium created by larger system components.

Technology “Next Steps”: Studies of low-pressure refrigerants other than HCFC-123 (HCFC-113 and HFC substitutes with similar boiling points, for example). Information about smaller-scale low-pressure systems (particularly in packaged/unitary equipment), including marginal quantitative performance/cost estimates.

References:

Sand, J.R., Fischer, S.K., and Baxter, V.D., 1997, “Energy and Global Warming Impacts of HFC Refrigerants and Emerging Technologies,” Report prepared by Oak Ridge National Laboratory for the Alternative Fluorocarbons Environmental Acceptability Study (AFEAS), U.S. Department of Energy.

Technology Option: Mass Customization of HVAC Equipment

Description of Technology: A mass customization design algorithm incorporates expert knowledge of how different design parameters impact equipment and system performance and cost, enabling the algorithm to develop and evaluate a very large number of virtual equipment designs, subject to the constraints of the design application. The algorithm outputs key information for the most-favorable options, including system first cost, expected operating cost, and size. In essence, the algorithm efficiently creates a custom product for the application (hence, *mass customization*). Upon generating an acceptable design, the algorithm can generate a full set of equipment drawings. In another manifestation that leverages existing parts, a mass customization algorithm develops an optimized equipment/system design based upon existing parts and options. Finally, an algorithm can link into supply chain management systems to create bills of materials (BOMs) and order parts. The HVAC industry has already started implementing mass customization for large air-handling units and chillers, where customers specify the features they want, and the manufacturer custom fabricates the unit using smart design software. It has not yet expanded into smaller HVAC equipment such as unitary products.

Description of How Technology Saves Energy: Mass customization does not inherently save energy. However, if customers wanted more efficient equipment for an application, they could order it at a lower cost than a one-of-a-kind piece of custom equipment because it would use standard parts to develop the lowest-cost design to achieve a given performance standard. Alternatively, manufacturers could specify that each piece of HVAC equipment is designed and built to achieve an optimized equipment performance for the intended application, reducing the energy consumption of the device. More likely, however, mass customization (as it has with large air-handling units and chillers) will improve equipment functionality and supply-chain management with minimal, if any, efficiency improvements.

Technology Technical Maturity: Current/New.

Systems/Equipment Impacted by Technology: All HVAC Equipment.

Readily Retrofit into Existing Equipment and Buildings: Not applicable.

Total Primary Energy Consumption by Systems/Equipment Impacted by Technology: 4.5 Quads (all HVAC).

Performance Information/Data and Source:

Summary: It is not clear that mass-customization will save energy. If, however, the process of selecting equipment shifts towards more-efficient designs as a result of mass-customization algorithms, it will save energy.

Dahl and Ochs (1997): A study sampled 100 pump selections made manually using the catalog pricebook, then re-selected them using a mass-customization algorithm. They found that 30% of the manual selections were “sub-optimal” such that another selection would have given superior performance or price.

Ley (2002): Large commercial chillers and air-handling units have already seen “a fair amount” of mass customization. So far the primary drivers for custom designs have been geometry and cost, based on customer demands. Higher efficiency could potentially be a driver if customers demanded it: “We have offered higher efficiency options in the past, but customers do not want them.” Sees a large potential for energy efficiency improvements in small unitary equipment, but is not certain whether mass customization is the best way to make the improvements because it would disrupt the economies of scale that currently exist.

Cost Information/Data and Source:

Summary: Mass-customization for HVAC equipment will tend to reduce costs of made-to-order equipment, but may actually increase the cost of cataloged equipment due to the initial investment to establish the mass customization capability (data entry, programming time, software de-bugging, etc.).

Dahl and Ochs (1997): Mass-customization results in cost reductions to manufacturers and distributors via improved quotation productivity, adherence to product standards, standardized proposal/order entry systems, and reduced publications costs (catalogs and pricebooks). The competitive market advantage created by a mass-customization system increases sales (38% increase over a two-year period for a pump manufacturer).

Ley (2002): Where equipment is already made-to-order a mass customization algorithm will cut costs and make the process more efficient, but for equipment that is traditionally “catalogued” (such as small unitary equipment) it would require significant initial investment by manufacturers and likely increase the per-unit cost of production.

Non-Energy Benefits of Technology: Could optimize functionality and supply-chain management. Improved customer satisfaction.

Notable Developers/Manufacturers of Technology: SDRC, Parametric Technologies, Heide Corporation.

Peak Demand Reduction?: Potentially, if the end user specifies peak condition energy efficiency as a key design goal.

Most Promising Opportunities for Technology, Location(s) and Application(s): Applications/buildings with unique design conditions; large unitary equipment; manufacturers with vertical integration (sales, manufacturing, and design) such as Lennox.

Perceived Barriers to Market Adoption of Technology: Requires a major up-front investment in development and implementation; Old sales and design system has momentum from years of “business as usual;” Sales force may require basic engineering training to properly guide the selection process.

Technology “Next Steps”: More detailed evaluation of potential cost and energy savings benefits, particularly for large unitary equipment.

References:

Dahl, T. and Ochs, J., 1997, “Preliminary Pump Selection and Configuration in an Engineered-to-Order Design Environment”, *Proc. ASME Fluids Engineering Division Summer Meeting: FEDSM’97*, June 22-26, #FEDSM97-3336.

Ley, T., 2002, Personal communication. The Trane Company, 10 April.

Technology Option: Microscale Heat Pipes

Description of Technology: Generally speaking, heat pipes use boiling processes to very effectively transfer heat between two regions, superior to that achieved by high conductivity metals (e.g., copper). A hermetically-sealed pipe, typically made of copper and outfitted with copper or aluminum fins, contains a substance selected such that the cold region condenses the gas-phase of the substance and the warm region evaporates the liquid-phase of the substance. Mass transfer of the vapor from the hot to cold region occurs via gas flow, while wicking material moves liquid from the cold region to the hot region via capillary action and/or gravity resulting in high heat transfer coefficients. Conventional heat pipes are used in HVAC for air-to-air sensible heat recovery (see “Air-to-Air Heat Exchangers and Enthalpy Wheels”) and to pre-cool before and re-heat air after an evaporator coil (see “Heat Pipes”). Microscale heat pipes differ from conventional heat pipes in that they have characteristic dimensions of less than 1.0mm, and often are constructed in flat or disc shapes, in contrast to cylindrical conventional heat pipes. These microscale heat pipes have emerged in electronics cooling and zero-gravity applications, but have not yet appeared in HVAC applications. For example, printed circuit boards or other electronic products may use flat heat pipes to effectively transfer heat from an intense, concentrated thermal source to a much larger heat sink.

Description of How Technology Saves Energy: Microscale heat pipes appear to have minimal application in HVAC equipment, as they are used in other applications when conduction cannot provide sufficient heat transfer and isolation of the cooled surface from a fluid (e.g., air) is essential.

Technology Technical Maturity: Advanced.

Systems/Equipment Impacted by Technology: All vapor compression cycles.

Readily Retrofit into Existing Equipment and Buildings: No.

Total Primary Energy Consumption by Systems/Equipment Impacted by Technology: 1.4 quads (all air-conditioning equipment and heat pumps).

Performance Information/Data and Source:

Summary: Due to their small characteristic dimensions and the limits of surface tension upon liquid flow, microscale heat pipes effectively transfer heat over short dimensions. Small-scale cooling applications (computer chips for example) use microscale heat pipes successfully, but larger-scale applications like HVAC are probably not well suited for microscale heat pipes.

Cao and Faghri (1994): Thermal engineers have employed micro and miniature heat pipes for cooling computer chips; however, they tend to be expensive and are also sensitive to performance impairment by non-condensable gases. Furthermore, many micro-heat pipes

perform poorly at lower temperatures (below ~50°C for water, with a characteristic heat pipe dimension of <0.1mm) because the heat pipe will approach the free molecular flow regime, resulting in much lower heat transfer coefficients. Thus, microscale micro heat pipes are likely not well-suited for many HVAC applications.

Cost Information/Data and Source:

Summary: Microscale heat pipes are expensive due to their rather complex design and manufacturing difficulty.

Cao and Faghri (1994): Micro-scale heat pumps tend to be expensive.

Reid (2001): Smaller scale (micro-, denoting <100s of microns, and mini-) heat pipes appear to provide little performance gains (b/c air-side heat transfer often dominates heat transfer resistance), but cost very much (intricate, multi-component, current technology manufacturing and performance optimized). Complex to design with heat pipes. One possible application would be as regenerators in acoustic cooling/refrigeration.

Non-Energy Benefits of Technology: Smaller heat exchangers. Lighter weight than solid heat exchangers.

Notable Developers/Manufacturers of Technology: NASA (Goddard, Lewis), Thermacore, Fujikura, Noren Products, Purdue University (Electronics Cooling Laboratory).

Peak Demand Reduction?: Yes; improved heat exchanger performance decreases energy consumption during peak demand periods.

Most Promising Opportunities for Technology, Location(s) and Application(s): Refrigerant-refrigerant heat exchangers (e.g., post-evaporator to post-condenser).

Perceived Barriers to Market Adoption of Technology: Expense; function on smaller scales than typically used in HVAC.

Technology “Next Steps”: Few apparent HVAC applications.

References:

Cao, Y. and Faghri, A., 1994, “Micro/Miniature Heat Pipes and Operating Limitations”, *Enhanced Heat Transfer*, vol. 1, no. 3, pp. 265-274.

Reid, R.S., 2001, Personal Communication, Los Alamos National Laboratory.

Technology Option: Modulating Boilers and Furnaces

Description of Technology: Modulating furnaces and boilers alter their heating output to maintain the set-point temperature by regulating how much fuel they burn (analogous to a variable-speed motor). While traditional furnaces turn on and off (cycle) when the thermostat temperature rises above or falls below the set-point by a certain threshold (ΔT), modulating units modulate their output to closely maintain the set-point temperature at any condition. Smaller boilers also cycle, typically to maintain the hot water or steam temperature within a specified temperature range, but modulating units modulate their thermal output to closely maintain the water or steam set-point temperature at any condition. Often, an electronic monitoring and control system modulates the cycle frequency and output of the furnace, taking into account both the current heating status and the past 5-20 heating cycles (some furnaces even monitor the outdoor and indoor temperatures to calculate the required system output). While dual-stage units (high-low settings) are standard equipment in commercial building applications, fully modulating equipment has limited market penetration.

Description of How Technology Saves Energy: Modulated firing of a furnace reduces furnace cycling losses and enables lower room set-point temperatures (traditional units must have a higher set-point to maintain a minimum thermal comfort temperature at the bottom of the cycling swing). A modulating boiler also reduces cycling losses. As most boilers or furnaces do not fire continuously due to heating loads (and equipment over-sizing), the reduction in cycling losses results in higher seasonal efficiencies and net annual energy savings. For furnaces, the lower set-point temperature reduces heat loss through the building envelope and reduces the overall energy consumption.

Technology Technical Maturity: Current.

Systems/Equipment Impacted by Technology: Oil and gas fired furnaces, boilers, unit heaters, and packaged units.

Readily Retrofit into Existing Equipment and Buildings: Yes.

Total Primary Energy Consumption by Systems/Equipment Impacted by Technology: 1.1 quads (all gas and oil heating); in practice, the relevant quantity of energy will be smaller, as many commercial furnaces and boilers already have two or more stages, which realize a majority of the energy benefits afforded by modulation.

Performance Information/Data and Source:

Summary: Modulating furnaces have higher seasonal efficiencies than conventional units by reducing cycling losses (~5% in seasonal efficiency, e.g., AFUE) and may reduce the set-point temperature by ~2°F required for thermal comfort, resulting in up to 8% in annual energy consumption by reducing envelope heat loss. Modulating boilers can realize ~7%

reduction in annual energy from reduced cycling as compared to a single-stage boiler; however, many boilers have multiple stages, relative to which a modulating boiler provides minimal efficiency gains. ASHRAE Standard 155 (in preparation) will provide a test method for evaluating the efficiency gains of multi-step and modulating steam and hot-water boilers.

ADL (2001; Internal Proposal to DOE): Relative to a single-speed “typical” furnace, modulation will result in a ~5% efficiency increase (from 80% to ~85%) by reducing cycling. The modulating furnace will also allow lower set-point temperatures (~2°F lower) because, unlike traditional furnaces, it does not need to account for the temperature swing associated with cycling. The set-point reduction results in ~8% of additional energy savings annually. The equipment sizes are also reduced (furnace/boiler and fan/blower) because of the heat loss reduction.

Weil-McLain (1991): A typical single-stage (on/off) boiler is 7% less efficient (seasonal efficiency) than a dual-stage boiler (low-high-low-off). A modulating boiler realized marginal (if any) efficiency improvement over the dual-stage boiler. Manufacturers offer modulating furnaces, but they are typically integrated into condensing furnace designs (for thermal comfort reasons, not added efficiency). Operation at part-loads results in condensation within the heat exchanger.

PATH (2002): A residential modulating (and condensing) furnace (60kBtu – 120kBtu) realizes ~4% AFUE improvement relative to a condensing furnace.

Cost Information/Data and Source:

Summary: Modulating units are significantly more expensive than single-stage and dual-stage units (two to three times more). The added cost comes from added valve cost (regulated/automated) and associated controls and the expensive stainless steel needed to protect the heat exchanger from condensation at lower heating levels.

Weil-McLain (1999): Oil systems typically modulate via a multi- (or variable-) speed pump. For power boiler-burner units over 20 hp (15kW, or 51,000 btu), dual-stage equipment is available at low cost. Even with power gas or gas-oil burners, the incremental cost is one-third to one-half that of modulated firing. Modulated firing is standard over 150 hp (380kBtu).

Nastro (2001): A 20-ton rooftop with a modulating furnace costs \$8,000-9,000 more than a 2-stage gas heating furnace. A 50-ton rooftop with a modulating furnace costs \$9,000-10,000 more. Note: The units cited have additional features besides a modulation furnace which tend to increase their cost, e.g., more sophisticated controls.

PATH (2002): A residential modulating (and condensing) furnace (60kBtu – 120kBtu) has a \$400 to \$800 cost premium relative to a single-stage condensing furnace.

ADL (2001); Internal Proposal to DOE): Residential designs may use a ~\$20-25 valve for single-stage, ~\$35 for two-stage, and a ~\$50 variable solenoid valve for modulation.

Non-Energy Benefits of Technology: Modulating furnaces can more precisely maintain internal temperatures, producing smaller temperature swings and improving occupant comfort.

Notable Developers/Manufacturers of Technology: York, Rheem, Carrier, Williamson, and Trane.

Peak Demand Reduction: No. Gas and oil fired equipment has minimal impact on peak electricity demand.

Most Promising Opportunities for Technology, Location(s) and Application(s): Cooler regions with high heating loads (the Midwest and Northeast for example), and buildings that require consistent internal temperatures, such as hospitals.

Perceived Barriers to Market Adoption of Technology: Modulating does not appear to offer much energy-savings benefit over dual-stage equipment, and dual-stage equipment is cheaper to implement than modulating design. Contractors balk at installing new, unproven product.

Technology “Next Steps”: Reduce cost of modulating furnaces. Promoting dual-stage equipment.

References:

ADL, 2000, “Energy Efficient Rooftop Air Conditioner: Continuation Application Technical Progress Statement”, Arthur D. Little, Inc. presentation dated November 7, 2000 for the U.S. Department of Energy, Project #: DE-FC26-99FT40640.

Nastro, T., 2000, Personal Communication, Trane Company.

PATH, 2002, “Path Technology Inventory – Modulating Furnace”, National Association of Home Builders web site, The Partnership for Advancing Technology in Housing (PATH), Last accessed June 25, 2002 at:
<http://www.nahbrc.org/tertiaryR.asp?TrackID=&DocumentID=2098&CategoryID=1310>.

Weil-McLain, 1991, “Energy Management with Commercial Hydronic Heating Systems”, **Engineers Reference Manual**, supplement to Section IV, published by the Weil-McLain Engineering Department.

Technology Option: Natural Refrigerants – Ammonia/CO₂/Water Refrigeration Cycles

Description of Technology: Natural refrigerants (ammonia, carbon dioxide, and water) have been used successfully for niche industrial applications, but each presents unique technical obstacles for widespread adoption in commercial air-conditioning systems. Recently, however, the commercial air-conditioning industry and air-conditioning research centers have revisited using natural refrigerants as substitutes for HCFCs, which are being phased out of production because of their stratospheric ozone depletion potential, and HFCs, which, though non-ozone depleting, are trace greenhouse gases.

Description of How Technology Saves Energy:

Refrigerant properties affect the COP of a vapor compression air conditioning system via thermodynamic and transport properties and the effect on the compressor efficiency. Depending on the evaporator and condenser temperatures, some natural refrigerants can exhibit better thermodynamic cycle performance (theoretical COP) than traditional HCFC and HFC refrigerants leading to more efficient air-conditioning equipment. The transport properties of some natural refrigerants result in higher boiling and condensing heat transfer coefficients than fluorocarbon refrigerants, potentially leading to reduced temperature lift and increased COP. Compressor efficiencies are affected incrementally by refrigerant properties, for example carbon dioxide requires less pressure ratio than other refrigerants, requiring less compression work. The potential efficiency increases are modest, on the order of 5%.

Technology Technical Maturity: Current

Systems/Equipment Impacted by Technology: All vapor-compression air-conditioning systems.

Readily Retrofit into Existing Equipment and Buildings: Yes. Typically, however, natural refrigerants cannot serve as “drop in” replacements for other refrigerants in existing vapor compression cycles.

Total Primary Energy Consumption by Systems/Equipment Impacted by Technology: 1.4 quads (all compressors).

Performance Information/Data and Source:

Summary (ammonia): Several studies show that ammonia air-conditioning systems have comparable performance as systems using traditional refrigerants, but ammonia is moderately toxic and flammable and reacts with copper so systems must be carefully engineered for safety and durability. The added safety precautions (using indirect heat transfer loops for example) decrease performance efficiency and increase complexity and cost.

Summary (CO₂): Studies indicate that CO₂ air-conditioning systems have somewhat lower performance efficiencies than systems using traditional refrigerants. CO₂ has some performance advantages in a heat pump in heating mode. CO₂ has a low critical temperature (~88°F), so air-conditioners must use it in a transcritical gas state (on the high-pressure side of the system) that requires higher pressures and more condenser area.

Summary (water): Water is unique because it serves as the refrigerant and the process fluid all in one loop, eliminating the need for an intermediate evaporator heat exchanger chilled water applications. Relative to conventional refrigerants, water has slightly lower theoretical efficiencies and much greater volumetric flow rates due to the low vapor pressures at operating conditions (0.2 – 2.0 psia). If water serves as the refrigerant and as the coolant (e.g., with a chilled water loop) and/or the heat rejection liquid (i.e., with a cooling tower), the overall system performance could exceed that of conventional refrigerant cycles due to the direct water-to-water heat exchange. With the evaporator and condenser both operating well below atmospheric pressure, systems would need to purge non-condensables (air leaks into the system, dissolved air picked up in the water in the cooling tower).

Sand et al. (1997):

Ammonia: Ammonia is a poor match for unitary equipment because existing equipment production relies heavily on copper (tubing, motors, etc.) with which ammonia reacts negatively. Available ammonia screw chillers claim higher COPs than HFC-134a chillers in the European market, and similar COPs as HCFC-22 chillers. Secondary heat transfer loops are required for safety (since ammonia is toxic), so the use of ammonia is limited to chiller applications.

CO₂: Carbon dioxide has a low critical temperature (87.76°F), so for most air conditioning applications it operates in the transcritical regime (which is inherently less efficient than vapor cycles operating comfortably below the critical temperature).

IIR (1998, p.271): Carbon dioxide has high volumetric efficiency (due to high operating pressures in vapor-compression cycles) and good heat transfer properties. Compared with HCFC-22 heat pump systems carbon dioxide system led to 3-14% improvement in heating mode and 0.5-14% decrease in cooling mode (though the evaporator and condenser surface areas for the carbon dioxide system was about twice that of the HCFC-22 system).

IIR (1998): Numerous authors noted that, theoretically, carbon dioxide should be less effective than other cycles.

IIR (1998, pp. 297-302): Work by Purdue University (Groll) for the Army Environmental Control Unit showed that an energy recovery turbine serving as the expansion valve could cause the COP of a carbon dioxide air-conditioning system to meet or exceed HCFC-22 performance.

IIR (1998, p.93): Water as a refrigerant requires large volumetric flow rates because of very low pressures under operating conditions (6-50mbar), which also leads to high pressure ratios; used in South African mines to produce triple point ice for cooling.

Brasz (1999): A cycle analysis assuming realistic motor and compressor efficiencies for several refrigerants operating in a centrifugal chiller showed that water has a COP 5-10% less than other refrigerants.

Fischer and Labinov (1999): Compared to a heat pump using R-22, the heating system COP is 3 to 15% lower, the cooling system COP 20 to 30% lower.

ACHRN (2000): In tests comparing the COPs of air-conditioner systems, approximately 90% of the cases revealed slightly better performance of CO₂ versus HC refrigerants.

Cost Information/Data and Source:

Summary: While the cost of natural refrigerants is quite small (compared with HCFC-22 and HFC-404A, ammonia is about 1/10th the cost, carbon dioxide is about 1/100th the cost; water is ~free), the equipment cost for natural refrigerant systems tends to be substantially greater than that of conventional commercial air-conditioning equipment due to safety concerns (Ammonia), higher pressures (CO₂), and very large vapor volumes (H₂O).

CERN (2001): Water refrigerant air-conditioning equipment is about twice as expensive as conventional equipment because of equipment complexity and scale (multi-stage compressors and direct-contact evaporator).

Concepts ETI (2000): Their investigation of compressor designs using water revealed that, for a centrifugal compressor, a two-stage design offered superior performance relative to a one-stage design, while a *seven-stage* design offered the best efficiency for an axial compressor.

Pearson (2001): In UK, ammonia ~\$1.46/kg, CO₂ ~1/10th of ammonia, and R-22 and R-404A ~10 times ammonia.

Non-Energy Benefits of Technology: The major benefit of natural refrigerants is that they have a much smaller direct global warming potential than do CFC, HCFC, and HFC refrigerants. The indirect impact, however, will counteract the direct benefits if air-conditioning systems are less efficient with natural refrigerants.

Notable Developers/Manufacturers of Technology: Major developers and manufacturers are focussed in Europe and Asia. INTEGRAL Energietechnik GmbH in Denmark is developing technologies to use natural refrigerants. SINTEF in Norway has focussed on applying CO₂ to a range of cooling equipment applications. Purdue University, the University of Illinois, and the University of Maryland have research programs looking at

natural refrigerants. The LEGO factory in Billund, Denmark has a water refrigerant chiller developed by the Danish Technological Institute.

Peak Demand Reduction: No.

Most Promising Opportunities for Technology, Location(s) and Application(s):

Natural refrigerants are best suited for chiller applications, not unitary systems. (Sand et al., 1997)

Perceived Barriers to Market Adoption of Technology: The cost of equipment modifications to bring natural refrigerant vapor-compression systems to acceptable standards for commercial air-conditioning is significant. Ammonia systems must be engineered for safety since ammonia is toxic and flammable (and reacts negatively with copper), carbon dioxide systems require high-pressure piping in the condenser and suffer from low CO₂-conventional oil miscibility (Fischer and Labinov, 1999), and water systems require multi-stage compressors and large-capacity piping.

Technology “Next Steps”: Consideration of the additional costs of systems using natural refrigerants. ARI (2002) plans fund a research project “Use of Water Vapor as a Refrigerant: Part II – Cycle Modification and System Impacts on Commercial Feasibility”, in Y2002.

References:

Aarlien, R. and Frivik, P.E., 1998, “Comparison of Practical Performance Between CO₂ and R-22 Reversible Heat Pumps for Residential-Use”, *Natural Working Fluids – IIR Gustav Lorentzen Conference Proceedings*, Oslo, Norway, 2-5 June, International Institute of Refrigeration, pp. 388-398.

ARI, 2002, “21-CR Releases Three Projects”, *Koldfax*, January, p.4.

Brasz, J.J., 1999, “Centrifugal Compressor Design Choices for Chillers”, *ImechE*, Paper #C542/057/99.

CERN, 2001, “New Age Water Chillers with Water as Refrigerant”, CERN on-line publication. CERN – European Organization for Nuclear Research, downloaded from <http://st-div.web.cern.ch/st-div/st98ws/technology/JacekK.pdf> on December 7, 2001.

Concepts ETI, 2000, “The Efficiency Limits of Water Vapor Compressors Suitable for Air-Conditioning Applications”, Final Report Prepared by Concepts ETI, Inc., for the Air-Conditioning and Refrigeration Technology Institute, Project 605-10010, November. Available at: <http://www.arti-21cr.org/research/completed/finalreports/10010-final.pdf> .

Fischer, S. and S. Labinov, 1999, "Not-In-Kind Technologies for Residential and Commercial Unitary Equipment", Oak Ridge National Laboratory Report, ORNL/CON-477, December.

IIR, 1998, "Natural Working Fluids – IIR Gustav Lorentzen Conference Proceedings", Oslo, Norway, June 2-5, International Institute of Refrigeration.

Pearson, A., 2001, "New Developments in Industrial Refrigeration", *ASHRAE Journal*, March, pp. 54-59.

Sand, J.R., Fischer, S.K., and Baxter, V.D., 1997, "Energy and Global Warming Impacts of HFC Refrigerants and Emerging Technologies", Alternative Fluorocarbons Environmental Acceptability Study (AFEAS), U.S. Department of Energy.

Technology Option: Phase Change Insulation/Ceiling

Description of Technology: The material incorporates a material that changes phase at a temperature comfortable to the occupants, which tends to mitigate large swings in temperature. In effect, the material acts as a very large thermal reservoir. The University of Dayton Research Institute has carried out research using K-18, a paraffin-based phase-change material consisting of mostly octadecane, which has a solid-liquid change temperature of $\sim 26^{\circ}\text{C}$ (Kissock, 2000a). To date, this material has been used in pizza delivery containers, clothing, and telecom batteries applications. In building applications, Huff (2000) indicates that research has concentrated on gypsum board imbued with PCMs, but that floor tiles, ceiling tiles, particle board, foam insulation board (i.e., virtually any porous material) have also been investigated and can contain PCMs. Kissock (2000b) reports on the use 10% PCM (K-18) imbued into concrete.

Description of How Technology Saves Energy: By virtue of its very high heat capacity (caused by the latent heat of the phase change material), phase change insulation moderates temperature swings, reducing the required amount of heating and cooling. Similarly, it also could reduce the ventilation air volume required to deliver heating and cooling in all-air systems (above and beyond IAQ requirements). PCMs realize greater savings in buildings with low thermal masses than those with higher thermal masses, i.e., they have a much greater impact on a mobile home than a frame house than a concrete-wall building.

Technology Technical Maturity: New/Advanced.

Systems/Equipment Impacted by Technology: Heating and cooling, heating-cooling related ventilation

Readily Retrofit into Existing Equipment and Buildings: No; requires retrofitting of material into building materials (e.g., gypsum board, concrete).

Total Primary Energy Consumption by Systems/Equipment Impacted by Technology: 4.7 quads.

Performance Information/Data and Source:

Summary: The influence of PCMs on building load varies greatly between building types, that is, they have a greater impact in buildings of light construction, e.g., frame buildings. Climate also has a strong influence on PCM energy savings, as moderate climates where the temperature passes through the PCM transition temperature often (particularly at night) will realize greater savings than climates that remain predominantly above or below the transition temperature. Simulations suggest reductions of no more than 5% in cooling energy and negligible reductions in heating loads for most commercial buildings in Northern climates because of their existing thermal mass (e.g., for concrete and/or masonry construction).

Kissock (2000b): Simulations of the influence of the PCM K-18⁹⁸ (but with a phase transition temperature of ~21°C) on building component loads and total residential loads for the climate of Dayton, OH showed negligible reductions in annual heating loads, but appreciable annual cooling load reductions (see Table A-6).

Table A-6: PCM Influence of PCM-Imbided Building Components on Peak and Annual Loads *Passing Through That Component* (from Kissock, 2000b)

Component	Peak Cooling Load Reduction [%]	Annual Cooling Load Reduction [%]	Peak Heating Load Reduction [%]	Annual Heating Load Reduction [%]
Concrete Wall:10% Imbided PCM vs. 0% PCM	19%	13%	11%	1%
Steel Roof: 28% Imbided PCM Gypsum Board	30% ⁹⁹	14%	3%	3%
Frame Wall: 29% Imbided PCM Gypsum Board	16%	9%	1%	0%
Frame House: 29% Imbided PCM Gypsum Board ¹⁰⁰	5%	4%	2%	1%

Kissock (2000a): Performance benefits in concrete buildings do not appear to be substantial (due to existing thermal mass); people looking into ways of imbiding more PCM in building materials, 10% appears to be the limit for paraffin PCMs, alcohol-based might go higher.

Cost Information/Data and Source:

Summary: PCM materials cost ~\$2 per pound, while wall board imbided with PCM has a cost premium on the order of \$1.50/ft² (for a residence). Under optimistic assumptions, PCMs applied in a small commercial building have simple payback periods ~30 years, not including any reduction in equipment capacity due to reduced peak A/C demand.

Kissock (1998): Paraffin-based PCM with melting temperatures near room temperatures go for ~\$2 per pound (Fieback and Gutberlet, 1998).

Huff (2000): Estimates the cost premium for a typical ~2,000 ft² residence of ~\$2-4k for PCM wall board (frame house).

Kissock (1998): Manufacturing of wall board imbided with PCM is not inexpensive because the imbiding process requires ~24 hours at temperature (~52°C) (from Salyer and Sircar, 1989).

⁹⁸ According to DOE, K-18, is a low-cost alkyl hydrocarbon blend that melts and freezes congruently at 25°C (77°F). <http://www.eren.doe.gov/consumerinfo/refbriefs/b103.html>.

⁹⁹ Additional insulation with the steel roof *sans* PCM (equivalent to another layer of iso-board, i.e., to make 3 versus 2 layers) decreased peak heating and cooling loads by 31%; that is, insulation was more effective than PCM for the steel roof scenario.

¹⁰⁰ In a “Night flushing” scenario, i.e., ventilating the interior space at night with cooler air to liberate heat from the PCM, realizes approximately a 17% annual cooling load and 6% peak cooling load reductions.

TIAX Calculations: An upper-bound calculation was performed to explore the applicability of PCMs, using several assumptions. First, PCM costs \$2/pound imbibed into wall board (i.e., no additional cost beyond material). Second, the PCM cycles through a complete melting/solidification cycle 100 days a year. Third, the wallboard imbibed to 28% mass K-18 has a heat of fusion of 26Btu/pound (estimated from Kissock et al., 1998), with an overall density of 0.52 pounds/ft². Fourth, the 5,000ft² commercial building has a square shape with 10-foot wallboard height, i.e., a total area of 2830 ft² (mass ~1,470 pounds). Fifth, the PCM wallboard displaces 10 SEER air conditioning using electricity priced at \$0.07/kW-h. Under these assumptions, the PCM wallboard has an incremental cost of ~\$825 and displaces ~3,800kBtu per year to reduce cooling energy consumption by ~\$27 per year. In sum, this simplified calculation suggest a simple payback period of ~30 years. Considering the expense to imbibe the PCM into the wallboard would tend to increase the payback period, as would decreasing the number of days that the PCM changes phase. Higher electricity rates, a greater number of days that the PCM changes phase, and considering any decrease in initial equipment size would decrease the simple payback period.

Non-Energy Benefits of Technology: Smaller temperature swings enhance comfort. Reductions in peak loads can allow down-sizing of cooling equipment.

Notable Developers/Manufacturers of Technology: Phase Change Laboratories (pizza carriers, clothes, etc.). University of Dayton Research Institute (holds at least 16 patents on phase change materials); Schumann Sasol (Rubitherm subsidiary, in Hamburg, Germany) manufactures a range of PCMs for under-floor heating, heating (hot storage, often from solar) (<http://www.rubitherm.com/>). Matsushita has examined using PCMs as part of a floor-heating system.

Peak Demand Reduction?: Yes. PCMs can delay the onset of peak (sensible) cooling loads by several hours (Kissock, 2000b), e.g., Neeper (1990, from Kissock, 2000b), noted potential for shifting of more than 90% of peak load to off-peak periods. PCMs can also appreciably decrease peak loads in intermittently occupied spaces (e.g., theatres, schools, conference rooms, etc.) where loads normally fluctuate greatly.

Most Promising Opportunities for Technology, Location(s) and Application(s): Climates with large diurnal temperature swings; climates with moderate heating and cooling loads. In combination with night purging (passing cooler night air over the PCM-laden materials to cool the PCM below transition temperature), to build up “cooling reservoir” overnight.

Perceived Barriers to Market Adoption of Technology: First cost; unknown to contractors. Flammability issues will likely require fire retardant to pass fire codes for gypsum board concentrations used (~28% of total imbibed board mass typical; above ~20%, flammability increases dramatically, (Kissock et al., 1998). Upward creep in phase change material of ~3°C over a 10+ year period (Kissock et al., 1998). Possible material strength

concerns, e.g., for concrete imbibing, concrete keeps same strength properties to at least 5% PCM by mass (Sircar, from Kissock, 2000b). K-18 tested showed transition temperature range of ~8.3C, which could be improved by improving purity, but cost an issue (Kissock et al., 1998).

Technology “Next Steps”: Larger-scale testing; simulations for commercial buildings in a range of climates; materials to overcome fire issues; cost reduction of PCM-imbibed materials.

References:

Huff, L., 2000, Personal Communication, Energy Storage Technologies.

Kissock, J.K., Hannig, J.M., Whitney, T.I. and Drake, M.L., 1998, “Testing and Simulation of Phase Change Wallboard for Thermal Storage in Buildings”, *Proceedings of the ASME International Solar Energy Conference*, Albuquerque, NM, June.

Kissock, J.K., 2000a, Personal Communication, University of Dayton.

Kissock, J.K., 2000b, “Thermal Load Reduction from Phase-Change Building Components in Temperature Controlled Buildings”, *Solar Engineering 2000: Proceedings of the ASME International Solar Energy Conference*, Madison, W.

Technology Option: Refrigerant Additives to Enhance Heat Transfer

Description of Technology: A relatively small quantity of liquid solutions is added to the refrigerants, with the intent of improving heat transfer between the refrigerant and the evaporator/condenser. In one example, an a-olefin molecule polarized refrigerant oil additive (PROA) is added in a quantity equal to 5% of the volume of refrigeration oil.

Description of How Technology Saves Energy: Refrigerant additive manufacturers claim that highly polarized PROA molecules preferentially coat metal surfaces, forming a very thin (~molecular thickness) layer on the refrigerant-side heat transfer surfaces, displacing oils and other surface deposits. In theory, by cleaning the surface and establishing a very thin surface layer, PROA improves the surface heat transfer, particularly in older devices where surface build-up has reduced heat transfer efficacy.

Technology Technical Maturity: Current/Advanced. Some absorption chillers use refrigerant additives to increase heat transfer on falling-film absorbers.

Systems/Equipment Impacted by Technology: All vapor compression cycles.

Readily Retrofit into Existing Equipment and Buildings: Yes.

Total Primary Energy Consumption by Systems/Equipment Impacted by Technology: 1.4 (all vapor compression cycles; not absorption chillers).

Performance Information/Data and Source:

Summary: Claims for efficiency gains from refrigerant additives are very controversial, with FEMP (1997) and manufacturers (e.g., Polarshield) claiming significant gains. On the other hand, independent testing of a PROA additive performed by Florida Power & Light and ORNL indicated no significant effect.

Polarshield (2002): Product information for their PROA additive suggests that a 5-20% reduction in energy use is typical.

Grzyll and Scaringe (1997): The additive (chemical classification or composition unspecified) produced around a 5 to 8% cycle efficiency gains in heat pump testing, depending on the condenser temperature and additive concentration.

FEMP (1997): With PROA additives, a 3-7% efficiency increase “often” occurs”, increasing to 10-30% in five or more years older. Notably, larger compressors show gains at the lower end of the range because they are better maintained. However, FEMP notes that in “only one case was it clear that weather variability (cooling load) during the study period was considered”, calling the magnitude of savings into doubt. Similarly, FEMP notes that laboratory testing at Oak Ridge National Laboratory (ORNL) decreased energy consumption by less than 2%.

Whiting (2000): “An independent study for Florida Power & Light of a PROA additive indicated no significant effect.”

Cost Information/Data and Source:

FEMP (1997): PROA product ranges from \$25 to \$50 per ounce (\$0.845/ml to \$0.690/ml) (PROA), plus installation costs – FEMP mentions 15 minutes to an hour, depending on the amount of effort required). Will require additional labor for return visits for second treatment (if needed) and to clean filters and traps.

Johnstone (2002): Qwikboost costs \$26.43 for 4 fluid ounces.

Non-Energy Benefits of Technology:

FEMP (1997): Increased lubricity of refrigerant oil (no percentage given) to reduce mechanical friction and compressor wear.

Polarshield (2001): Product information for their PROA additive suggests that a 5-20% reduction in maintenance costs is typical.

Notable Developers/Manufacturers of Technology: Qwik. Polarshield.

Peak Demand Reduction?: UNCLEAR.

Most Promising Opportunities for Technology, Location(s) and Application(s): Older, neglected air-conditioning with a wide range of operating conditions.

Perceived Barriers to Market Adoption of Technology: Doubts about actual performance gains. Using additives could void the chiller manufacturer’s warranty, as the manufacturer claim that they cannot be responsible for the behavior of any post-market additives added to their compressors.

Technology “Next Steps”: Development of effective additives; demonstration of actual gains.

References:

FEMP, 1997, “Polarized Refrigerant Oil Additive – Technology for Improving Compressor and Heat Exchanger Efficiency”, *Federal Technology Alert*, last accessed at: <http://www.compresscare.com/femp.htm> .

Grzyll L.R. and Scaringe, R.P., 1997, “The Development of a Performance-Enhancing Additive For Vapor-Compression Heat Pumps”, *Thirty-Second Intersociety Energy Conversion Engineering Conference*, July 27 – August 1, Honolulu, Hawaii, Paper Number 97193.

Johnstone, 2002, Personal Communication, Johnstone Supply, March, 2002.
Polar Shield, 2002, Product Information, last accessed on March 6, 2002 at:
<http://www.polarshield.com/index.htm> .

Qwik, 2002, Product Information, last accessed on March 6, 2002 at:
http://www.qwik.com/q_presslinks.html .

Whiting, G., 2000, Personal Communication, Florida Power & Light Company.

Technology Option: Regular Maintenance

Description of Technology: Almost all HVAC systems and equipment have some specifications for regular maintenance activities. However, many (perhaps most) building operators do not carry out regular maintenance, neglecting it because of the cost and a lack of time. For instance, one HVAC system designer noted that varying degrees of neglect appears to be the rule for maintenance activities (Coggins, 2000). Some operators do diagnose maintenance-related problems; however, other activities may have higher priority for maintenance personnel. Ironically, maintenance activities rank among the most fruitful activities for ESCOs, with payback periods often on the order of one year or less. The regular maintenance option describes the energy savings available if building operators carried out maintenance as specified instead of sporadically. A recent trend is to take advantage of device networking to monitor key equipment performance metrics (power use, temperatures, etc.). Ultimately, this would enable the performance of maintenance as needed.

Description of How Technology Saves Energy: By identifying common problems, and replacing and/or maintaining equipment of a regular schedule, maintenance crews can watch for typical failures (blown fuses, dead sensors, dirty filters, etc), and prevent larger ones (blocked evaporator coils, cracked heat exchangers, bad compressors) to save energy by alleviating inefficient equipment or system operation.

Technology Technical Maturity: Current.

Systems/Equipment Impacted by Technology: All HVAC components and Systems.

Readily Retrofit into Existing Equipment and Buildings: Yes.

Total Primary Energy Consumption by Systems/Equipment Impacted by Technology: 4.5 Q. Survey of HVAC professionals in Modera et al. (1999) identified regular maintenance as the most common measure to improve air distribution system efficiency.

Performance Information/Data and Source:

Summary: The gains from regular maintenance vary widely depending upon the equipment type and specific measure taken. Evaporator coil cleanings appear to have a very favorable savings (<1 year payback period). This area requires more thorough study of the prevalence of problems, their degree, and savings magnitude and maintenance expense (e.g., what is the approximate distribution of coil fouling and its impact on energy consumption, what are the savings achievable from maintenance on a given schedule, how much does it cost to clean *all* coils on that schedule). A major problem with using maintenance surveys to estimate simple payback periods for regular maintenance is that they are “one-shot” activities; presumably, regular maintenance will decrease the benefit of performing regular maintenance by decreasing the efficiency gains realized by regular maintenance.

Breuker and Braun (1998): Evaluation of packaged rooftop units revealed that the most common failures involve electrical components (76%), mechanical components (19%) and the refrigeration circuit (5%). Of electrical, 87% occur in motor windings, and nearly all mechanical failures were in compressor valves, bearings, or connecting rods.

Piette (2001): The energy savings potential of regular maintenance is not known; a good area for study.

Breuker et al. (2000): They present data for unitary HVAC units that show how refrigerant leakage, liquid line restriction, compressor valve leakage, and condenser and evaporator fouling impact energy consumption. However, they note the dearth of information relating actual field maintenance practices to energy consumption: "More work is needed to document the energy penalties and reduced life associated with minimal maintenance practices".

Houghton (1997): Field studies in Mississippi found two 9.0 EER A/C operating at 6.6 and 7.1; study in Connecticut found 8.7EER rated units at 6.6 and 8.6. In LA, complete professional tune ups of 23 A/Cs in motels, restaurants, grocery stores yielded 22-42% efficiency improvements – 87% of units needed evaporator coil cleanings. Cited another study: 13 rooftop units in small commercial buildings found all had improperly operating OA dampers – servicing would cost ~\$10-20/each. Another survey: 18 units, 25 refrigerant circuits: 40% overcharged, 32% undercharged. Estimate: if dirty condenser coil increases condensing temperature from 95 to 105F, 16% decrease in energy efficiency would result; ~\$50 to clean condenser with power wash.

Breuker and Braun (1998): Summarize tested capacity and performance (COP) degradation for common rooftop unit faults, by degree of fault: low charge, liquid line restriction, compressor valve leakage, condenser and evaporator fouling (a 4 to 18% decrease for 14-56% blockage of condenser; 6 to 17% for a 12 to 36% blockage of evaporator).

Braun (2000, personal communication): Most people do not maintain their HVAC systems, because of cost, but larger organizations tend to carry out more regular maintenance, often via contracts. Cost-benefit analysis not known, very important to do and to know condition of stock.

Chapman (2001): Estimates ~\$0.21/ft² in annual O&M savings from Cybernetic Building Systems (CBS); energy savings unclear.

Cler et al. (1997, page 215, from Hewett et al, 1992): A utility performed "tune-ups" for 18 unitary cooling systems, with 4-15 tons capacity, 4-20 years old, in particular emphasizing correct charge, proper airflow, better heat transfer, major duct leaks. They achieved an average energy savings of 11% (annual), and 0.43kW demand reduction, saving ~\$390/unit/year for a cost of \$1,158/unit => ~3 year pay back. However, the *median* payback exceeded 6 years. E-Source believes most effective measures to be (from Houghton, 1997): cleaning condenser coils (cost ~\$50, savings ~\$200/year); reduce access

panel leakage by replacing missing screws (~\$100/year savings), servicing dampers; proper charging is uncommon, but the prevalence and field energy impact is not clear.

Energy Design Resources (2001): A 1997 PECEI survey of 60 commercial buildings found that over half suffered from control problems, 40% had HVAC system problems, and 1/3rd had improperly operating sensors. 15% missing components, ~25% had improperly functioning BEMSs, VSDs, or economizers.

Fryer (1997): In one case, an automatic tube-cleaning system for a chiller reduced the fouling factor from 0.0018 to 0.0002, reducing energy consumption by 17%.

OIT (1998): For fans, Tightening belts, cleaning fans, and changing filters regularly can each result in 2-5% savings.

Goswami et al. (2001): Laboratory testing showed that a 3-ton (residential) A/C unit functions fine at 90% charge, but performance drops off at 85% (15% degradation) and fails to deliver any cooling at 50% charge. Random surveys of 22 residential and commercial A/C units in Florida revealed that 17 (~77%) had charge levels of 85% or less. Re-charging the systems would cost ~\$130.

Cost Information/Data and Source:

Summary: Regular maintenance costs vary greatly with equipment type.

ASHRAE Handbook, 1999: approximate cost of maintenance (\$/ft²), based upon 1986 paper with adjustments for system types; may lose some validity for more recent equipment; base rate of \$3.59/m² of floor area, in 1983 dollars, \$6.00 in 1999 dollars¹⁰¹, or ~\$0.56/ft².

PG&E (2001): Comprehensive tune-ups have produced some positive results: A project that tackled 25 commercial rooftop units in New England brought 11 percent average energy savings, with paybacks of slightly less than three years. A similar project in Louisiana – “complete professional tune-ups” of 23 air conditioners in motels, restaurants, and grocery stores – brought efficiency improvements ranging from 22 to 42 percent. Paybacks were six months or less, largely because of the low cost of the tune-ups (\$118 to \$225 in 1992 dollars; estimate ~10 tons/unit, 400ft²/Ton = ~\$0.05/ft²).

Fryer (1997): Automatic tube-cleaning system for “typical” 500-ton chiller adds \$10-15k in first cost.

Non-Energy Benefits of Technology: Regular maintenance keeps equipment running smoothly and increases system reliability, decreasing down time and reducing repair expenses. Extends equipment life.

¹⁰¹ Dismal Economist CPI Calculator, http://www.dismal.com/toolbox/cpi_index.stm.

Notable Developers/Manufacturers of Technology: Utilities have funded studies in past. ASHRAE Guideline 4 (1993) recommends documentation practices for operations and maintenance.

Most Promising Opportunities for Technology, Location(s) and Application(s):

Systems receiving minimum maintenance at present, e.g., many packaged rooftop units. Turpin (2002) reports that many rooftop manufacturers have begun to design maintenance-friendly units, as well as simple diagnostics to alert operators to the need for maintenance.

Perceived Barriers to Market Adoption of Technology: Cost of maintenance, other priorities for maintenance personnel.

Perceived Best “Next Steps” for Technology: ESCOs ownership of HVAC (chauffage model) would create greater incentive for manufacturer/ESCO to maintain product (*if* cost effective). Utilities have developed programs to promote regular maintenance, e.g., New Jersey’s Energy Efficient Commercial & Industrial Construction Program offers Commercial & Industrial Building Operation & Maintenance Program featuring building operator training and certification to promote efficient building O&M practices (http://www.njcleanenergy.com/html/comm_industrial/bom.html). This would enhance diffusion of this practice. Remote diagnostics would improve economics by identifying equipment with greatest need for maintenance, possibly allowing for optimized maintenance schedules. These recommendations are similar to those advocated by Nadel et al. (2000) for increasing maintenance in the residential HVAC market (i.e., modest consumer incentives for system evaluation and treatment, direct marketing of the benefits to end-users and HVAC contractors, and providing diagnostic software to contractors, along with training on how to effectively use the software).

Siegel (2001) notes that the new ASHRAE 62 slated for adoption (in Y2002) includes section 62m that will specify ventilation system maintenance “more than once or twice a year”.

References:

ASHRAE, 1999, “Owning and Operating Costs”, Chapter 35 of the **1999 ASHRAE Applications Handbook**, ASHRAE Press : Atlanta, Georgia; data from Fohrmann and Alereza (1986).

ASHRAE, 1993, “Guideline 4 – Preparation of Operating and Maintenance Documentation for Building Systems”, ASHRAE Press: Atlanta, Georgia.

Breuker, M.S. and Braun, J.E., 1998, “Common Faults and Their Impacts for Rooftop Air Conditioners”, *International Journal of HVAC&R Research*, vol. 4, no. 3, pp. 303-316.

Breuker, M., Rossi, T., Braun, J., 2000, “Smart Maintenance for Rooftop Units”, *ASHRAE Journal*, November, pp. 41-47.

CEE, 2001, "Guidelines for Energy-Efficient Commercial Unitary HVAC Systems", Final Report, Prepared for the Consortium for Energy Efficiency, January. Available at: http://www.cceformt.org/com/hecac/Com_HVAC_spec.pdf .

Cler, G. et al., 1997, **Commercial Space Cooling and Air Handling: Technology Atlas**. E Source, Inc.

Energy Design Resources, 2001, "Design Brief: Energy Management Systems." Brief not dated; Downloaded February, 2001, from: http://www.energydesignresources.com/publications/design_briefs/pdfs/energyman.pdf .

Fryer, L., 1997, "Electric Chiller Buyer's Guide: Water-Cooled Centrifugal and Rotary Screw Chillers", E-Source Tech Update, TU-97-7.

Goswami, D. Y., G. Ek, M. Leung, C. K. Jotshi, S. A. Sherif, F. Colacino, 2001, "Effect of Refrigerant Charge on the Performance of Air Conditioning Systems", *International Journal of Energy Research*, Volume 25, Issue 8, pp. 741-750.

Houghton, D., 1997, "Operating and Maintaining Rooftop Air Conditioners", *ASHRAE Journal*, December, pp. 50-54.

Nadel, S., Gordon, F., and Neme, C., 2000, "Using Targeted Energy Efficiency Programs to Reduce Peak Electrical Demand and Address Electric System Reliability Problems", ACEEE Report No, U008, November.

OIT, 1998, "United States Industrial Motor Systems Market Opportunities Assessment", Prepared for the U.S. Department of Energy's Office of Industrial Technologies and Oak Ridge National Laboratory by Xenergy, Inc.

PG&E, 2001, "Packaged HVAC Equipment Guide", Downloaded from: http://www.pge.com/003_save_energy/003b_bus/003b1d8a8_hvac.shtml .

Piette, 2001, Personal Communication, Lawrence Berkeley National Laboratory.

Siegel, J.J., 2002, "There are Changes in the Air", *ACHRNews*, 24 December, pp. 1, 9.

Turpin, 2002, "Maintenance is the Key to Rooftop Longevity", *Air Conditioning, Heating & Refrigeration News*, 24 June, pp. 22-24.

Additional Sources:

ASHRAE TC4.11: Looking into funding project to determine the rate of faults in rooftop units, including efficiency degradation.

Strom, P. 2000, "Ongoing Commissioning and Preventative Maintenance", Presented at the 2000 National Conference on Building Commissioning.

Technology Option: Twin-Single Compressors

Description of Technology: Twin-single compressors are reciprocating compressors that have two (or more) compression pistons. When the cooling demand indicates partial loading, a control unit strategically de-activates one (or more) of the pistons, effectively creating a dual-(or multi-) capacity compressor. Specifically, a special crankshaft design that engages both compressor pistons at full load, reverses direction at partial load to engage only one compressor piston. Bristol (2001) mentions that each piston can be calibrated for 40/100% split to 60/100% split.

Description of How Technology Saves Energy: The two-piston design enables twin-single compressors to better meet partial compressor loads, thus resulting in superior SEER ratings relative to standard reciprocating compressors by reducing evaporator and condenser coil loading and cycling losses. The Bristol twin-single compressor motor is designed to provide near-peak efficiency at both full and half load.

Technology Technical Maturity: Current.

Systems/Equipment Impacted by Technology: All vapor compression cycles under 10 tons capacity.

Readily Retrofit into Existing Equipment and Buildings: No. Custance (2001) notes that retrofit of the compressor into existing equipment are very difficult, as condenser unit as well as blowers and controls must be replaced.

Total Primary Energy Consumption by Systems/Equipment Impacted by Technology: 0.35 quads¹⁰². According to Custance (2001), twin-single compressors are currently only used in residential systems in the US (1.5-5 tons). Larger packaged rooftop units (10+ tons) likely use more than one compressor (CEE, 2001), minimizing the benefit (and application) of a twin-single compressor in that product class.

Performance Information:

Summary: A twin-single compressor can realize at least a 20% improvement in SEER, resulting in similar annual energy savings.

Federal Register (1999): Can increase central A/C and HP from 10 to 12 SEER or from 12 to 14 SEER. With a variable-speed indoor blower, SEER can increase from 10 to 14 SEER

Bristol (2001): Performance calculations show savings of up to 25%.

¹⁰² Includes: RAC, PTACs, and unitary A/C and heat pumps between 5 and 10 tons. According to U.S. Census (2001), equipment in the 5- to 10-ton range account for roughly 26% of unitary air conditioning shipments (by tonnage) in 1999. Assuming that this percentage holds for the entire installed base of unitary equipment translates into ~0.19 quads (=0.26*0.75); applying a similar percentage to heat pumps adds an additional ~0.05 quads (=0.26*0.20).

ADL (2000): Use of one 5-ton TS compressor with a 10-ton unit reduces *total* annual energy consumption by 7.4% relative to a VAV system with two single speed 5-ton compressors (total reduction, to standard CAV system: 41%),

DOE (2000): Reverse engineering estimates for a 3-ton Split A/C with fancoil estimate that, for the same SEER, a twin-single compressor can realize the following cost savings, relative to steps taken to realize the same performance with conventional equipment (see Table A-7).

Table A-7: 3-ton Split A/C Unit Cost Impact of Twin-Single Compressor Relative to Conventional Equipment Options for Different SEER Values (from DOE, 2000)

SEER	TS % Cost Difference ("+" denotes cost increase)	Conventional Equipment Production Cost Estimate	TS Systems Production Cost Estimate	TS System Price Savings ¹⁰³ ("+" denotes price increase)
10	+	\$449	NA	NA
11	+	\$519	NA	+
12	+	\$563	NA	+
13	+	\$637	NA	+
14	-22%	\$815	\$636	\$378
15	-23%	\$893	\$688	\$410

Cost Information/Data and Source:

Summary: A twin-single 5-ton compressor has a cost premium in volume ~\$35 over a single-capacity compressor, with a payback period of about 2 to 3 years in commercial applications.

Custance (2001): For residential units, compressor costs: 1.5-3 tons range from \$140-155 per compressor. 3.5-5 tons range from \$185-220. A 10-seer system will have a ~\$30 premium. The crossover point is at 13-SEER where the costs are about equal or slightly less.

ADL (2000): Cost premium of 10-ton rooftop unit with one 5-ton conventional and one 5-ton TS compressor is ~\$35. Estimated payback is ~2.6-years¹⁰⁴.

Non-Energy Benefits of Technology: Improved partial load matching tends to reduce over-cooling (or, for a heat pump, over-heating) of spaces, improving occupant comfort. Decreasing the number of starts-and-stops reduces wear on compressor/motor, improving lifetime, e.g., Bristol (2001) predicts that it may reduce on/off cycling up to 75%. Lower noise during partial load operation. Combined with lower-speed blower motor operation, the twin-single compressor will extract more humidity.

Notable Developers/Manufacturers of Technology: Bristol.

¹⁰³ Using 2.0 "Mark-Up" for Incremental Changes.

¹⁰⁴ Cost of electricity decreased from \$0.076/kW-h to \$0.07/kW-h.

Peak Demand Reduction?: No. Custance (2001) notes that, on high-demand days, a utility theoretically could limit twin-single installations to only single-cylinder operation.

Most Promising Opportunities for Technology, Location(s) and Application(s):
Smaller (<10 tons) commercial HVAC installations.

Perceived Barriers to Market Adoption of Technology: First cost.

Technology “Next Steps”: Market promotion of comfort/SEER benefits. Voluntary market promotion program for commercial HVAC (e.g., beyond utility programs).

References:

ADL, 2000, “Energy Efficient Rooftop Air Conditioner: Continuation Application Technical Progress Statement”, Presentation on 7 November, Project #: DE-FC26-99FT40640.

Bristol, 2001, Information from Web Page. Available at: www.bristolcompressors.com .

CEE, 2001, “Guidelines for Energy-Efficient Commercial Unitary HVAC Systems.” Final Report, Prepared for the Consortium for Energy Efficiency, 19 January, 2001.

Custance, D., 2001, Bristol Compressors VP of Marketing, Personal Communication, February.

DOE, 2000, “TECHNICAL SUPPORT DOCUMENT: ENERGY EFFICIENCY STANDARDS FOR CONSUMER PRODUCTS: RESIDENTIAL CENTRAL AIR CONDITIONERS AND HEAT PUMPS”, October, U.S. Department of Energy. Available at: http://www.eren.doe.gov/buildings/codes_standards/reports/cac_hp_tsd/index.html .

Federal Register Document, 1999, EPA: <http://www.epa.gov/fedrgstr/EPA-IMPACT/1999/November/Day-24/i30480.htm>

U.S. Census, 2000, “Current Industrial Reports: Refrigeration, Air Conditioning, and Warm Air Heating Equipment”, Report MA333M(99)-1, Issued September.

Technology Option: Two-Speed Motors

Description of Technology: A two-speed induction motor is configured to operate at two speeds, typically full and half speed. The more-efficient design uses separate sets of two and four pole stator windings for full and half speed operation, while the less-efficient consequent pole design applies the same two-pole winding to operate at both speeds.

Description of How Technology Saves Energy: Two-speed motors reduce energy consumption by more closely matching part-load demands, reducing unnecessary throttling or cycling losses. For example, the low-speed setting enables a two-speed motor on an air-handling unit to meet sub-maximal ventilation demand with significant savings compared to a single-speed, CAV unit. Because power scales with the cube of the fan speed while flow scales proportionally to fan speed, a 50% reduction in fan speed can translate into an 87.5% reduction in power. Similarly, a two-speed motor used with a condenser fan reduces condenser fan energy consumption for partial cooling loads. A compressor coupled to a two-speed motor can better match the partial loads that dominate building cooling load profiles, reducing evaporator and condenser coil loading and cycling losses. While two-speed motors do not fall under EPACT minimum efficiency standards for integral HP motors, and thus have little direct motivation to meet higher efficiency levels, they do need to be reasonably efficient when used in a system covered by EPACT minimum efficiency standards.

Technology Technical Maturity: Current.

Systems/Equipment Impacted by Technology: All HVAC system motors.

Readily Retrofit into Existing Equipment and Buildings: Yes, for ventilation systems and pumps. Motors cannot be easily retrofitted into hermetic and semi-hermetic compressors.

Total Primary Energy Consumption by Systems/Equipment Impacted by Technology: 2.9 quads. As noted by ADL (1999), “fans and pumps in integral HP sizes typically use two-speed motors”, limiting the potential impact to around 2.3 quads¹⁰⁵.

Performance Information/Data and Source:

Summary: Two-speed motors offer much of the benefit of variable-speed drives (VSDs), achieving ~30% annual energy savings in blower, pumps, and fan applications.

ADL (1999): Two-speed motors approach the maximum efficiency of single-speed motors at full speed, but drop off a bit (~10%) at the lower speed; two-speed motors realize the

¹⁰⁵Equals the sum of: compressors (1.44 quads), non-VAV supply and return fans (0.67 quads), all pumps (0.13 quads), cooling tower and condenser fans (0.088 quads).

majority of the benefit derived from variable speed drives in compressor applications, i.e., a 30-40% SEER gain.

ADL (2000): A ~1.5HP two-speed blower motor would reduce blower energy consumption by 29% on an annual basis, in a 10-ton rooftop unit deployed in a New York City office building.

TIAX Analysis: for 15HP/5HP two-speed motor, the peak efficiency was ~86.6% versus 91-93% for single-speed, or 86-88% for single speed with ASD.

Cost Information/Data and Source:

Summary: Two-speed motors cost ~\$35 more per HP compared to single-speed induction motors (integral HP motors) and offer very attractive payback periods (<1 year) in many applications.

ADL (1999): The estimated cost of a two-speed motor used to drive a refrigerator compressor (1/8th to 1/3rd HP) is close to that of a maximum (premium) efficiency single-speed motor.

ADL (2000): In large volumes, a ~1.5HP two-speed blower motor would cost ~\$53 more than a single-speed blower, resulting in a payback of ~0.6 years.

TIAX Analysis: for 15/5HP two-speed motor, the price premium versus a 91-93% efficiency single-speed motors was ~\$32-\$39/HP for 100 unit purchases. This cost estimate does *not* include the cost of controls to select high- versus low-speed operation.

Non-Energy Benefits of Technology: By reducing cycling of AHUs and heating and cooling systems, two-speed motors decrease temperature swings and improve occupant comfort.

Notable Developers/Manufacturers of Technology: Major motor manufacturers.

Peak Demand Reduction: No. Due to their incrementally lower efficiencies relative to single-speed motors, they actually increase peak demand.

Most Promising Opportunities for Technology, Location(s) and Application(s):
Blowers and pumps.

Perceived Barriers to Market Adoption of Technology: Many vendors recommend variable speed drives over two-speed motors, reflecting a widespread view of two-speed motors as a “sunset” technology. In addition, many motor manufacturers have low interest in making two-speed motors for special applications and vendors often do not stock two-speed motors. The lower efficiency tends to cause two-speed motors to run at higher temperatures, decreasing lifetime.

Technology “Next Steps”: Education about the benefits of two-speed motors. Voluntary market promotion program for two-speed motors. Development of fractional HP two-speed motors with reasonable efficiencies.

References:

ADL, 1999, “Opportunities for Energy Savings in the Residential and Commercial Sectors with High-Efficiency Electric Motors”, Final Report for the U.S. Department of Energy, Office of Building Technology, State and Community Programs. Available at: http://www.eren.doe.gov/buildings/documents/pdfs/doemotor2_2_00.pdf .

ADL, 2000, “Energy Efficient Rooftop Air Conditioner: Continuation Application Technical Progress Statement”, Presentation on 7 November, Project #: DE-FC26-99FT40640.

Technology Option: Variable-Pitch Fans

Description of Technology: Variable-pitch fans have a pneumatic or electronic-powered mechanism that can rotate each blade of an axial fan about its spanwise axis as the fan turns and vary the effective angle of attack depending upon the conditions. Gas turbines and propeller airplanes often employ variable-pitch blades to maximize performance under a range of conditions, and variable-pitch fans have been used in industrial applications (e.g., mine venting) to achieve variable and/or reversible airflow. Variable-pitch fans also can provide precise control, for instance, in a condenser fan application to precisely control the fluid (process temperature). In HVAC applications, variable pitch fans would compete directly with variable-speed drives.

Description of How Technology Saves Energy: By actively changing the fan pitch, variable-pitch fans enable fan flow rate modulation to efficiently deliver only the needed air volume flow. In a condenser fan application, variable-pitch fans have been applied to maintain a constant water temperature in the condenser, allowing the chiller to operate smoothly without constant loading and unloading, and reduced system energy consumption.

Technology Technical Maturity: Current.

Systems/Equipment Impacted by Technology: Potentially, all fans. Mainly used to date for supply and return fans, for some larger evaporator and condenser fans (Chicago Blower, 2001).

Readily Retrofit into Existing Equipment and Buildings: Depends on geometry of installation (e.g., rooftop unit).

Total Primary Energy Consumption by Systems/Equipment Impacted by Technology: 1.3 quads (all fans).

Performance Information/Data and Source:

Summary: Variable-pitch fans realize similar performance relative to fixed-pitch fans controlled by a variable-speed drive, reducing energy consumption by ~35% relative to constant-speed fans.

Jorgenson (1990): A variable-pitch fan performs “very close” to variable-speed drive (VSD) at volume flowrates down to at least 50% of maximum.

Best Manufacturing Practices (1999): A variable-pitch condenser fan applied to a short-cycling chiller eliminated the short-cycling, realizing ~14% chiller efficiency gain (from 0.8 to 0.7 kW/ton).

ADL (1999): A VSD reduces supply and return fan energy consumption by 35% relative to a CAV fan.

Cost Information/Data and Source:

Summary: TIAX Analysis: Assuming that a variable-pitch fan performs similarly to a variable-speed drive, according to ADL (2000), a 1.5HP VSD (for VAV blower), has about a \$520 price premium over a CAV system. In comparison, the price quotes below show that a variable-pitch fan costs several thousand dollars more than a fixed pitch fan.

Chicago Blower (2001): Chicago Blower provided price quotes for a 4000cfm fan, rated for 1.5 inches of water pressure drop (for representative rooftop blower application, see Table A-8), that suggests a huge price premium of variable-pitch fans in this size range. In contrast, price quotes for an induction motor-based VAV blower of the same size suggested a price premium on the order of \$650 (ADL, 2000) relative to a fixed-speed system.

Table A-8: Axial Fan Price Quotes (from Chicago Blower, 2001)

Fan Type	Price Quote ¹⁰⁶
Variable Pitch Axial Fan	\$8,400
Adjustable Pitch ¹⁰⁷ Axial Fan	\$4,200
Fixed Pitch Axial Fan	\$1,300

Non-Energy Benefits of Technology: Higher efficiency reduces noise, reduced belt wear (continuous speed operation); precise condenser temperature control.

Notable Developers/Manufacturers of Technology: Flexxaire. Chicago Blower. Hudson Products. Howden Buffalo.

Peak Demand Reduction?: Likely no, as blowers and fans tend to operate at full speed during peak periods.

Most Promising Opportunities for Technology, Location(s) and Application(s): Very large volume flowrate applications with a wide range of ventilation requirements, e.g., very large AHU for an auditorium.

Perceived Barriers to Market Adoption of Technology: First cost. Reliability concerns about additional moving parts for variable pitch.

Technology “Next Steps”: None.

References:

ADL, 1999, “Opportunities for Energy Savings in the Residential and Commercial Sectors with High-Efficiency Electric Motors”, Final Report for the U.S. Department of Energy, Office of Building Technology, State and Community Programs, Available at: http://www.eren.doe.gov/buildings/documents/pdfs/doemotor2_2_00.pdf.

¹⁰⁶ Price includes: mounted premium motor (2HP), outlet cone, inlet bell, mounting feet.

¹⁰⁷ The pitch of the blades of an adjustable pitch fan can be varied, albeit not during operation. Consequently, an adjustable pitch fan cannot realize the same variable flow operations and savings as a variable-pitch fan.

ADL, 2000, “Energy Efficient Rooftop Air Conditioner: Continuation Application Technical Progress Statement”, Presentation on 7 November, Project #: DE-FC26-99FT40640.

Best Manufacturing Processes, 1999, “Polaroid Corporation – Chiller Performance”. Available at: http://www.bmpcoe.org/bestpractices/internal/polar/polar_45.html .

Chicago Blower, 2001, Price quote to Arthur D. Little, Inc.

Jorgensen, R., 1990, “Fans and Blowers”, appearing in **Handbook of HVAC Design**, McGraw-Hill: New York, New York.

Technology Option: Variable-Speed Drives

Description of Technology: Variable speed drives (VSDs) enable the motors driving fans, compressors and pumps to run at a range of speeds to meet the demand. Variable-speed drives use pulse-width modulation (PWM) to vary the frequency of the electricity delivered to standard induction motors to control their rate of rotation. In switched reluctance motors (SRMs), solid-state electronics and software modulate and control the rate of stator windings energizing to achieve variable speed operation. In the case of electronically commutated permanent magnet motors (ECPMs), the VSD electronics vary the rate at which the stator windings are energized (in phase with the rotation of the motor rotor) to vary the rotational rate of the motor.

Description of How Technology Saves Energy: By operating at the speed required by the application, variable-speed drives allow pumps, fans, and other equipment to efficiently meet partial loads, avoiding cycling losses caused by on/off operation and throttling losses generated by flow throttling (e.g., with dampers or valves). Pumps and fans typically follow a speed-cubed power law, so that modest reduction in speed and flow translate into significant reduction in power (e.g., at ½ of design speed and flow, the power input equals 1/8th the design power input). Variable-speed operation of large centrifugal compressors provides more efficient part-load capacity modulation than inlet guide vanes, and extends the operating range to lower capacity levels before hot gas bypass is required to prevent surging.

Technology Technical Maturity: Current.

Systems/Equipment Impacted by Technology: All motors in HVAC, particularly unitary blowers. VAV blowers are not common in most 10-ton rooftop units; typically, the smallest units offered with VAV are in the 20 to 30-ton range.

Readily Retrofit into Existing Equipment and Buildings: Yes.

Total Primary Energy Consumption by Systems/Equipment Impacted by Technology: 2.8 quads (all HVAC motors, including compressors, except VAV supply and return fans).

Performance Information/Data and Source:

Summary: In blowers, can reduce unitary AC energy consumption by about 1/3rd, with typical payback periods in the 3-year range for rooftop blower and AHU applications.

ADL (1999a): About 50% increase in compressor SEER from VSDs; Estimated ~0.28 Quads of savings in HVAC from using VSD; Table A-9 shows savings break-down, with updated quad values from ADL (1999b).

Table A-9: Variable Speed Drive Technical Energy Savings Potential

VSD Application	Application Energy Savings, % (from ADL, 1999a)	Quads Consumed (from ADL, 1999b, ADL, 2001)	Energy Savings Potential (quads)	Simple Payback Period
Large Unitary AHU and Central AHU (VSD + Supply and Return Fans, Unitary >20 tons, CAV units)	40%	0.43	0.17	~ 2.5 years (relative to inlet vanes)
Medium Unitary (VSD + Supply and Return Fans, Unitary <20 tons)	32%	0.21	0.07	~ 2.5 years (relative to inlet vanes)
VSD+ Hot/Chilled Water Distribution Pump	50%	0.10	0.05	~3 years
VSD+ Cooling Water Pump	40%	0.027	0.011	~4Years
VSD + Compressors (considered only 5 to 10-ton Unitary, heat pumps)	33% (50% SEER Gain)	0.39	0.13	Likely >10 years
Large Centrifugal Compressors	10 to 15%	0.19	0.02	Unknown; in market (Carrier)

Note: Two-Speed compressors/motors realize about 75% of the savings of VSD systems (ADL, 1999a), with much shorter pay-back periods for compressor applications (DOE, 2000).

TIAX Analysis: ASDs impose about a 5% efficiency decrease for motors operating at full load (from drive losses; studied for 15HP motors, likely somewhat less for larger drives).

L. Campoy (SoCalEdison): 25% energy savings for centrifugal chiller retrofit with VSD in office building, 28% for 600-ton unit in hotel.

Trane (2001): ASD/inlet guide vanes, in combination with condenser relief (i.e., allowing the condenser water temperature to decrease as load decreases), leads to significant energy savings at loads below ~90% of full load relative to a single-speed drive with only inlet guide vanes (however, peak load increases slightly due to efficiency hit from ASD controls); Trane claims ~20-25% NPLV improvement from ASD; in IPLV terms ~0.49 (all kW/ton; from plot at: <http://www.trane.com/commercial/equipment/afd.asp>) a ~28% savings.

CEE(2001): study of 10 medium-to-large commercial unitary blower VAV retrofits showed 3-12 year payback periods.

Bahnfleth and Peyer (2001): For a 500-ton chiller plant systems, they estimate that an all-variable system has ~2 year simple payback relative a constant flow system for a single-chiller system, or ~3-year simple payback for a two-chiller system¹⁰⁸.

¹⁰⁸ Electricity cost \$0.035/kW-h, with a \$15/kW demand charge; 5-storey office building located in central NY state, 28k ft²/floor; curve fits for component performance.

Cost Information/Data and Source:

Summary: Approximate price premium for ASD is about \$100/HP in the 15HP range (larger Rooftop blower, AHU); more at smaller motor sizes, less at larger motor sizes. VSD costs should continue to decrease due to lower costs for power semiconductors and electronic components as controls migrate to chip-level.

ADL (1999a): Cost ranges from \$35-71 for 9-304W ECPM motors. Most commercial HVAC options have paybacks of less than 3 years, while replacements are closer to 5 years. PWM are mass-produced in Japan in the ~1.5HP size for mini-split heat pumps (compressors), with an estimated OEM price of \$100-125/HP.

TIAX Analysis: A 15HP motor with VSD used for a HVAC central blower application has a ~\$1,700 price premium (\$115/HP over a \$39-\$46/HP for 91%/93% efficient motors; volume: 100 units). If one uses a VSD that controls the motor up to 3HP or 5HP (instead of 15HP), the VSD cost decreases to \$97/\$133 per HP, or a \$51/\$87 per HP premium over the 93% motor.

ADL (2000): for ~1.5HP VSD (for VAV), inverter cost ~\$260 or ~\$520 price premium; for SRM VSD, inverter/controls cost premium ~\$550, or ~\$1100 price premium.

Nadel et al. (1998): Switch reluctance motors have an incremental cost of about a \$2,000 for a 20 hp installation, (\$125 each for a ½ hp package) which is 50% more than an induction motor with variable speed control. Japan carries manufacturing costs at about \$25/hp. ECPMs cost \$50/hp more than an induction motor with variable speed drive.

Cler et al. (1997, page 295, from): ASD for chillers cost \$40-100/HP.

Cler et al. (1997, pp. 88-90): “typical air flow requirements are only about 60% of full C-V flow.” A survey of 10 large VAV retrofits showed cost of between \$0.67-7.10/ft² (average ~\$3.40/ft²), translating into 0.29-12.2 year simple payback periods (w/o utility rebates); poor VAV design, notably on the controls end (e.g., setting minimum flow too high such that system effectively operates as CAV), can greatly decrease VAV savings.

Non-Energy Benefits of Technology: Increased user comfort due to reduction of over-heating and –cooling via modulated delivery of hot and cool air, as well as from improved humidity control.

Notable Developers/Manufacturers of Technology: Numerous (Reliance Corporation; Emerson; Siemens; Danfoss Graham; Invensys; ABB; A.O. Smith/Baldor; GE).

Peak Demand Reduction: No. The VSD electronics actually lead to a slight performance degradation at peak load; TIAX analysis shows ~5% hit, assuming operation at full speed.

The partial VSD concept, i.e., using a VSD only at loads smaller than full load, e.g., <50%, eliminates this drawback.

Most Promising Opportunities for Technology, Location(s) and Application(s):

Unitary blowers; air handlers; compressors with wide ranges of loads; buildings and spaces with very large variations in occupancy (e.g., food service). Fume hoods in laboratories are particularly promising, due to highly intermittent operation and very large difference between operational and base ventilation rates by 50-90% relative to bypass hoods (Wilkinson, 2001).

Perceived Barriers to Market Adoption of Technology: First cost, in part due to relatively small production volumes. Complexity of maintaining and operating motors and controls.

Technology “Next Steps”: Development to reduce the cost of drives. Re-designing the technology to be quieter and simpler. Note that many electric utility demand-side management (DSM) programs offer rebates for VSDs for blowers.

References:

ADL, 1999a, “Opportunities for Energy Savings in the Residential and Commercial Sectors with High-Efficiency Electric Motors”, Final Report for the U.S. Department of Energy, Office of Building Technology, State and Community Programs, December. Available at: http://www.eren.doe.gov/buildings/documents/pdfs/doemotor2_2_00.pdf .

ADL, 1999b, “Energy Consumption Characteristics of Commercial Building HVAC Systems Volume II: Thermal Distribution, Auxiliary Equipment, and Ventilation”, Final Report for the U.S. Department of Energy, Office of Building Technology, State and Community Programs, October. Available at: <http://www.eren.doe.gov/buildings/documents/pdfs/comhvac.pdf> .

ADL, 2000, “Energy Efficient Rooftop Air Conditioner: Continuation Application Technical Progress Statement”, Presentation on 7 November, Project #: DE-FC26-99FT40640.

ADL, 2001, “Energy Consumption Characteristics of Commercial Building HVAC Systems Volume I: Chillers, Refrigerant Compressors, and Heating Systems”, Final Report for the U.S. Department of Energy, Office of Building Technology, State and Community Programs. Available at: <http://www.eren.doe.gov/buildings/documents/pdfs/hvacvolume1finalreport.pdf> .

Bahnfleth, W.P. and Peyer, E., 2001, “Comparative Analysis of Variable and Constant Primary-Flow Chilled-Water-Plant Performance”, *HPAC Engineering*, April, pp. 41-50.

Campoy, L., 2000, “So. Cal. Edison Emerging Technologies.” Downloaded from: <http://www.ca-etcc.com/Database/ETdatabase.pdf> .

CEE, 2001, "Guidelines for Energy-Efficient Commercial Unitary HVAC Systems", Final Report, Prepared for the Consortium for Energy Efficiency, 19 January.

Cler, G. et al., 1997, **Commercial Space Cooling and Air Handling: Technology Atlas**. E Source, Inc.

DOE, 2000, "TECHNICAL SUPPORT DOCUMENT: ENERGY EFFICIENCY STANDARDS FOR CONSUMER PRODUCTS: RESIDENTIAL CENTRAL AIR CONDITIONERS AND HEAT PUMPS." October, U.S. Department of Energy.

Fryer, L. "Electric Chiller Buyer's Guide: Water-Cooled Centrifugal and Rotary Screw Chillers." E-Source Tech Update, TU-97-7.

Nadel, S., Rainer, L., Shepard, M., Suozzo, M., and Thorne, J, 1998, "Emerging Energy-Saving Technologies and Practices for the Building Sector", American Council for an Energy-Efficient Economy (ACEEE) Publication, December.

Wilkinson, R., 2001, "EPICenter Building is Green Focal Point in Montana", *Energy User News*, January, pp. 27-28.

Technology Option: Zeotropic Refrigerants

Description of Technology: A zeotropic refrigerant is a mixture of two or more immiscible refrigerants. Unlike other refrigerants, zeotropic refrigerants do not maintain a constant temperature during a phase change at constant pressure (called temperature “glide”), instead exhibiting a changing temperature profile that reflects the fact that different components of the refrigerant have different phase change characteristics (temperatures and pressures). This unique behavior of zeotropic refrigerants occurs in the condenser and evaporator of a vapor-compression refrigeration cycle, and distinguishes them from other refrigerants. Zeotropic refrigerants can be custom blended for optimum air-conditioner performance under specific operating conditions (e.g., fractionation technology in development to continuously vary the blend under changing operating conditions to match load and improve part-load and seasonal performance).

Description of How Technology Saves Energy: Theoretically, the most efficient air-conditioner would have an infinitely large condenser and evaporator and the refrigerant temperature at every point in the evaporator and condenser would exactly match the temperature of the air in each. Standard refrigerants (HCFC-22 for example) have a constant liquid-vapor phase temperature while the airside temperature changes, so the refrigerant temperature can never match the air at every point even for an infinitely large heat exchanger (only at a single point, called the “pinch point”). The temperature “glide” of zeotropic refrigerants can be utilized in counter-flow heat exchangers to more closely match the temperature of the air at every point, thus minimizing the required temperature gradient and maximizing the efficiency of the air-conditioning cycle. Realistically, however, the actual energy savings of an air-conditioning system using a zeotropic refrigerant is restricted by the physical size of the evaporator and condenser as well as the refrigerant’s heat transfer and thermodynamic properties (which are typically inferior to HCFC-22 and other traditional refrigerants). Emerging fractionation technology that adjusts the zeotropic refrigerant mixture in an air-conditioner under changing operating conditions is a promising energy-saving technology since it enables manipulation of refrigerant properties to better match operating conditions.

Technology Technical Maturity: Current. At least one manufacturer (York) sell chillers using the zeotropic refrigerant R-407C and exploit its glide properties. Some compressor manufacturers, including Copeland, have recently adopted the zeotrope R-410A for use in commercial air-conditioning applications. In practice, R-410A is only nominally a zeotrope because it exhibits very little glide and minimal fractionation at typical operating temperatures and pressures and no manufacturer has developed systems that exploit its very limited zeotropic properties.

Systems/Equipment Impacted by Technology: All vapor-compression cycles.

Readily Retrofit into Existing Equipment and Buildings: No. (For example, to save energy with zeotropic refrigerants versus HCFC-22 requires significantly larger condenser and evaporator units than typically used.)

Total Primary Energy Consumption by Systems/Equipment Impacted by Technology:
1.4 Quads

Performance Information/Data and Source:

Summary: Air conditioners using zeotropic refrigerants do not tend to outperform those using HCFC-22, despite their ability for “glide matching,” because they typically have poorer heat transfer and thermodynamic properties. Technology that continuously adjusts the zeotropic mixture, however, may have promising energy-saving potential since it can optimize air-conditioner performance under a wide range of operating conditions.

Payne et al. (1999): Experimental testing of a heat-pump system in cooling mode revealed a 6% decrease in overall COP using zeotrope 32/152a (with “glide matching”) versus HCFC-22.

Sands et al. (1997): Zeotrope R-407C (R32/125/134a) had the same COP in a heat pump (heating and cooling modes) as did HCFC-22, while R-410A (R32/125) gave a ~5% improvement in COP.

Kusaka et al. (2000): Matsushita’s R-407C composition control (fractionation) system demonstrated a ~25% increase in COP at ~80% of full capacity by creating a large swing in system constituents.

Cost Information/Data and Source:

Summary: Zeotropic refrigerants are more expensive (~\$9/lb versus ~\$2/lb for HCFC-22 according to a price quote from United Refrigeration), but the overall air-conditioning equipment costs are comparable. Replacing the refrigerant of an existing system is uncommon since the cost of a new system is on the order of only 40% more than the retrofit (because the lubricants must be purged and replaced for the retrofit). Fractionation equipment costs are not known (still in development), but are expected to be significant.

Non-Energy Benefits of Technology: Zeotropic blends (primarily consisting of HFC refrigerants) are specifically created to perform like CFC and HCFC refrigerants (specifically HCFC-22), but do not deplete the ozone layers and have a lower GWP.

Notable Developers/Manufacturers of Technology: NIST, ORNL, Matsushita (refrigerant composition control fractionation system).

Peak Demand Reduction?: Depends (for fractionation equipment – depends upon how the original refrigerant is formulated; for a conventional cycle - theoretically if the zeotropic

blend matches the temperature glide and the overall peak efficiency is increased, but considering the size limitations on condensers and evaporators the answer is more likely NO).

Most Promising Opportunities for Technology, Location(s) and Application(s):

Zeotropic refrigerant research has focused upon unitary air-conditioning equipment because they can easily replace HCFC-22 (traditionally used in unitary equipment). Refrigerant composition control systems will likely generate the greatest energy savings in locations and applications with a wide range of operating conditions.

Perceived Barriers to Market Adoption of Technology: Energy-saving benefits of zeotropic refrigerants are marginal at best, while costs are increased (particularly for refrigerant composition control systems, which also increase system complexity). Contractors are less familiar with zeotropic refrigerants as they are just coming into the market. Fractionation systems would likely create significant cost increases.

Technology “Next Steps”: Assessment of potential savings of composition control equipment/system; development of cost-effective refrigerant composition control equipment/systems.

References:

Kusaka, M., Nakatani, K., and Takatani, T., 2000, “The Development of the Energy-Saving Technology by the Composition Control of R-407C”, *Eighth International Refrigeration Conference at Purdue University*, West Lafayette, IN, USA, July 25-28, 2000.

Payne, Domanski, and Muller, 2000, “A Study of a Water-to-Water Heat Pump Using Hydrocarbon and Hydrofluorocarbon Zeotropic Mixtures”, NIST.

Sand, J.R., Fischer, S.K., and Baxter, V.D., 1997, “Energy and Global Warming Impacts of HFC Refrigerants and Emerging Technologies”, **Alternative Fluorocarbons Environmental Acceptability Study**, U.S. Department of Energy.

APPENDIX B: THE ORIGINAL LIST OF 175 OPTIONS

Tables B-1 and B-2 list the original options considered for study, sorted by option type. Counting of the options listed yields a total of 164 options; several options originally considered were deleted because they involved renewable energy and for other reasons. Over the course of the project, several options were combined into a single options when studied further (e.g., many of the control options were combined under Adaptive/Fuzzy Logic, System/Component Diagnostics).

Table B-1: Original List of Component and Equipment Options

Components (49)	Equipment (44)
Advanced Desiccant Materials for Active Desiccant Dehumidification	Active Desiccant (Gas-Fired)
Advanced Noise control	Advanced Compressors
Aerosol Duct Sealants	Alternative Air Treatment (e.g., UV light) to Enable Reduced Outdoor Air
Airfoil-Blade Centrifugal Fan	Alternative Cooling Cycles: Lorentz, Malone, Stirling, etc.
Backward-Curved Blade Centrifugal Fan	Ambient Subcoolers
Better Jacketing/Insulation of Heater/Chiller Units	Chemical Exothermic Heat/Cool Generation/Distribution
Better Pipe Insulation	Chiller Water Economizer
Coil and Tube Heat Exchanger	Condensing Gas Boilers/Furnaces
Copper Rotor Motor	Condensing Oil Boilers/Furnaces
Direct-Contact Heat Exchanger	Cool Storage Roof
Disk Permanent Magnet Motors	Deep Heat Transfer Coil
Double-Salient Permanent Magnet Motors	Dual Fuel Heat Pump
Two-Speed Motors	Dual Source Heat Pump
Electrohydrodynamic Heat Transfer	Dual-Compressor Chillers
Electronic Expansion valves	Economizer
Brushless DC Motors	Electrostatic Filter
Enhanced Swirl/Mixing in furnaces	Engine-Driven Heat Pump
Evacuated Motors	Enthalpy/Heat Wheel
Heat Pipes	Water-Cooled Condensers for Unitary Equipment
High-Efficiency Fan Blades: Optimized Blade for Each Application	Evaporative Precooling (Make-up air)
High-Temperature Superconducting Motors	Floating-Head Pressure in Large Direct-Expansion Vapor-Compression Systems
Interior Duct Insulation	Ground-Coupled Heat Pumps
Improved Duct Sealing	High-Efficiency Pumps
Improved Efficiency Oil Burner	Hybrid Chillers
Indirect-Direct Evaporative Coolers	In-Room Zonal Radiant Heating/Cooling
Inlet Guide Vanes (pumps and fans)	Kitchen Ventilation Heat Recovery
Larger Pipes	Liquid Desiccant Air Conditioner
Low-Pressure Refrigerant Cycles	Lower-dP Diffusers
Microchannel Heat Exchanger	Lower-dP Terminal Boxes
Natural Refrigerants (CO ₂ , H ₂ O, NH ₃)	Low-Temperature Absorption Chillers
Optimize Cooling Tower Air Flow	Magnetic Cooling Cycles
Peltier Effect Heat Transfer	Mechanical Subcooler
Polymer/Surfactant Additives for Liquid Friction Reduction	Membrane Humidity Control
Premium Lubricants	Modulating Boilers/Furnace
Refrigerant Additives to Enhance Heat Transfer	Phase Change Ceiling/Insulation
Refrigerant Management System	Rotary Screw Compressors
Refrigerant Pump to Reject Compressor Heat Directly	Runaround Recovery Coils

to Condenser	
Shading Condenser Coils	Smaller Centrifugal Compressors
Smooth Duct Section Connections	“Swamp” Cooler
Smooth Duct Transitions	Thermoacoustic Cooling
Spray Evaporator Heat Exchanger	Triple Effect Absorption Chillers
Switched Reluctance Motors	Twin-Single Compressors
Unconventional Heat Pipes	Variable-Speed Drives
Unsteady Flow (pulsed, acoustically-forced) to Enhance Heat Transfer	“Zero Degree” Heat Pump (Heat Pump for Cold Climates)
Use Larger Fan Blades	
Use Low-Friction Pipes	
Variable Pitch Fans	
Written Pole Motors	
Zeotropic Refrigerants	

Table B-2: Original List of System and Controls/Maintenance/Operations Options

System (32)	Controls / Maintenance / Operations (39)
All-Water versus All-Air Thermal Distribution Systems	Accurate Steam Meters (to enable sub-metering)
Apply Energy Models to Properly Size HVAC Equipment	Active Control of Desiccant Regeneration
Controlled Mechanical Ventilation	Adaptive/Fuzzy Logic HVAC Control
Demand Control Ventilation	Building Automation Systems
Dedicated Outdoor Air Systems	Complete Commissioning
Ductless Split Systems	DDC Optimized Chiller Control
Eliminate Balance Valves in Chilled Water Loops	DDC HVAC Control (versus Pneumatic Control)
Eliminate Design Flaws	DDC to Optimize Set Points
Eliminate Series Fan Boxes	DDC to Reduce Superheat/Subcooling
Evaporative Roof Cooling	DDC Finite State Machine Control
High Heat Capacity Liquid-Vapor Chilled Water Loop/Slurries	Duct Cleaning to Reduce Pressure Drop
Hydrocarbon Refrigerants	Electrolytic Cooling Water Treatment
Larger Duct Cross Sections	Electron Beam Cooling Water Treatment
Low-Temperature Chilled Water / Low-Temperature Air	Energy Recovery Controller (~Building Energy Management System for Energy Recovery)
Mass Customization of HVAC Equipment	Fan Overrun for On/Off Units
Mini-Duct System	Incorporating Weather Predictions into Building Automation System Operations
Mixed-Mode Conditioning (i.e., including natural ventilation)	Increase Hydronic Cooling Temperature Difference
Multi-Intake Air Economizer	Maintain Intended Operation/Calibrate Sensors
Multiple Boiler Units	Maintain Proper Refrigerant Charge
Microenvironments (Task-ambient conditioning)	Microprocessor-Based Motor Control
Optimize Condenser Water Pump Size	Microprocessor-Controlled Boilers
Radiant Ceiling Cooling/Heating (including Chilled Beam)	Microwave Cooling Water Treatment
Reduced/Zero Maintenance Component Design	More Frequent Filter Replacement / Filter Diagnostics
Thermal Energy Storage	Multiple Chillers/Cooling Towers
Two-Way Valves (Replace 3-way valves) in Chillers	Night Pre-Cooling of Buildings
Under-floor/Displacement Ventillation	Ozone Condenser Water Treatment
Use IAQ Method to Reduce OA	Personal Thermostats (e.g. Ring Thermostat)
Use Separate Units for Unique Spaces	Proper Alignment of Fans-Ducting
Variable Refrigerant Volume/Flow	Proper Thermostat Placement
Venting Outlets away from Walls	Proper Water Treatment/Additives
Water-Loop Heat Pump System (California Loop)	Regular Maintenance
Zonal Ventilation/Control	Retro-commissioning
	Solenoid-Induced Molecular Agitation Cooling Water Treatment

	Submetering Loads
	System/Component Performance Diagnostics/Repair/Maintenance
	Train More HVAC Professionals
	Trim Pump Impellers
	UV Radiation Cooling Water Treatment
	VAV: Plenum Pressure Control for Modulation